



宇 | 星 | 模 | 王

**CREATIVE IDEA**  
百变创意

航空发动机  
NO.AIRCRAFT ENGINE

10141

2256+ Pcs/Pza

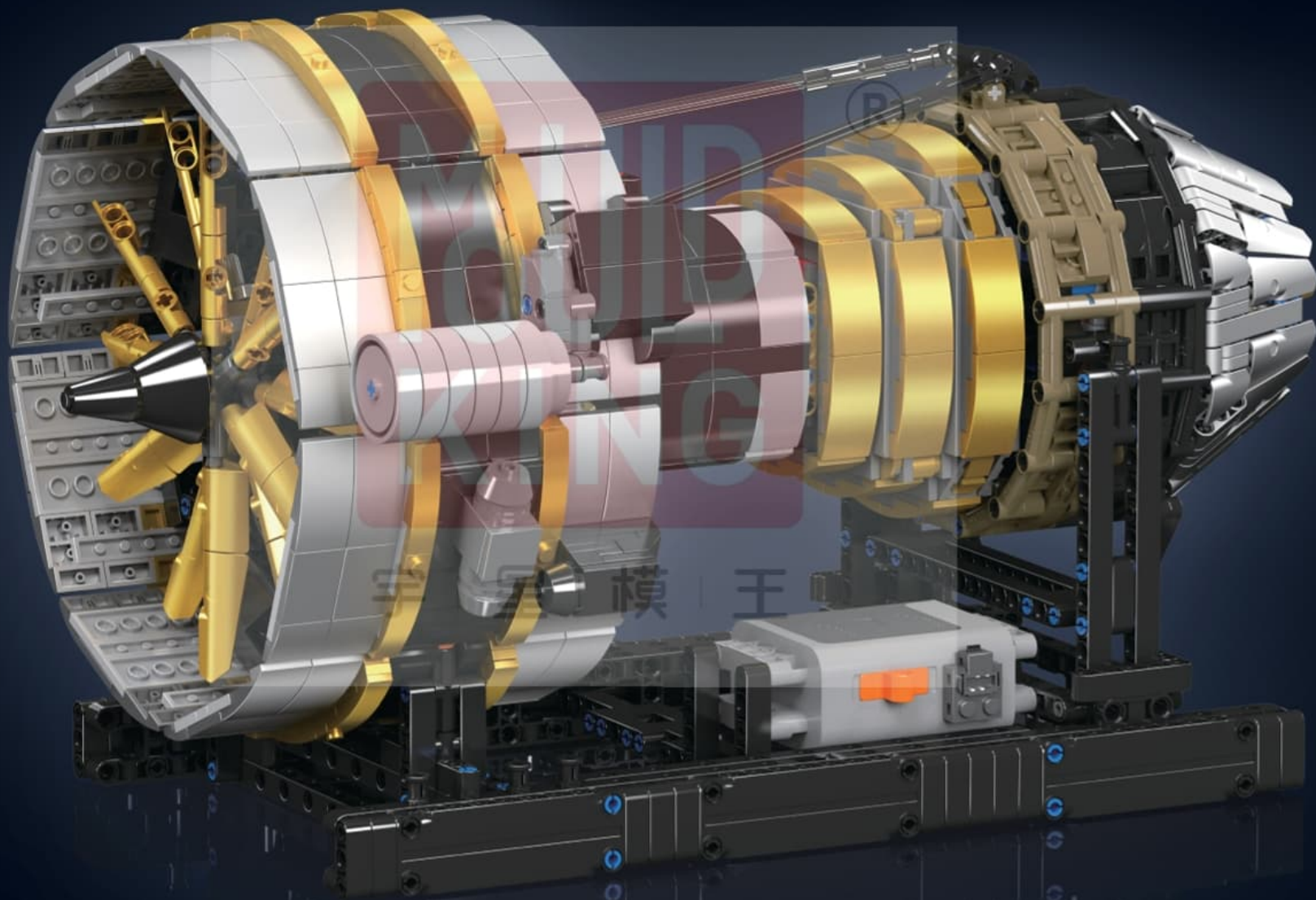



QR Code APP (APP二维码)  
QR-Code-App  
Application Code QR  
App Codice QR  
Aplicación de Código QR  
QRコードアプリ

Need the apple version 9.0 and above, the android version 5.0 and above.  
Erfordert iOS Version 9.0 oder höher, Android Version 5.0 oder höher.  
Nécessite la version 9.0 ou supérieure pour Apple, et la version 5.0 ou supérieure pour Android.  
Richiede la versione 9.0 o superiore per Apple, e la versione 5.0 o superiore per Android.  
Requiere versión 9.0 o superior para Apple, y versión 5.0 o superior para Android.  
Appleはバージョン9.0以上、Androidはバージョン5.0以上が必要です。

\*This APP supports most of the mainstream Android models on the market, but due to the large number of Android models, different models of systems and hardware reasons, there may be some models do not supported,specific according to the actual test!

\*Diese App unterstützt die meisten gängigen Android-Modelle auf dem Markt. Aufgrund der großen Anzahl von Android-Modellen und unterschiedlicher System- und Hardwarebedingungen kann es jedoch sein, dass einige Modelle nicht unterstützt werden. Die Kompatibilität hängt vom tatsächlichen Test ab!

\*Cette application prend en charge la plupart des modèles Android populaires sur le marché, mais en raison du grand nombre de modèles Android, de différents systèmes de modèles et de raisons matérielles, certains modèles peuvent ne pas être pris en charge, selon le test réel !

\*Questa app supporta la maggior parte dei modelli Android mainstream sul mercato, ma a causa del grande numero di modelli Android, diversi modelli di sistemi e motivi hardware, potrebbero esserci alcuni modelli che non sono supportati, specifici secondo il test effettivo!

\*Esta aplicación es compatible con la mayoría de los modelos Android principales en el mercado, pero debido al gran número de modelos de Android, diferentes modelos de sistemas y razones de hardware, puede haber algunos modelos que no son compatibles, específicos según la prueba real!

\*このアプリは市場に出ている主流のAndroidモデルのほとんどをサポートしていますが、Androidモデルの数が非常に多く、システムやハードウェアの違いにより、サポートされないモデルが存在する可能性があります。実際のテストによります！



广东宇星科技  
Mould King



产品资讯  
Product Information  
Produktinformation  
Information sur le produit  
Informazioni sul prodotto  
Información del producto  
製品情報

宇 | 星 ? 模 | 王

售后服务  
After-sales Service  
Kundendienst nach dem Kauf  
Service après-vente  
Servizio post-vendita  
Servicio postventa  
アフターサービス



积木补件  
Brick Replacement Service  
Ziegelstein-Ersatzdienst  
Service de remplacement de briques  
Servizio di sostituzione dei mattoncini  
Servicio de reemplazo de ladrillos  
ブロック交換サービス



# OPEN

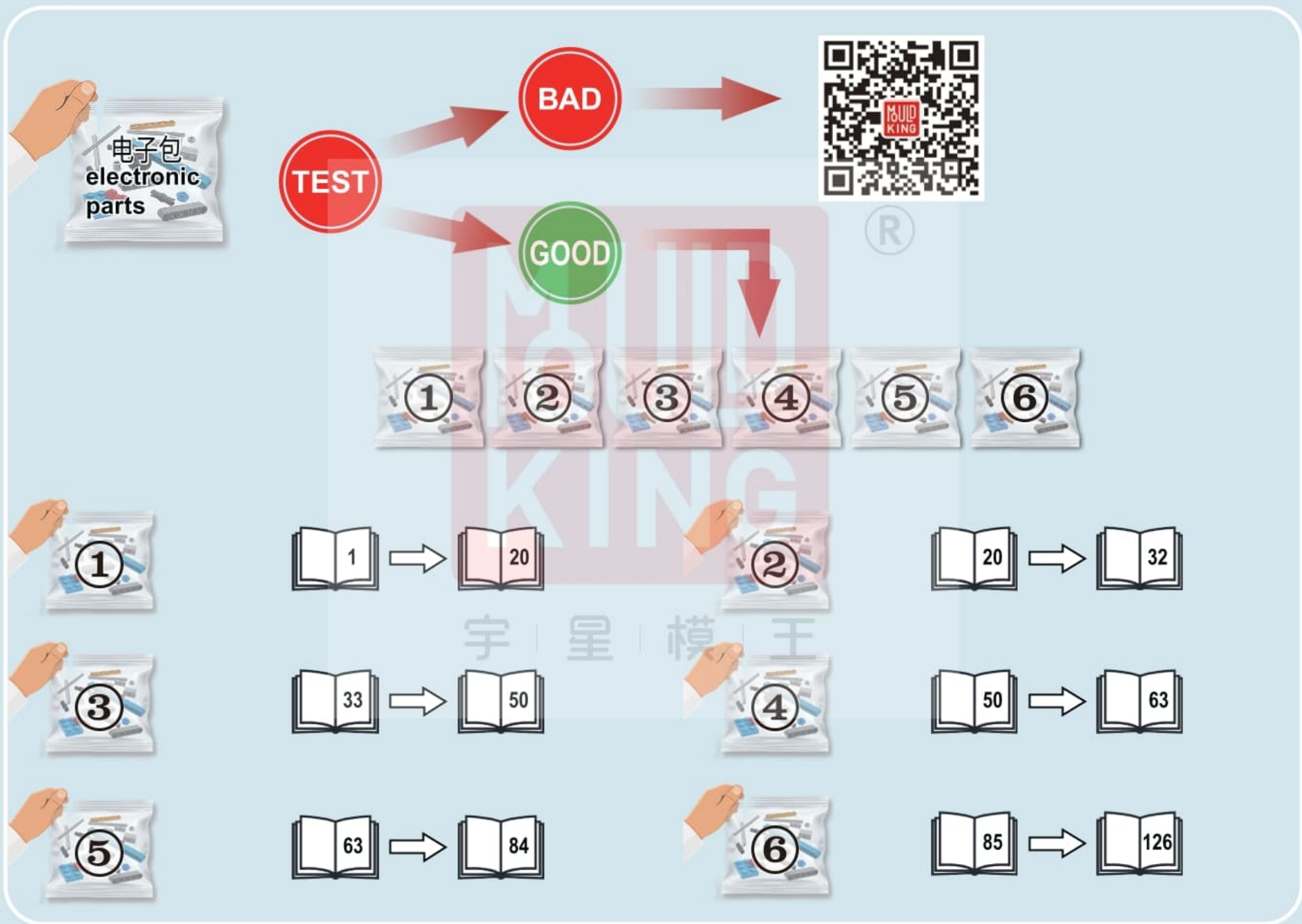

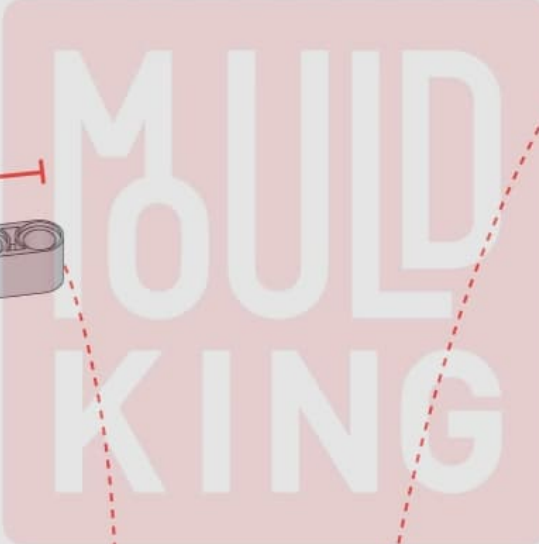

宇 | 星 | 模 | 王

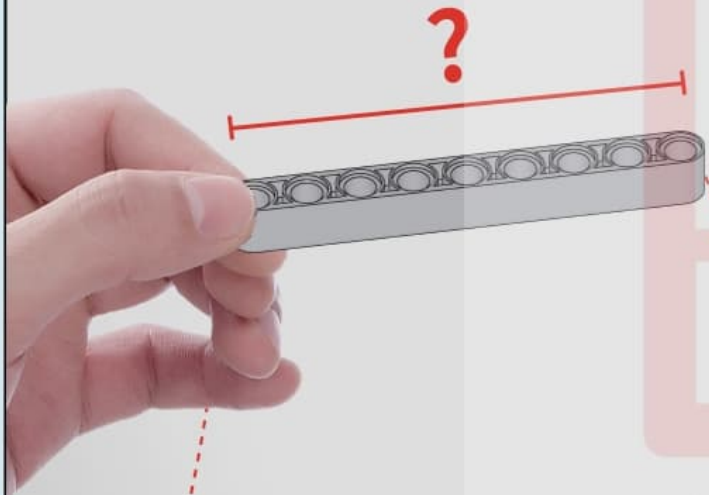



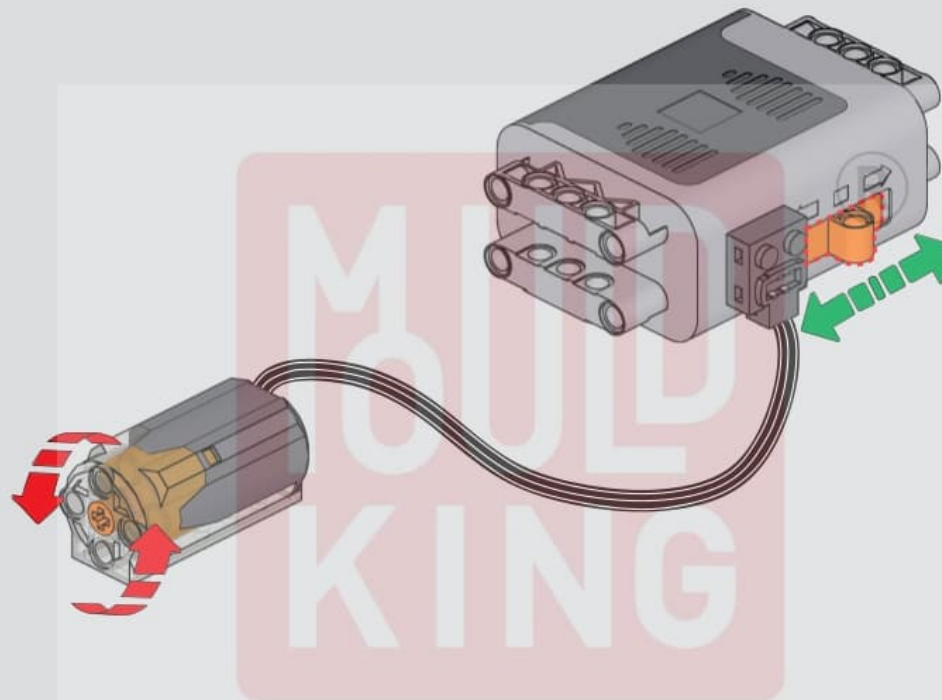

拼装前需测试所有电子件功能是否正常，此电池盒需自行装配电池。

Test all electronic components for functionality before assembly; the battery box needs to be assembled by yourself.

Testen Sie alle elektronischen Komponenten auf ihre Funktionalität, bevor Sie sie zusammenbauen; das Batteriefach muss selbst zusammengebaut werden.

Testez toutes les composantes électroniques pour leur fonctionnalité avant l'assemblage; le boîtier de batterie doit être assemblé par vous-même.

Testa tutte le componenti elettroniche per la loro funzionalità prima dell'assemblaggio; la scatola delle batterie deve essere assemblata da te.

Pruebe todas las componentes electrónicas para su funcionalidad antes del montaje; la caja de baterías necesita ser ensamblada por usted mismo.

組み立て前にすべての電子部品の機能をテストし、このバッテリーボックスは自分で組み立てる必要があります。

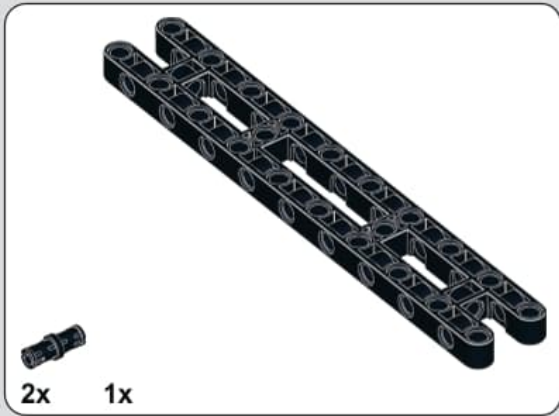
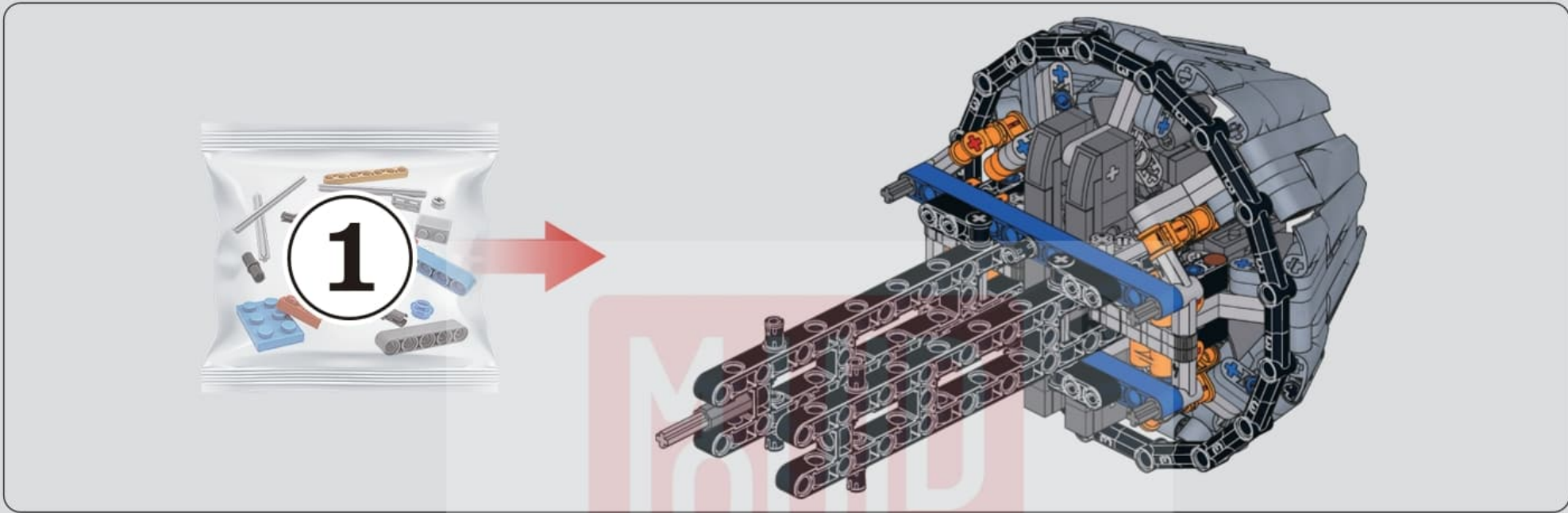

1

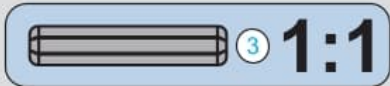

2 宇 | 星 | 模 | 王

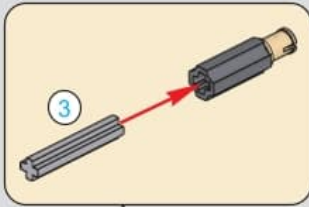
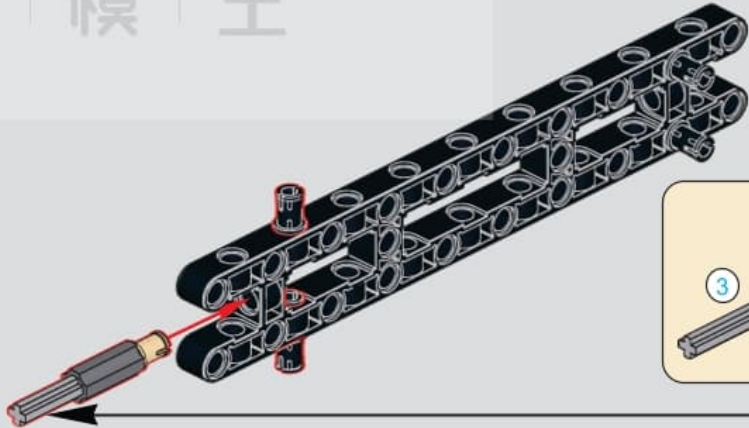
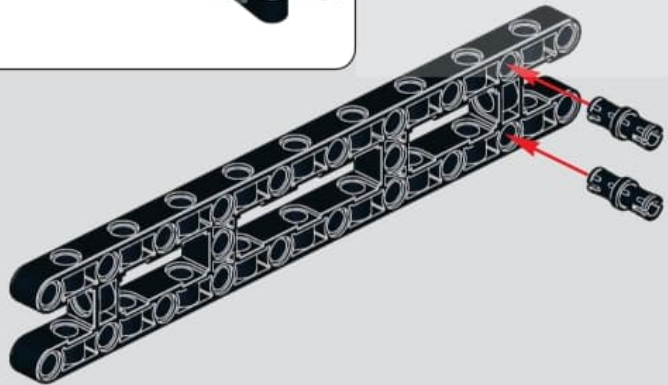



3

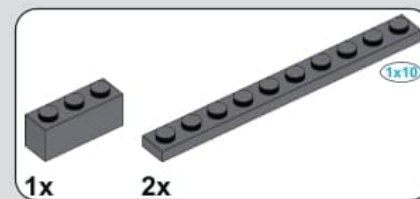
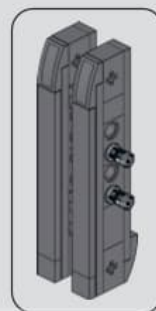
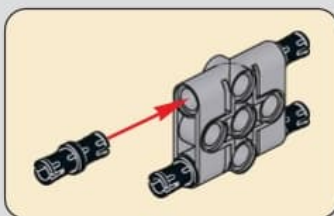

4

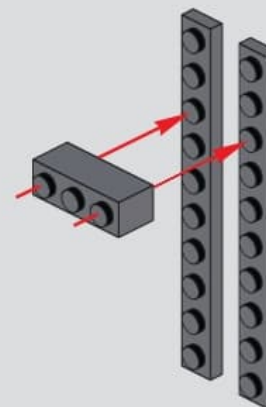
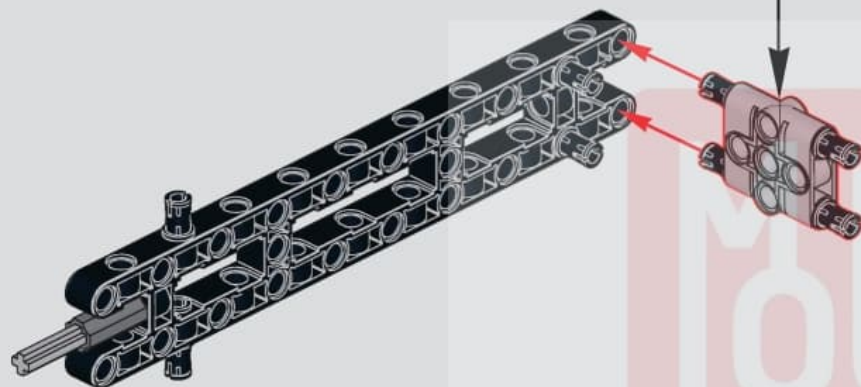

5

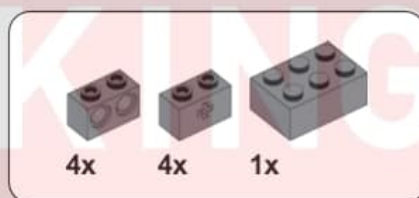
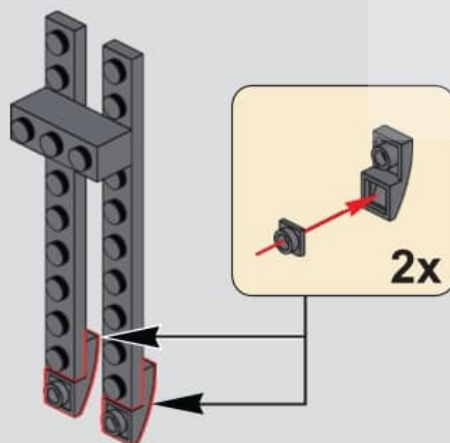

6



7





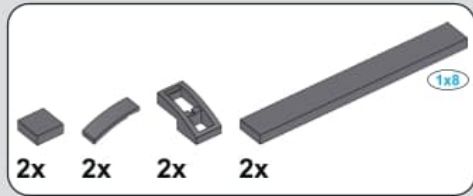

8

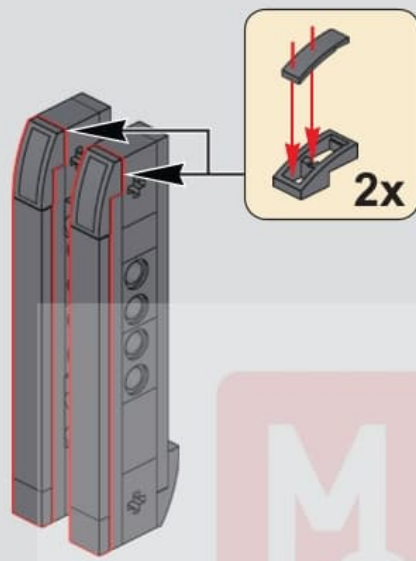

9

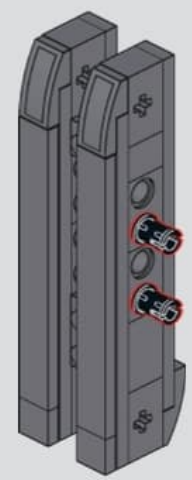

10

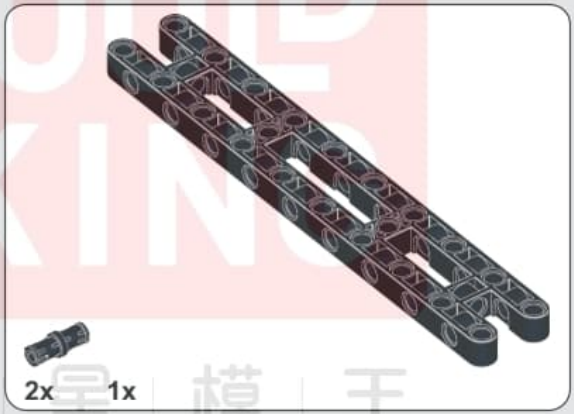
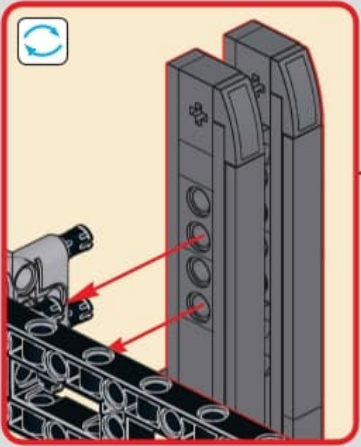

11

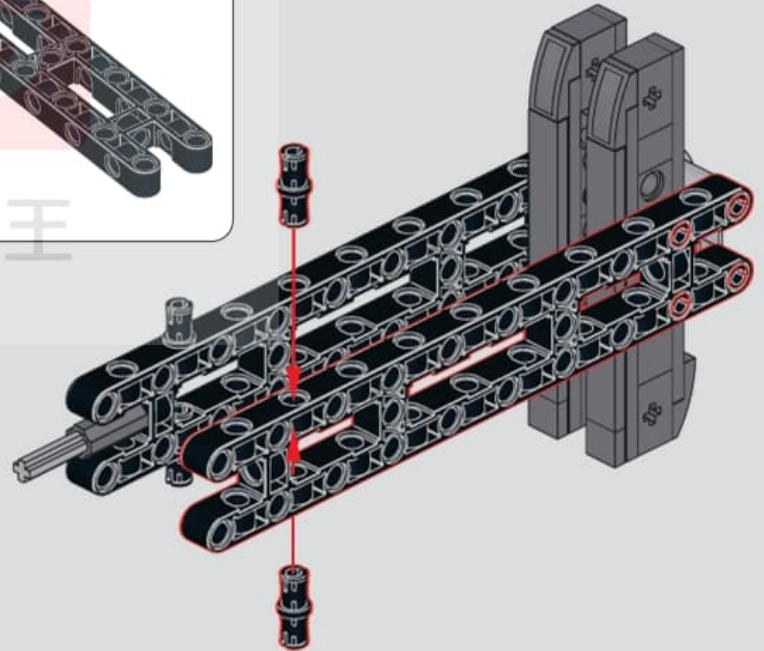
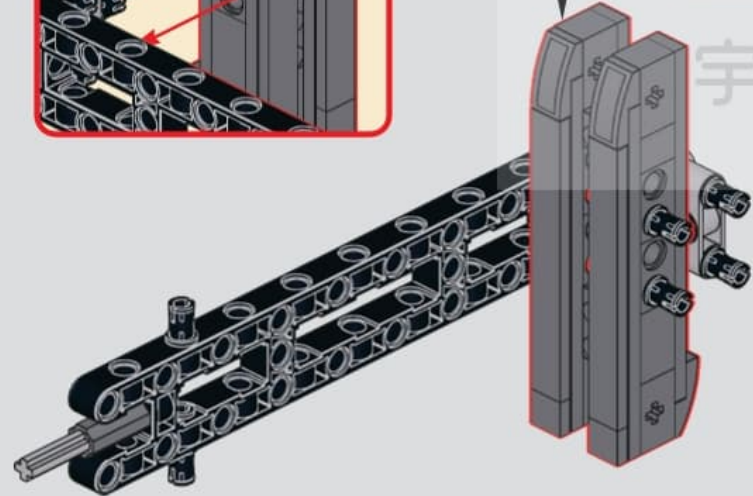

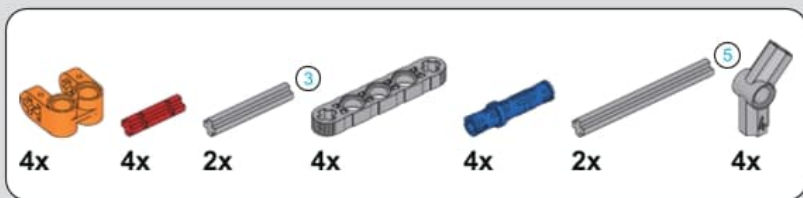

12

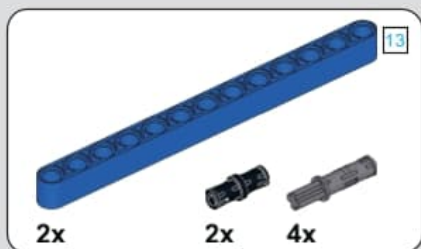
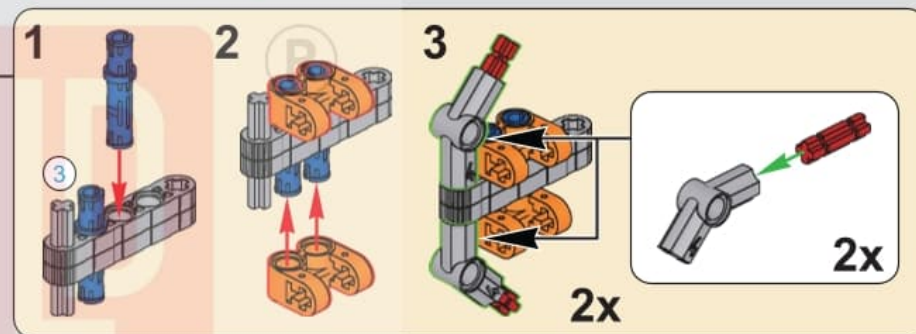
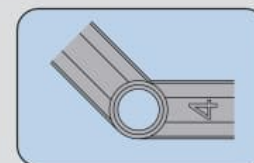
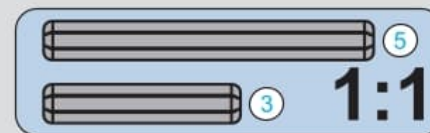
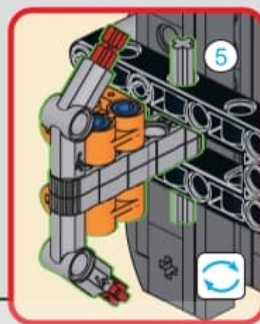
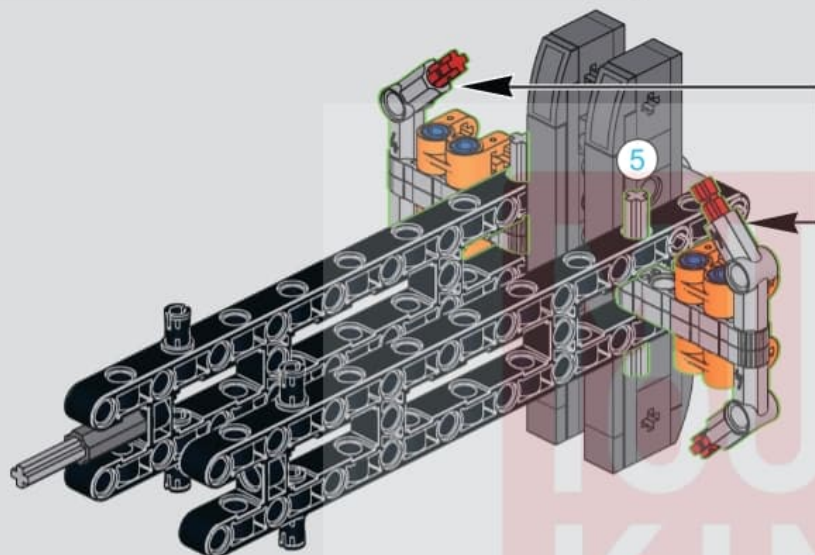

13

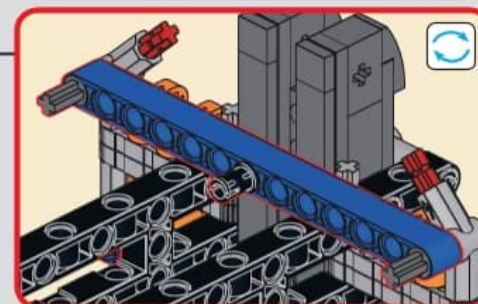
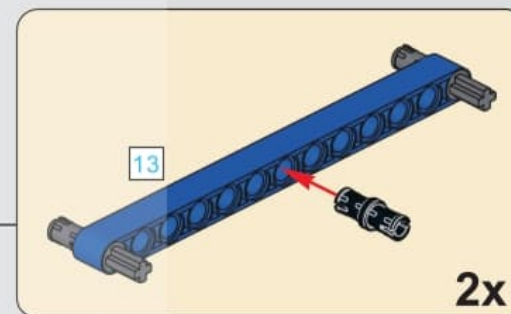
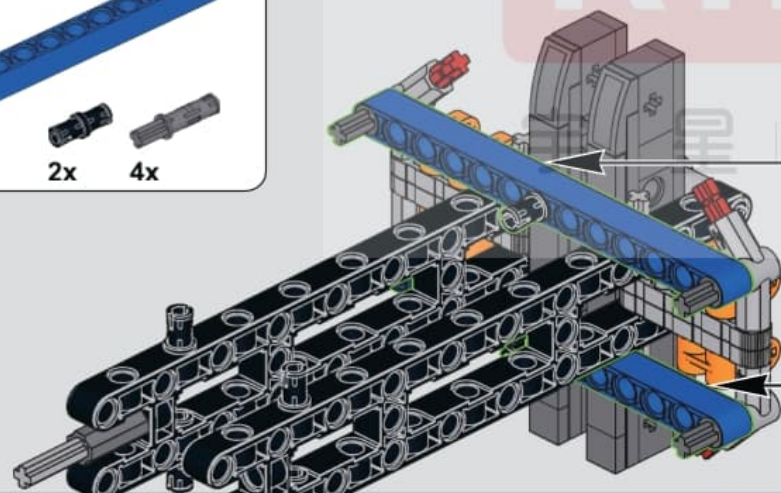





14

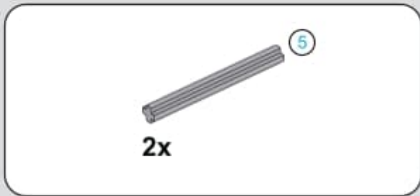
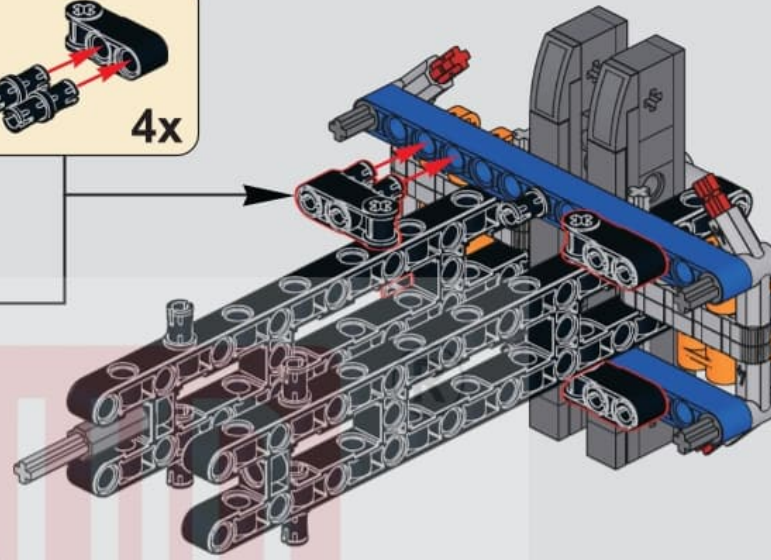
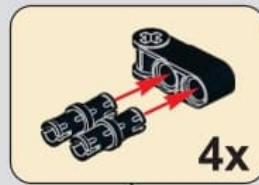
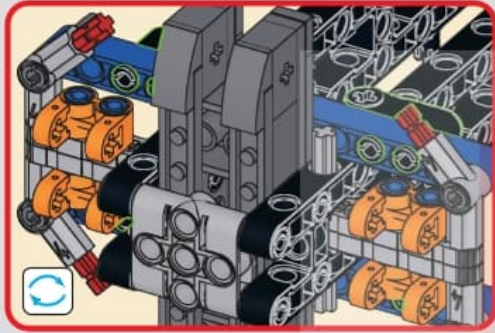

15

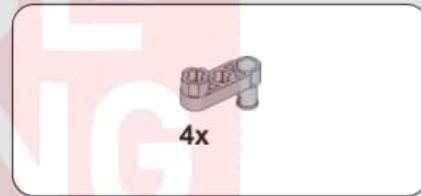
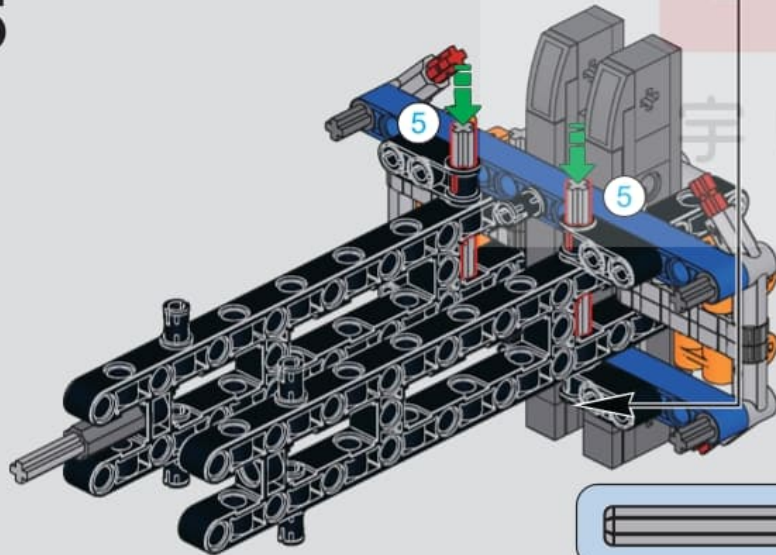
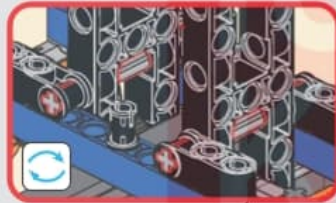

16

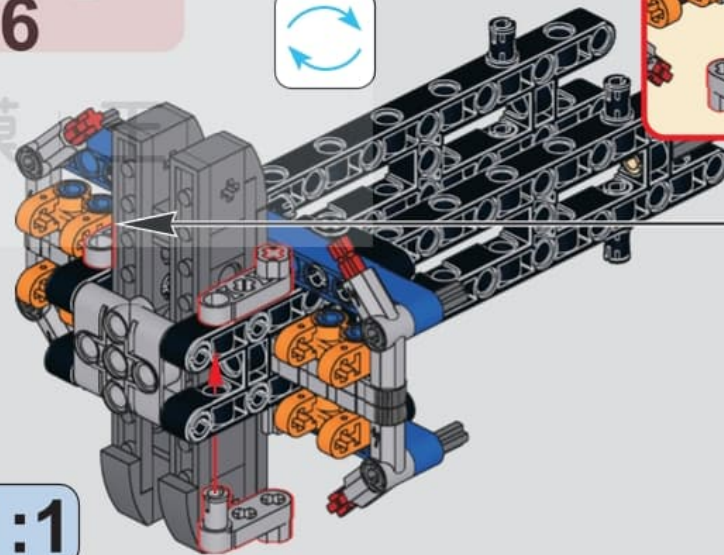
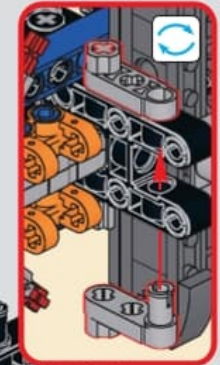



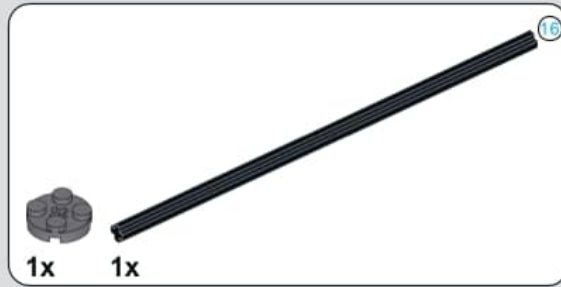
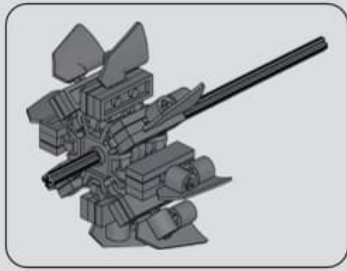

17

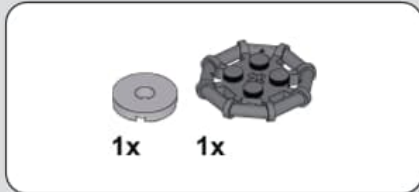
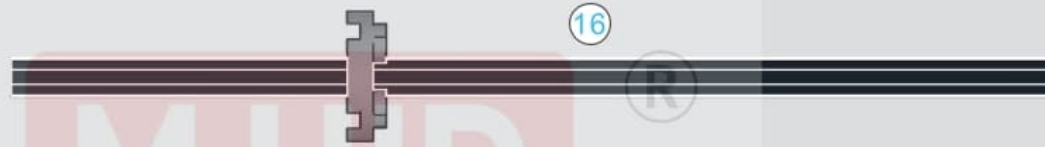

18



19

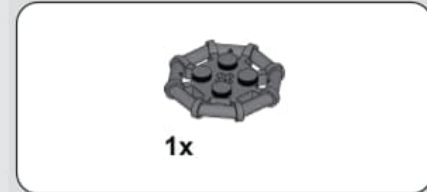

20

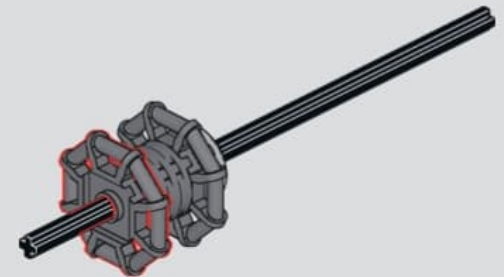
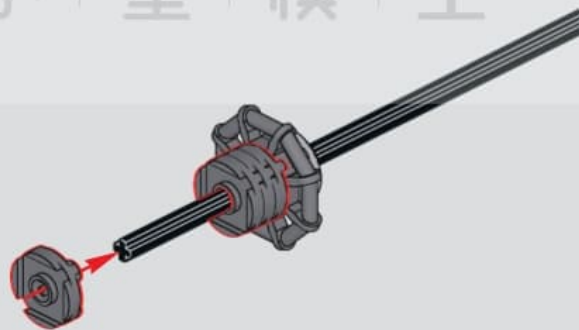
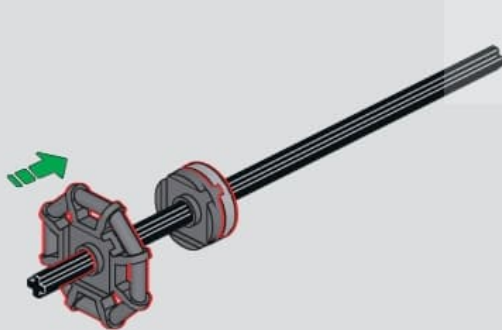

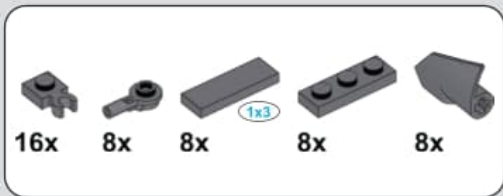

21

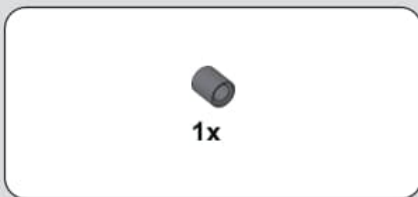
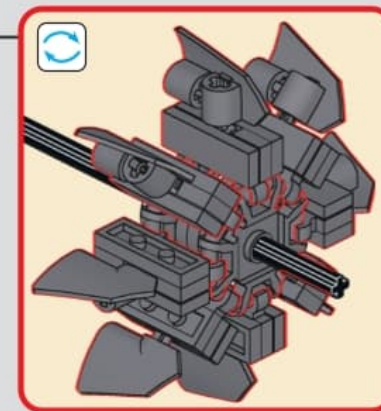
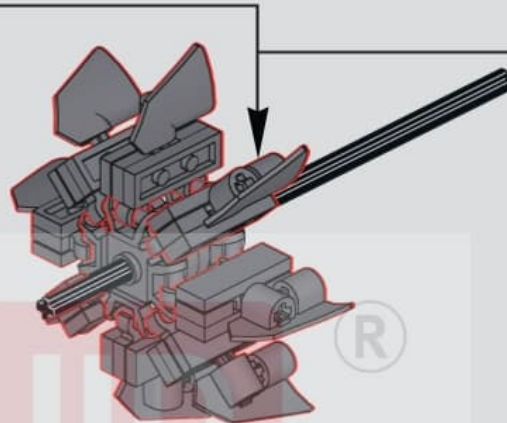
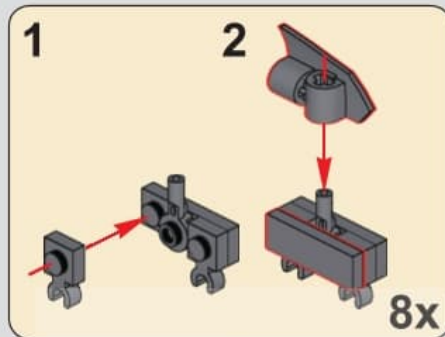

22

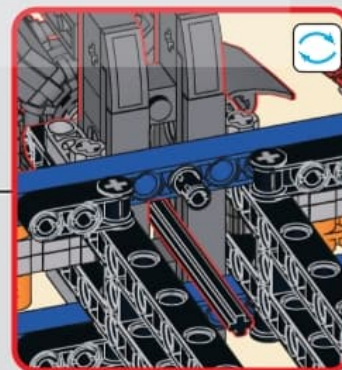
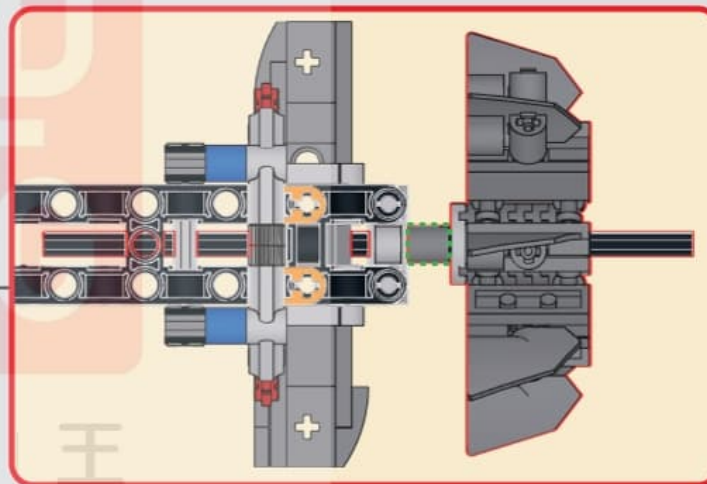
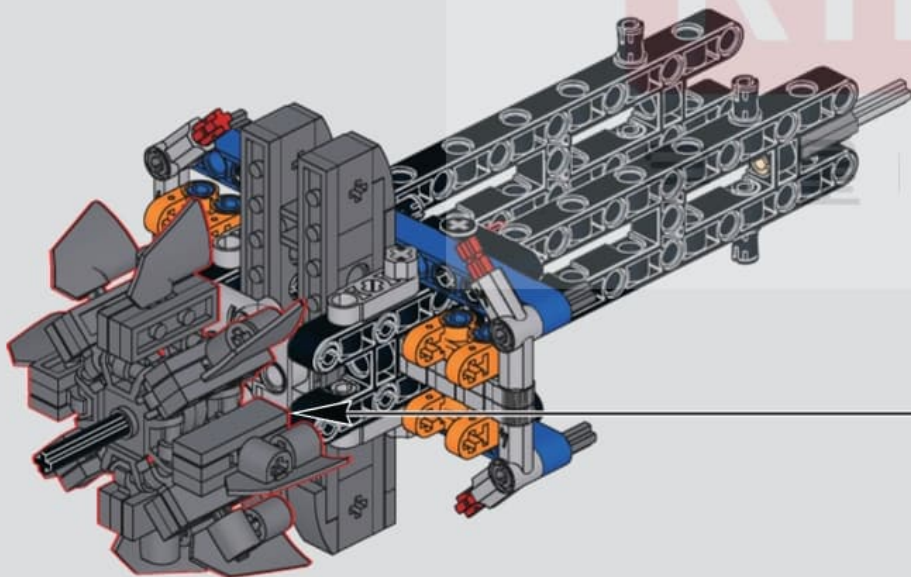

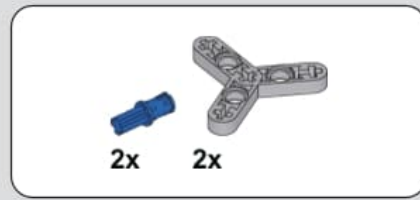
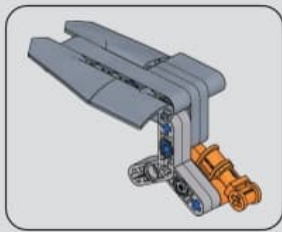

23

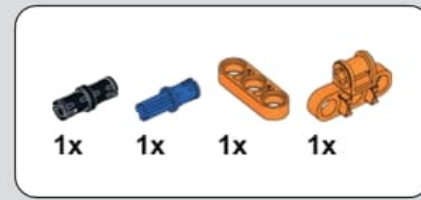

24

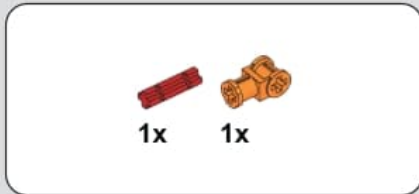
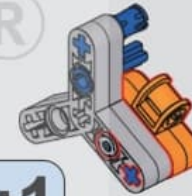
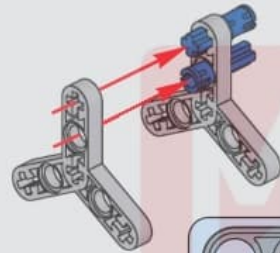
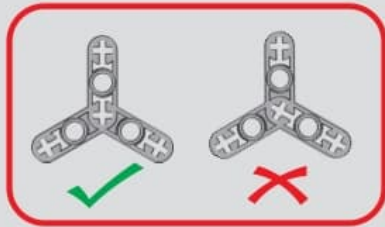
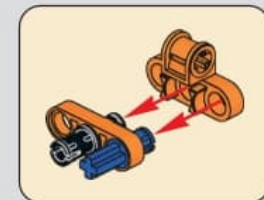

25

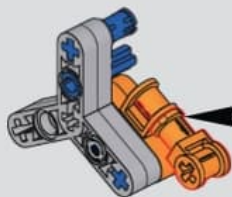
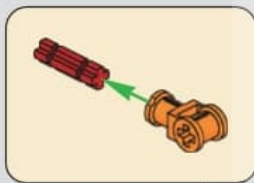

26

宇 | 星 | 模 | 王

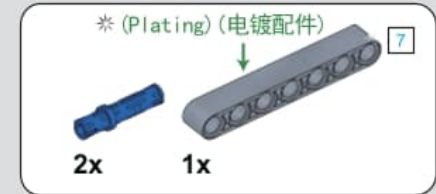
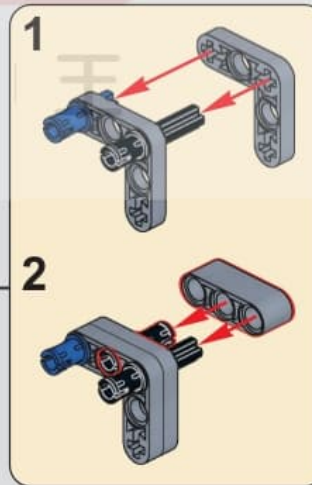
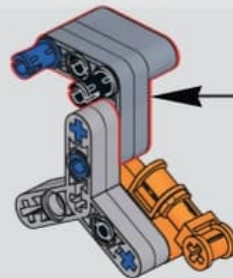

27

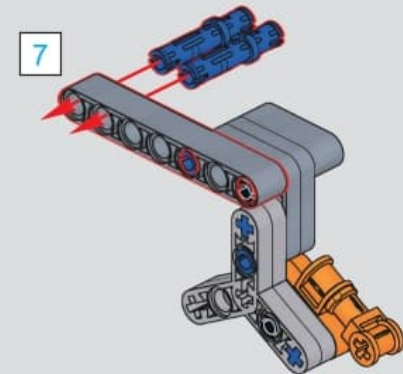



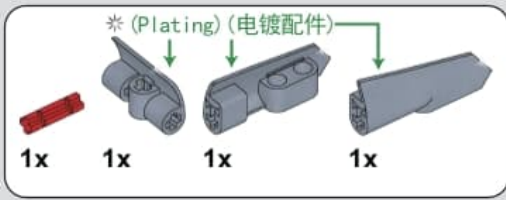

28

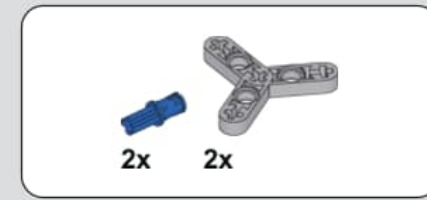
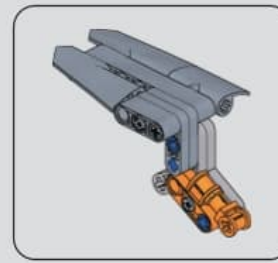

29

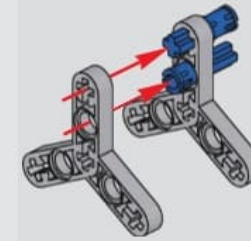
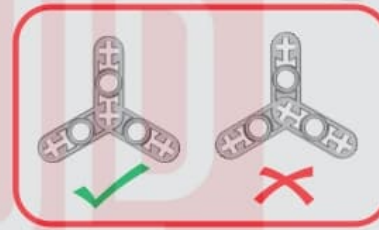
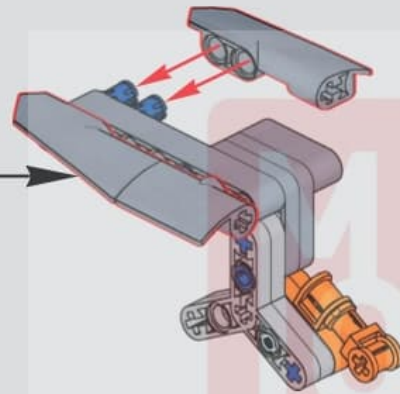
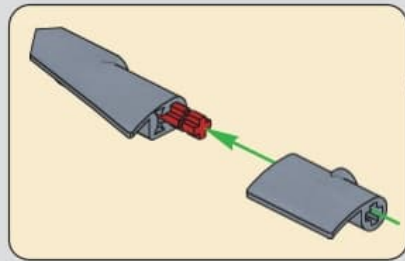

30

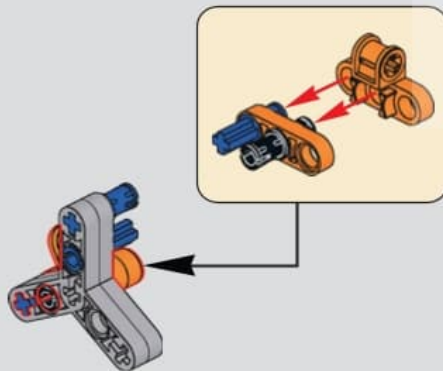

31

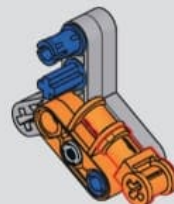

32

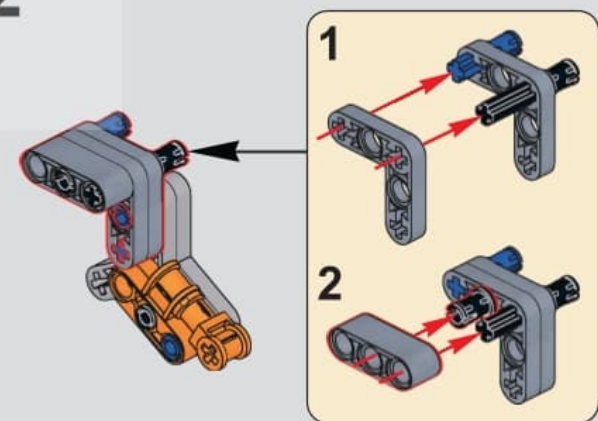

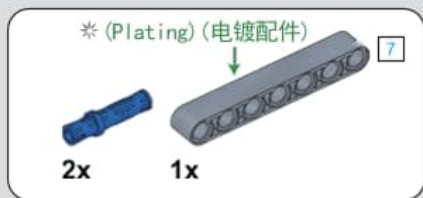

33

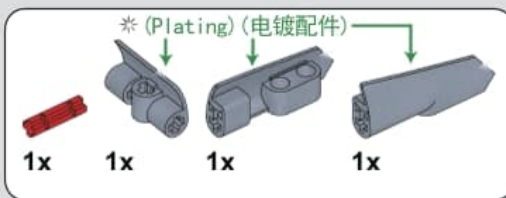
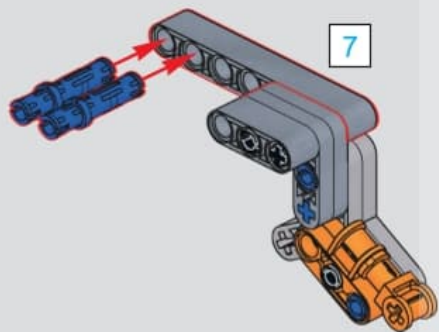

34

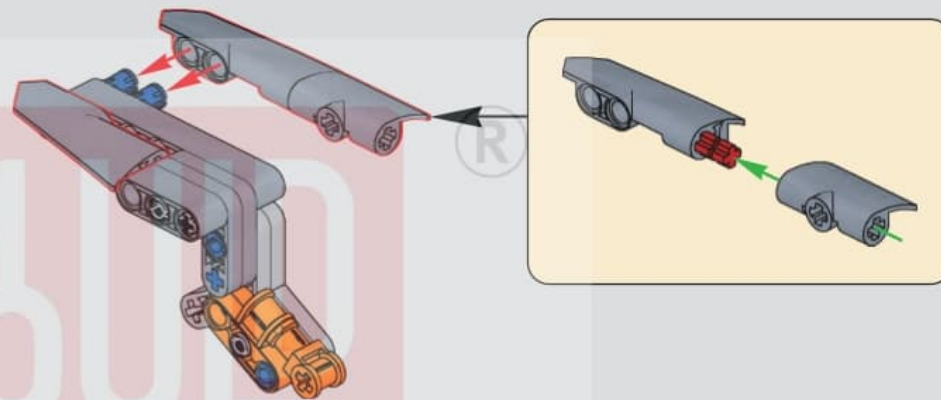

35

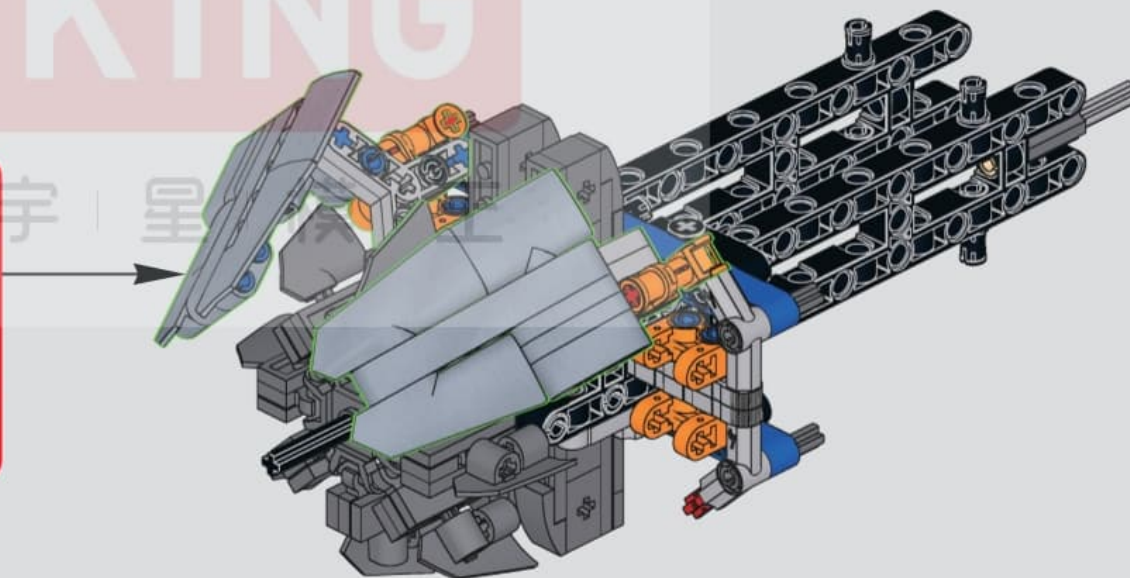
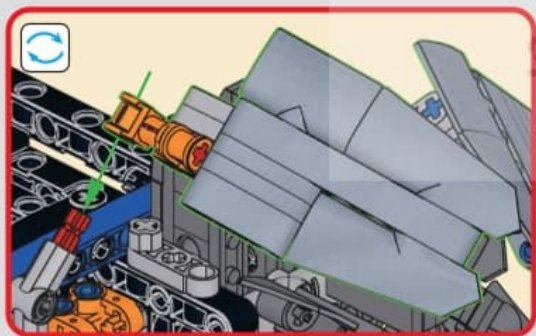

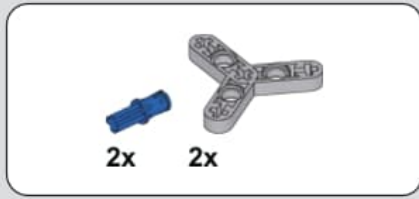
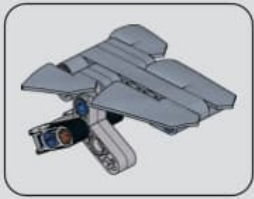

36

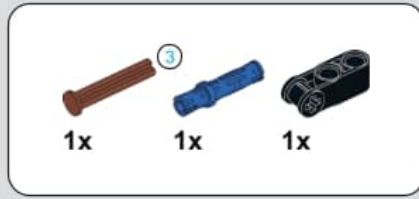

37

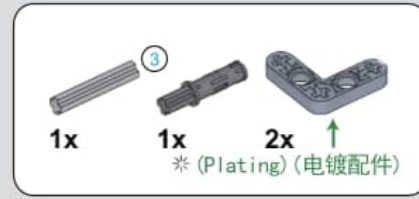

38

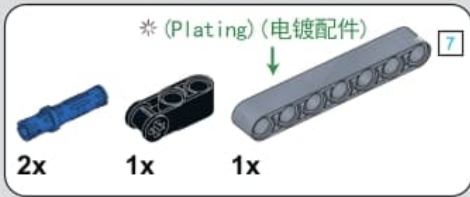
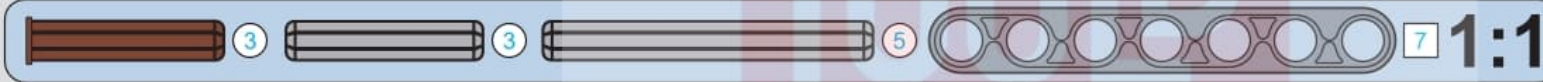
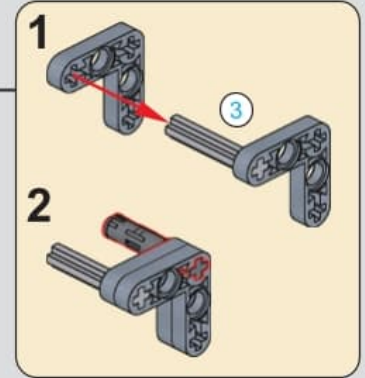
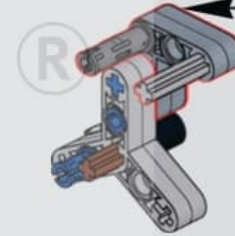
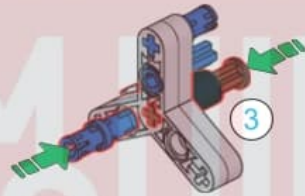
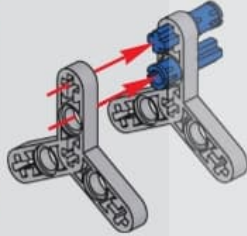
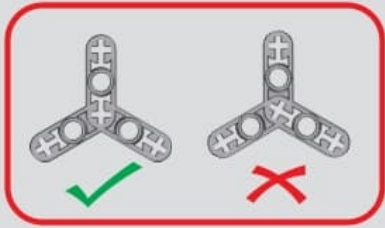

39



40

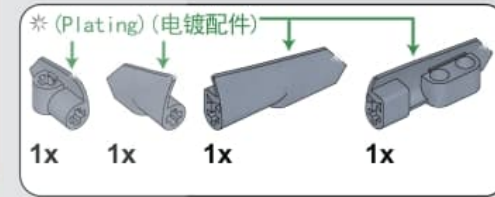

41

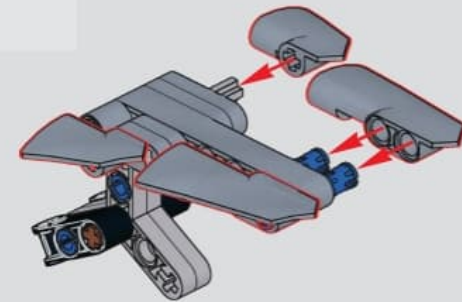
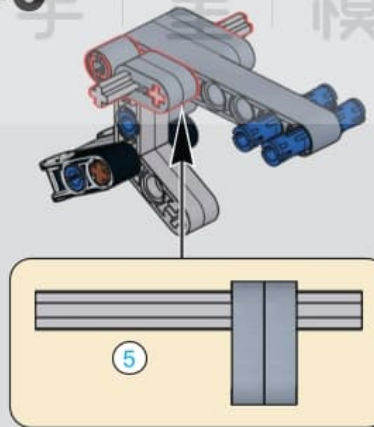
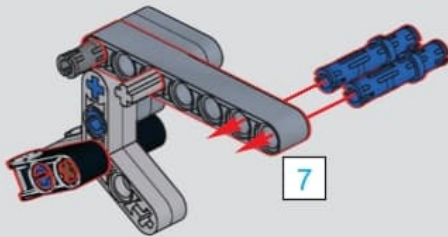



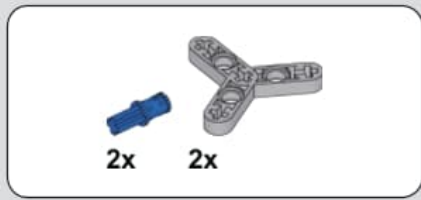
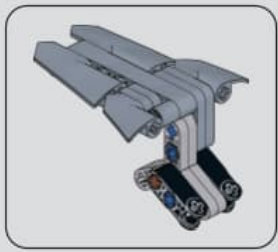

42



43

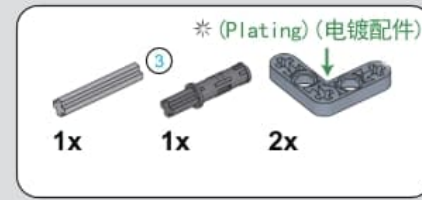

44

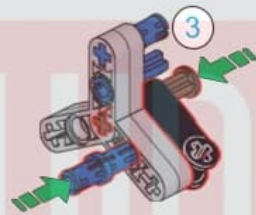
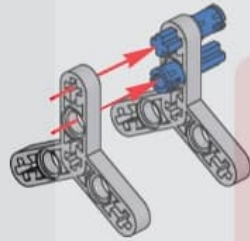
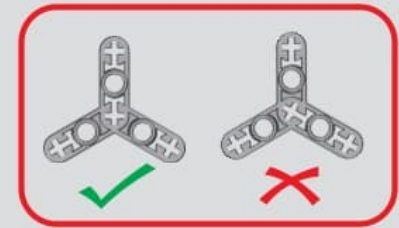

®

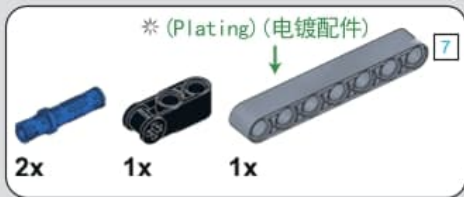
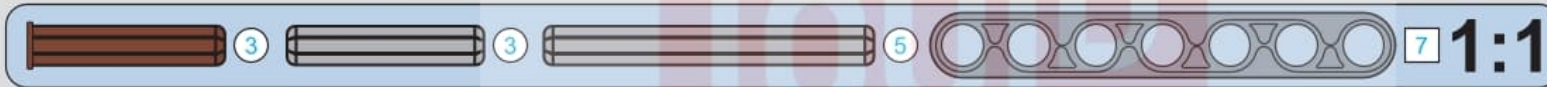
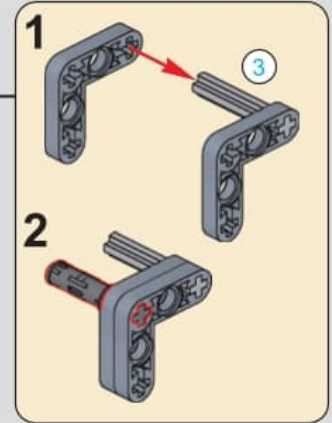
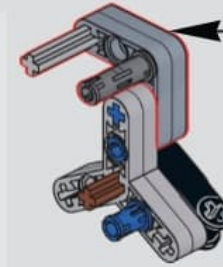

45

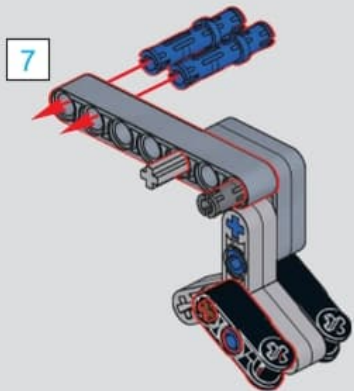

46

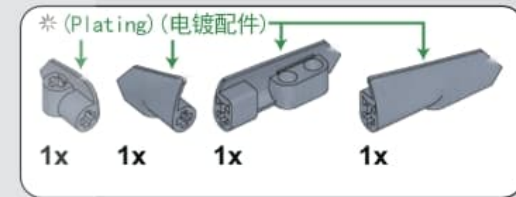
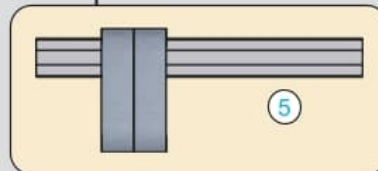
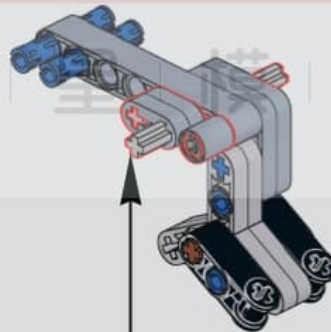

47

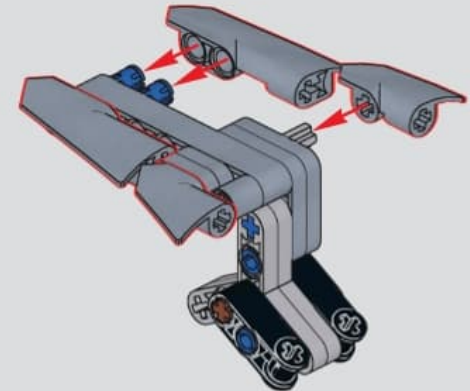

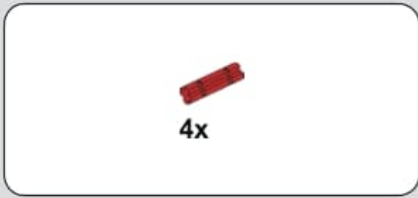

48

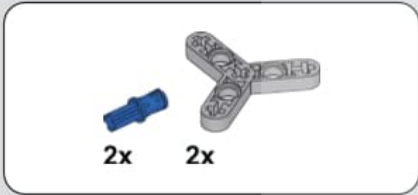
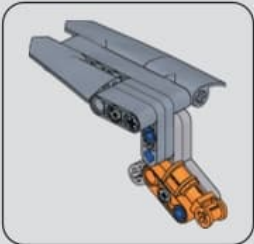
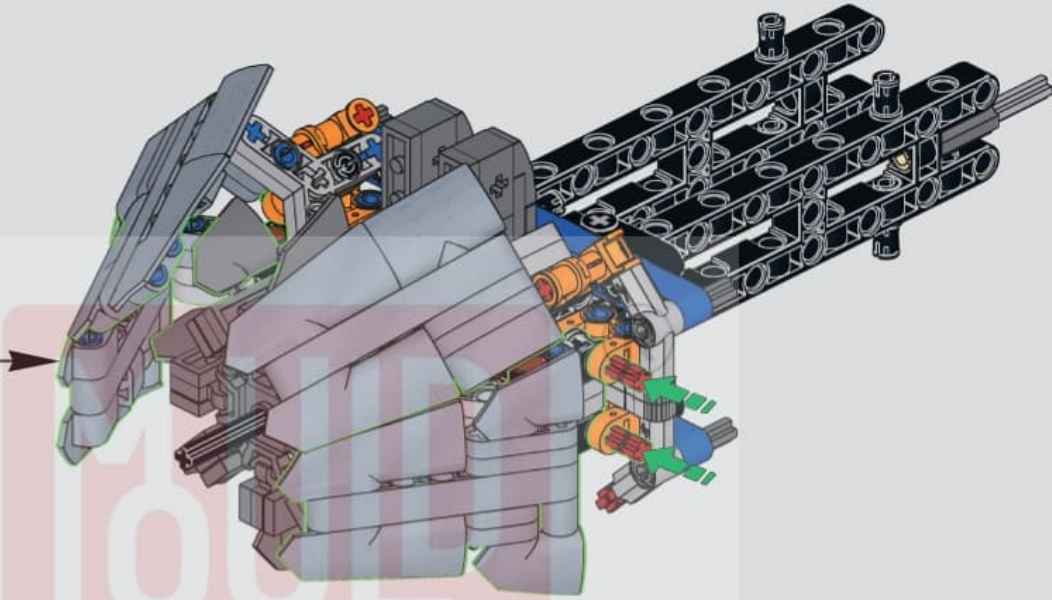
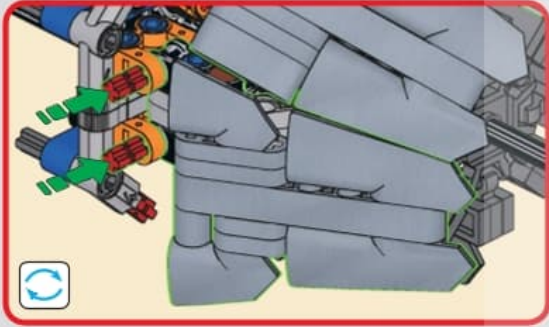

49

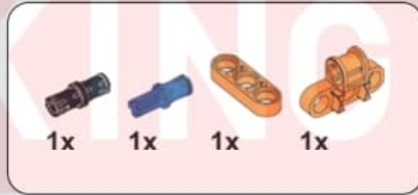

50

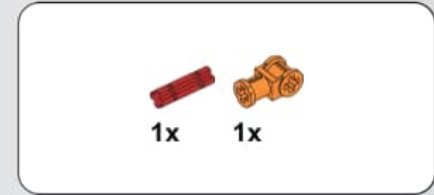
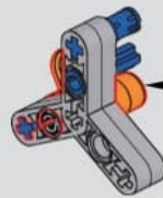
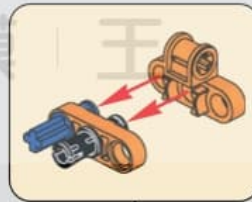

51

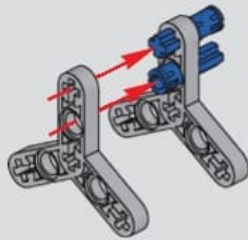
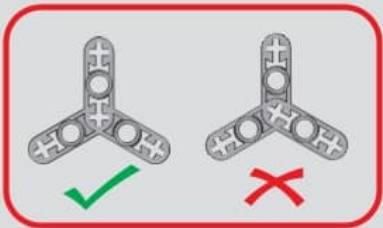
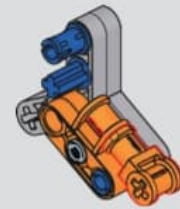
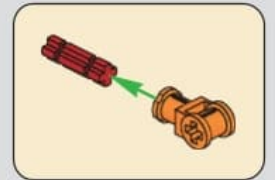



52

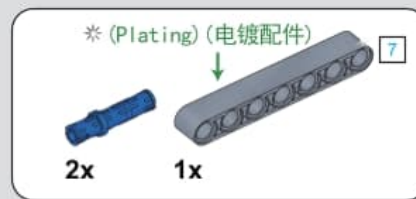
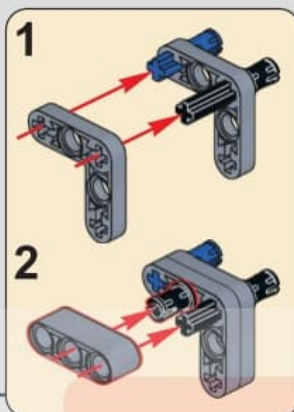
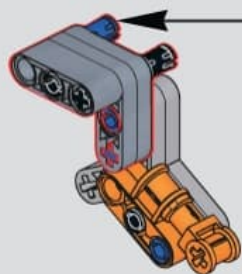

53

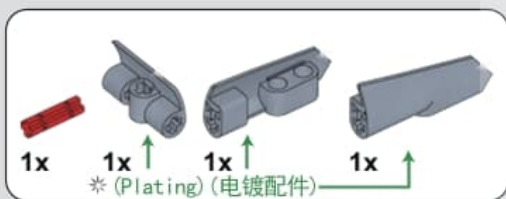
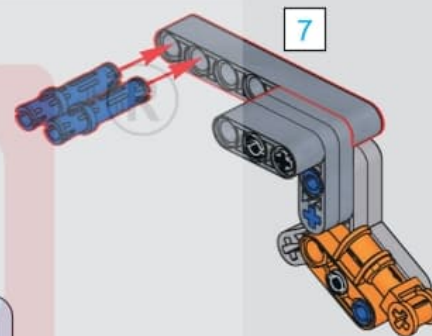

54

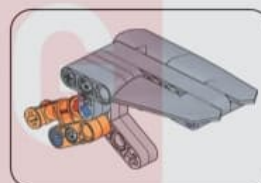
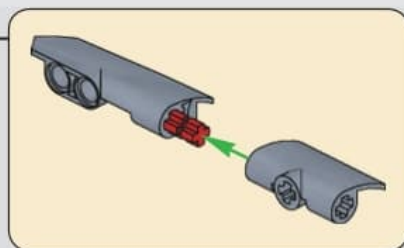
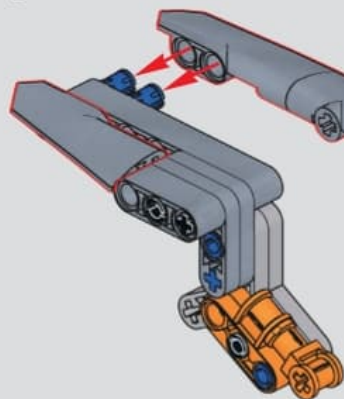

55

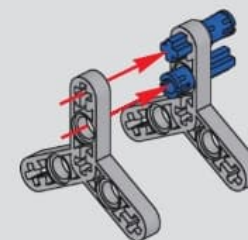
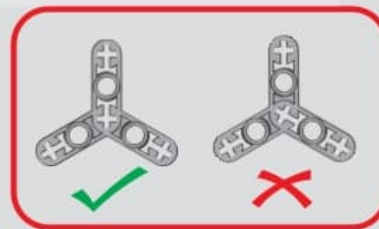
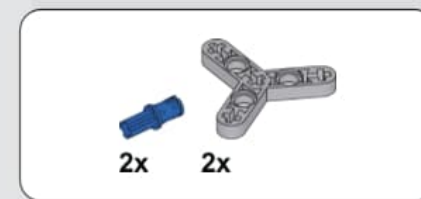



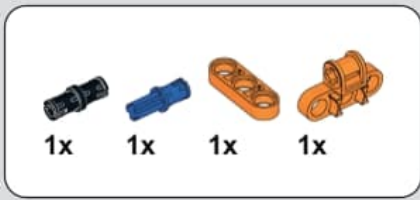

56

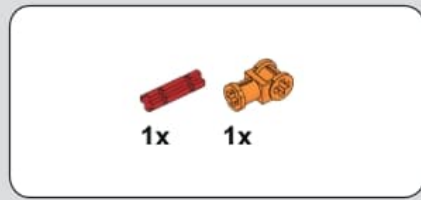
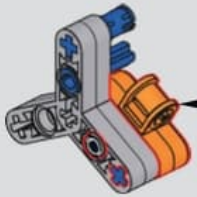
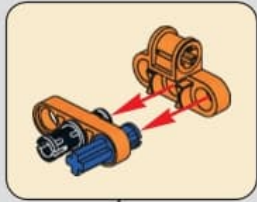

57

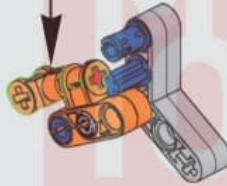

58

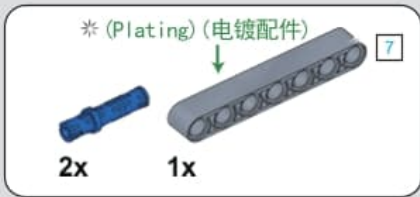
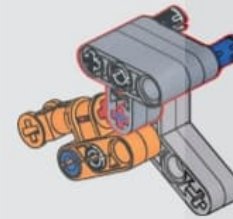
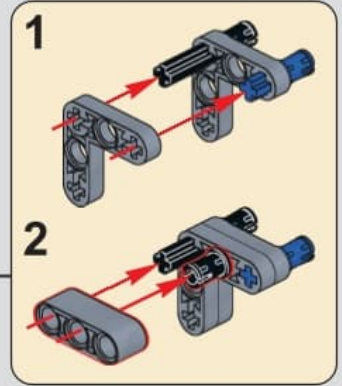

59

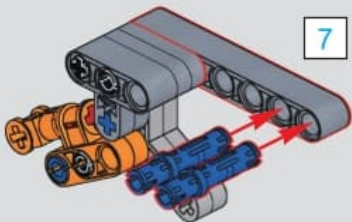

60

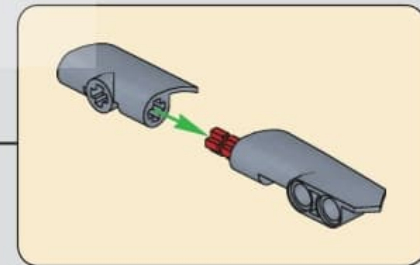
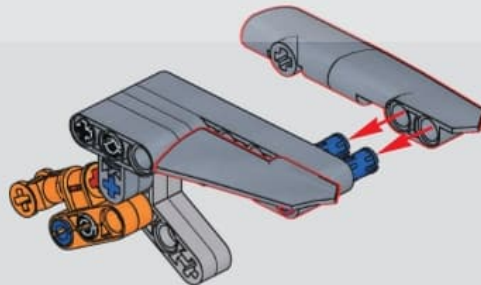

61

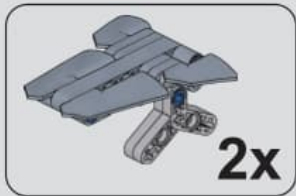
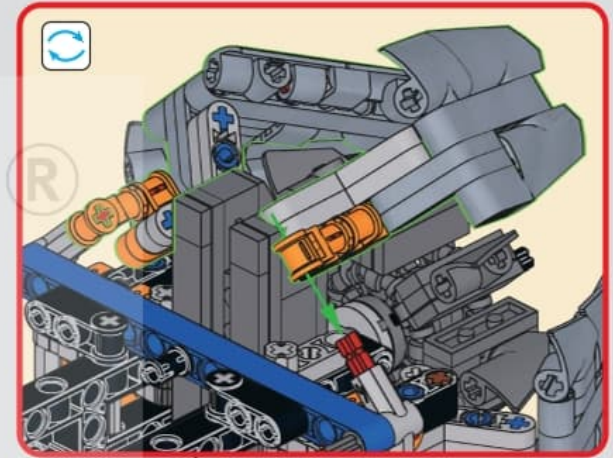
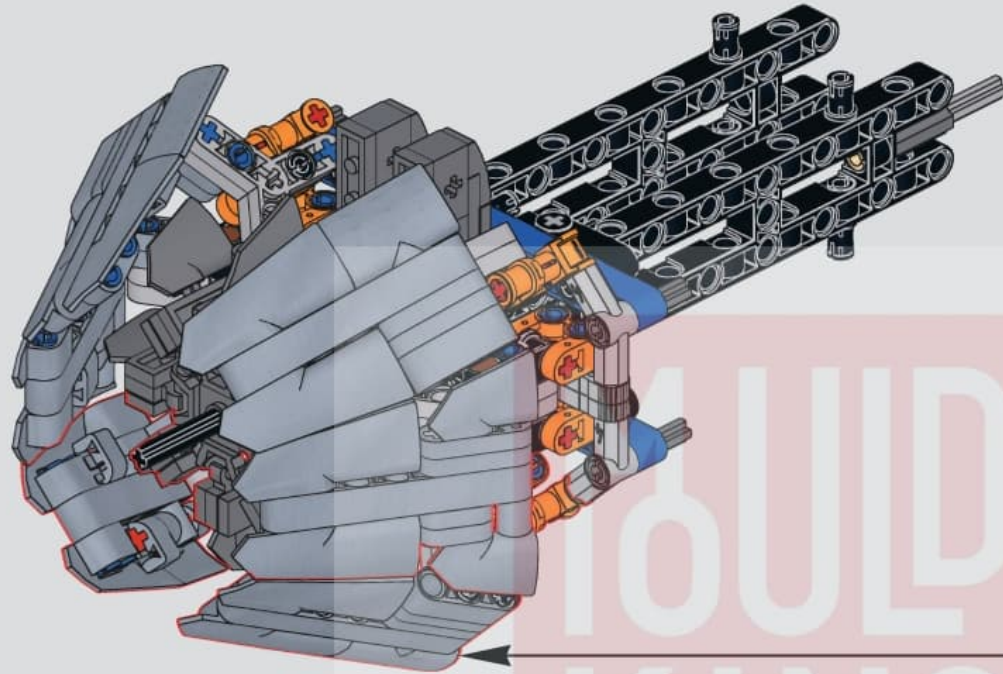

2x

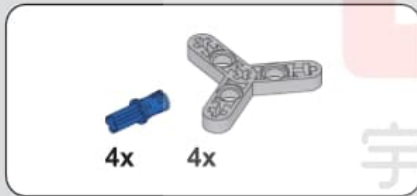

4x

4x

62

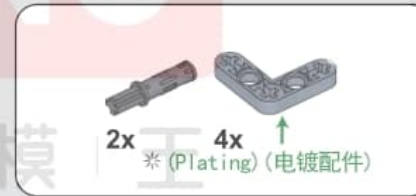

2x

4x

\* (Plating) (电镀配件)

63

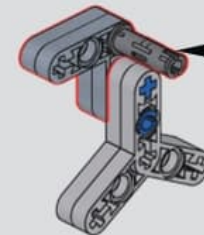
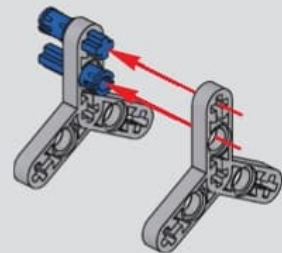
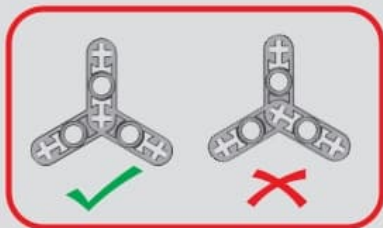
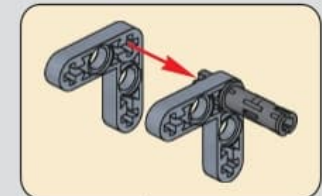



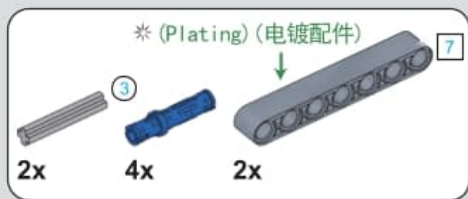

64

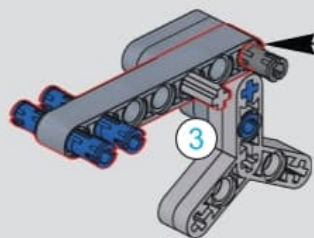
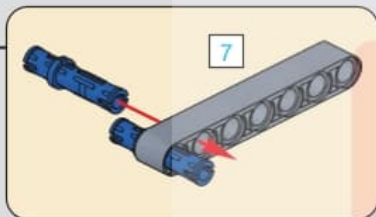

65

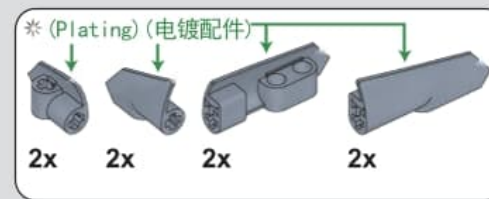
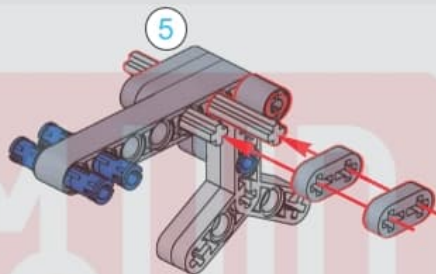

66

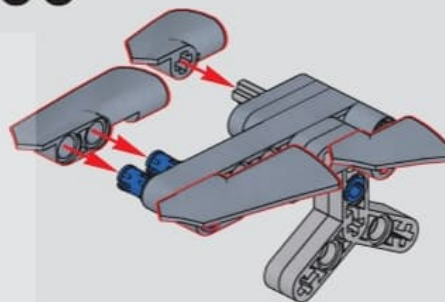

2x

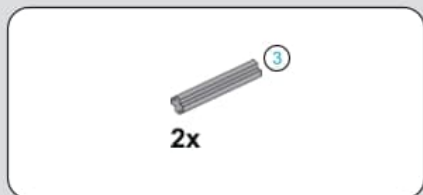

67

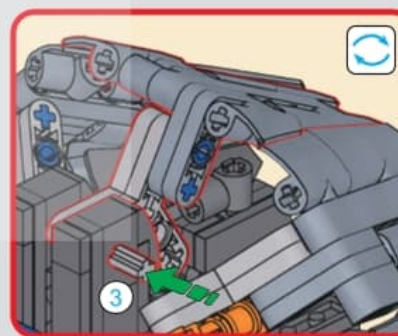
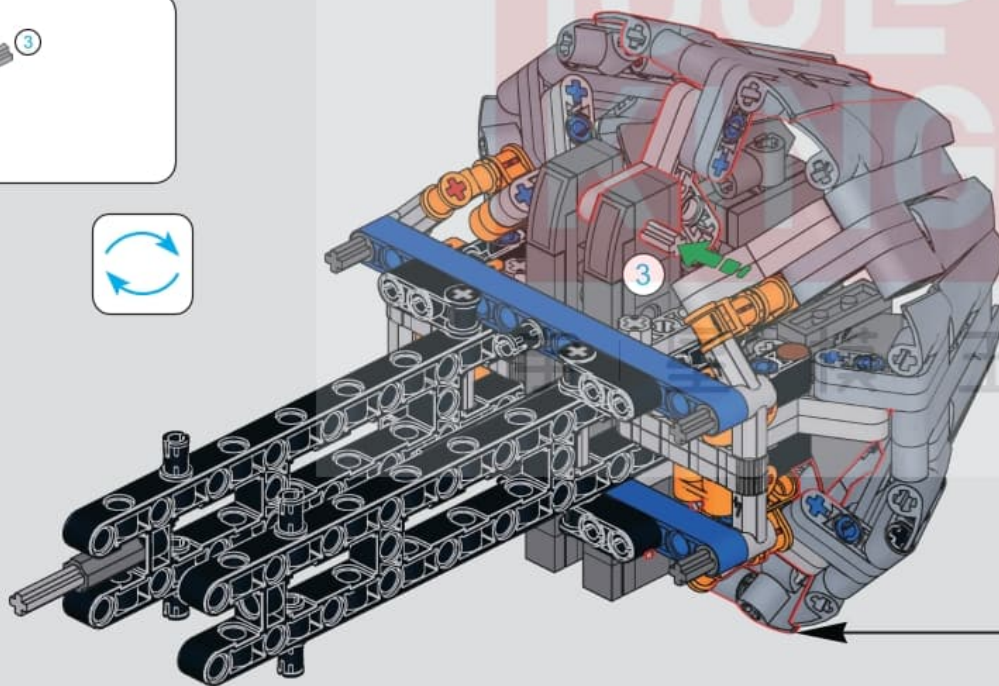



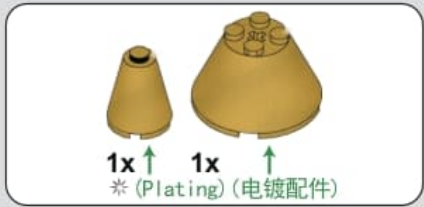

68

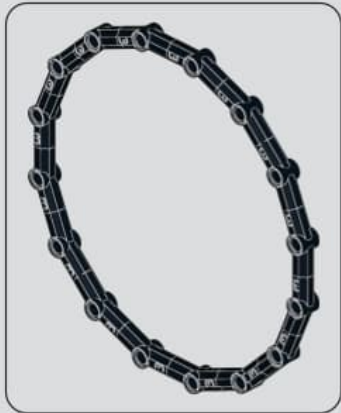
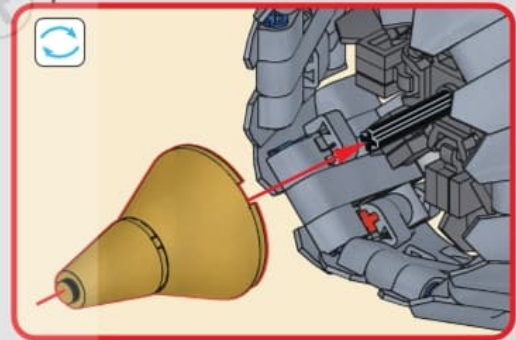
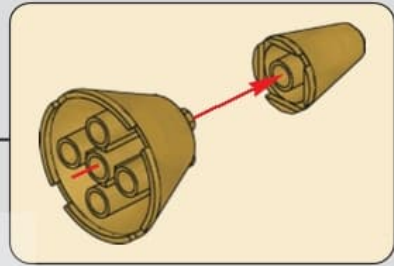
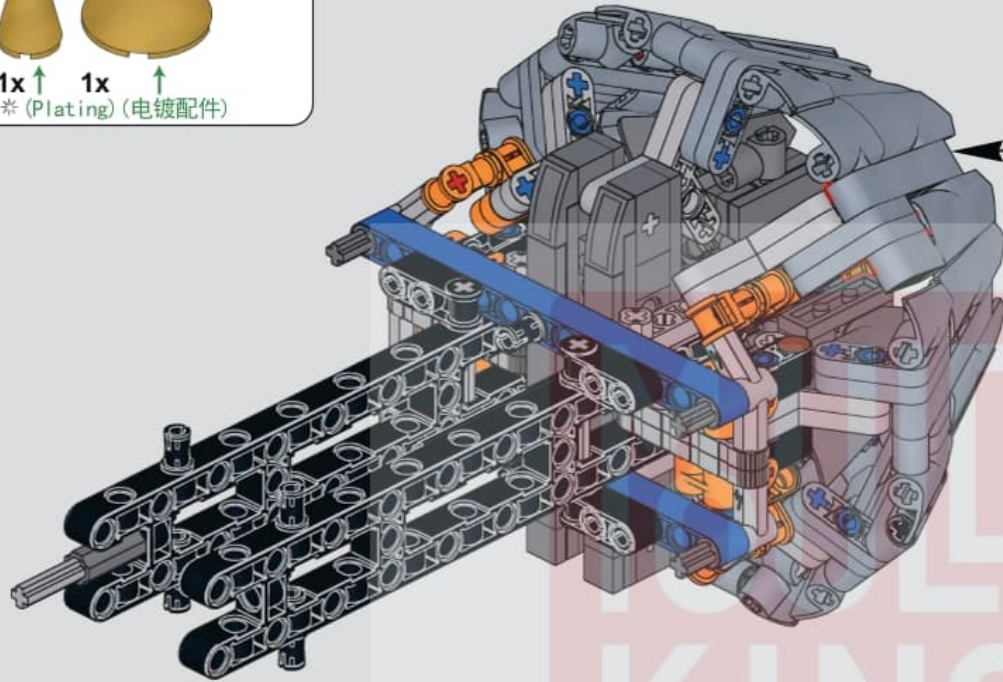

69



70

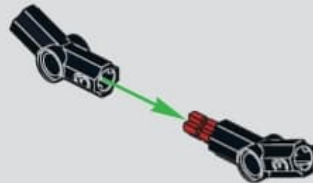
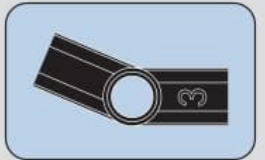

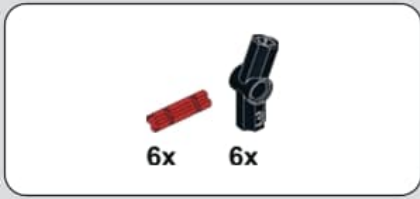

71

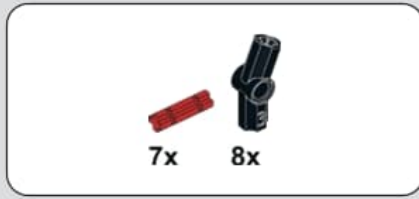
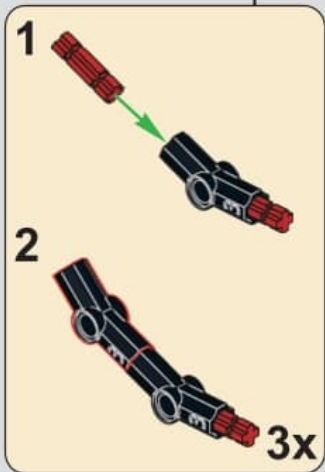
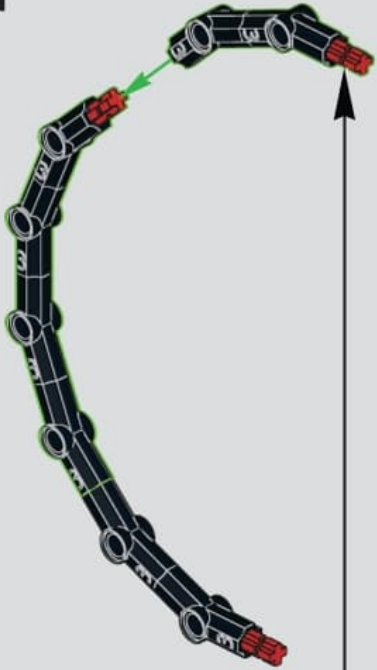

72

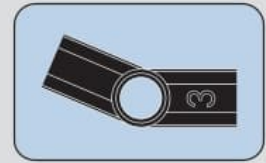
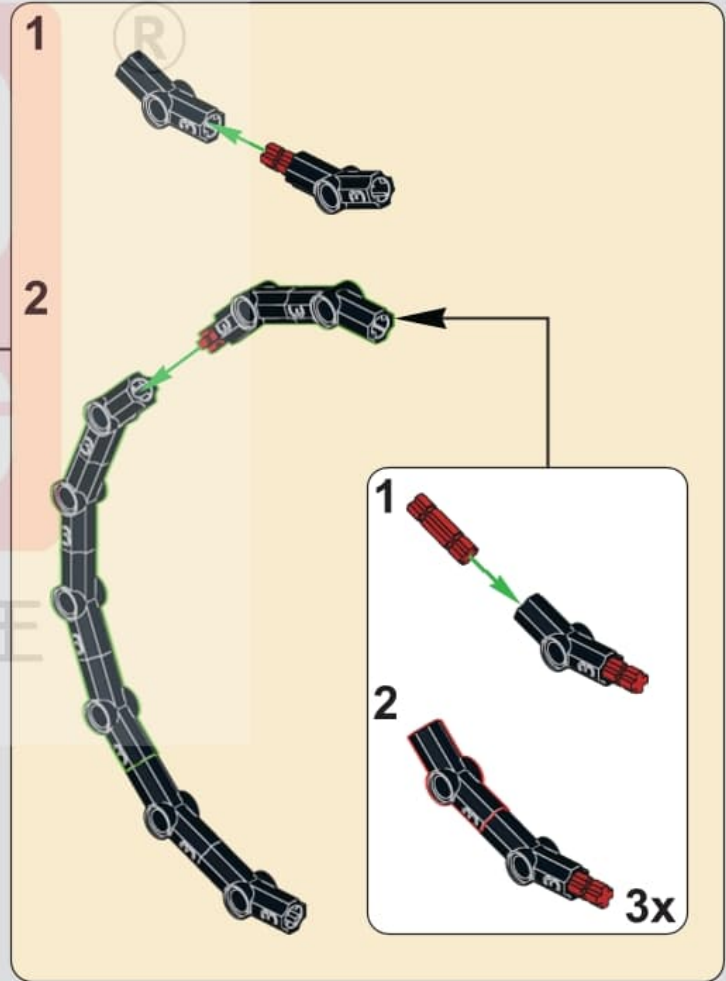

73

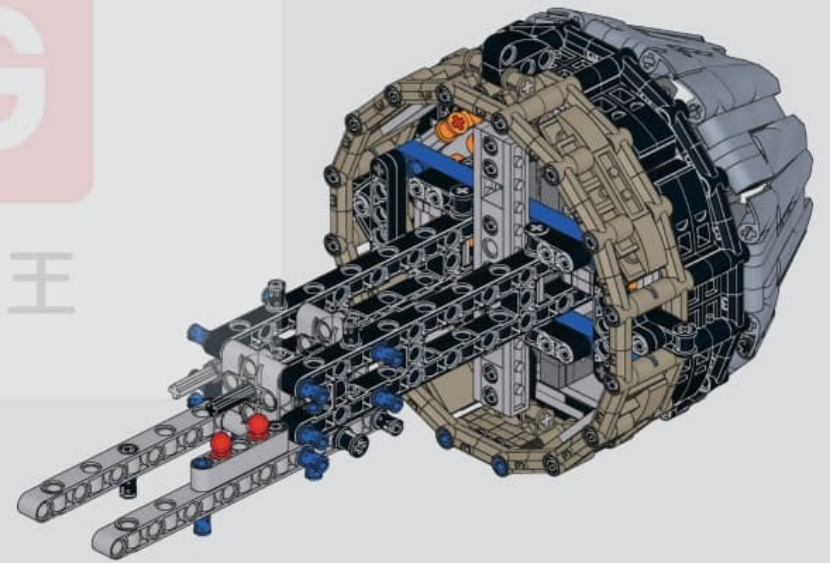
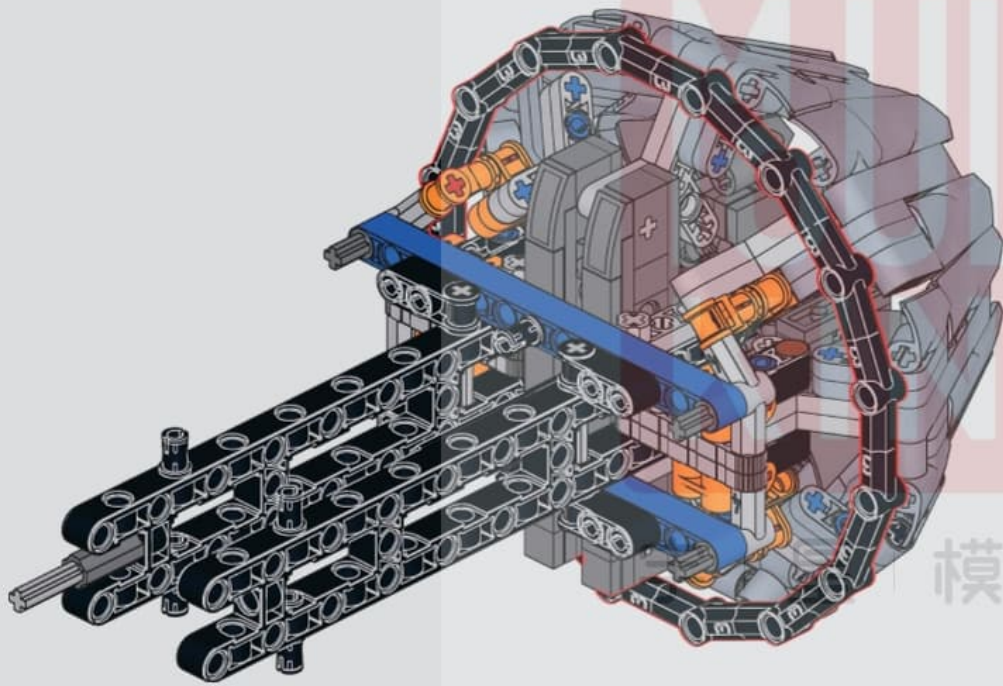



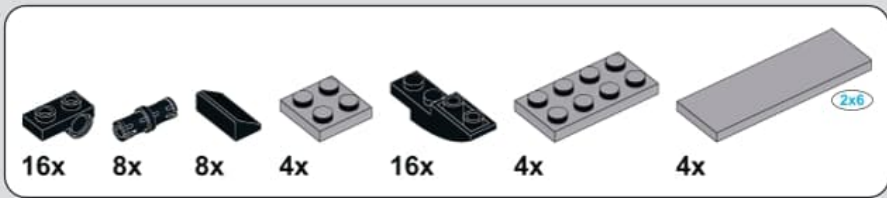

# 74

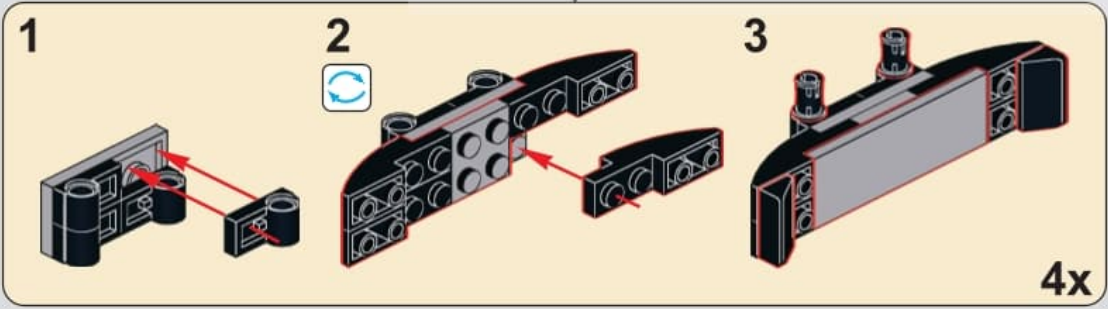
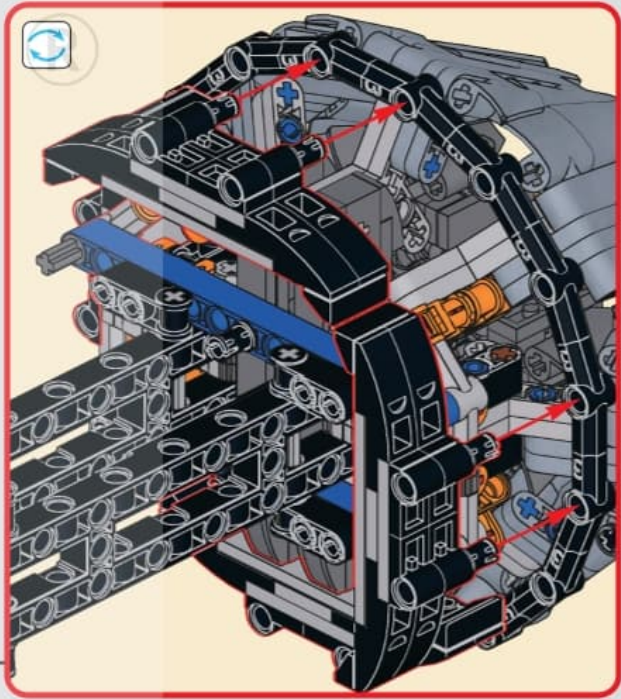
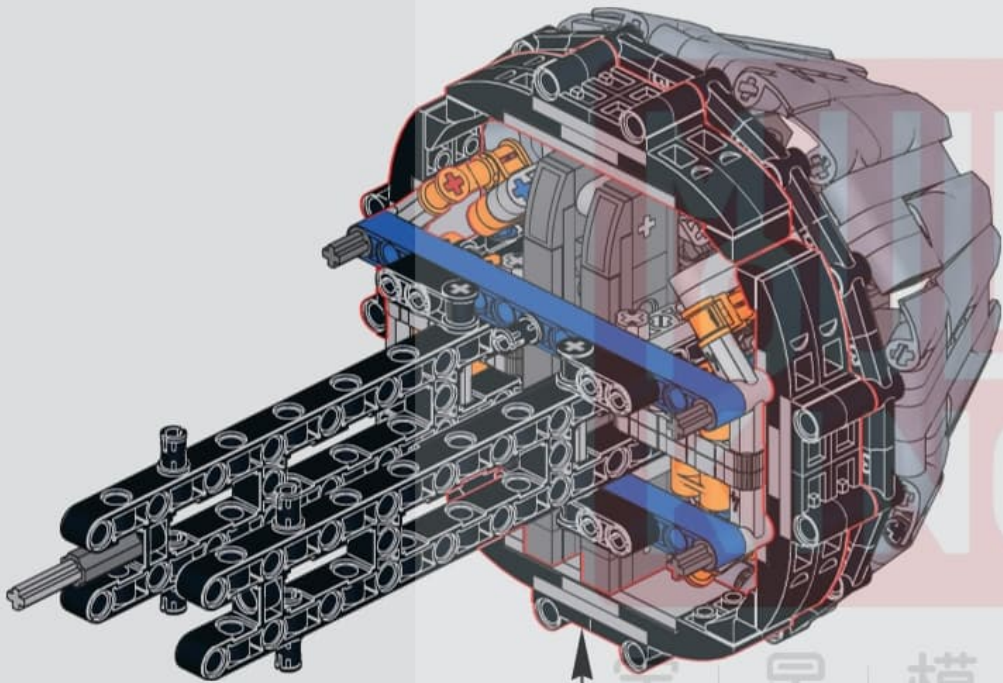

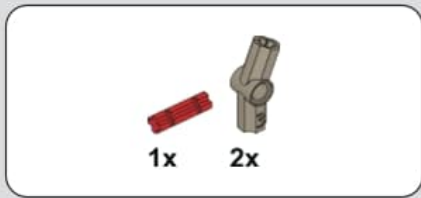
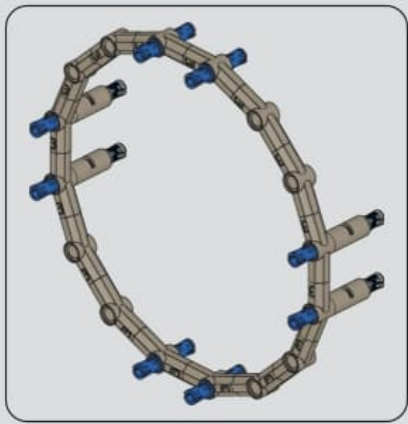

75

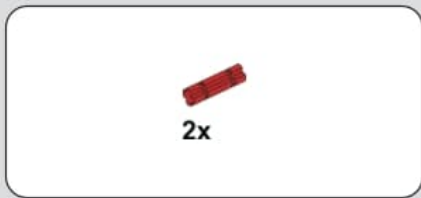
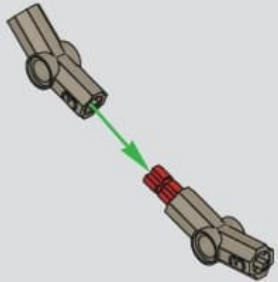

76

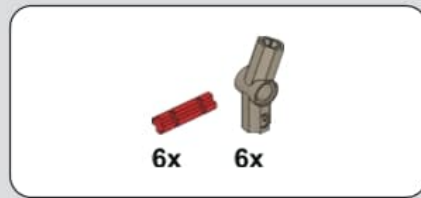

77

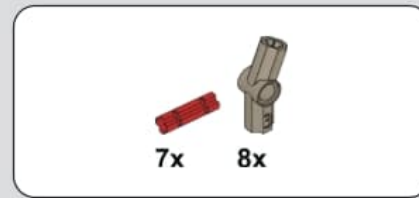
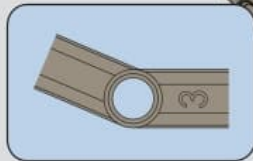
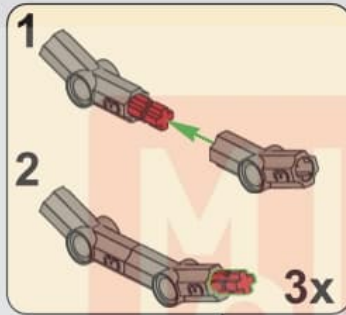

78

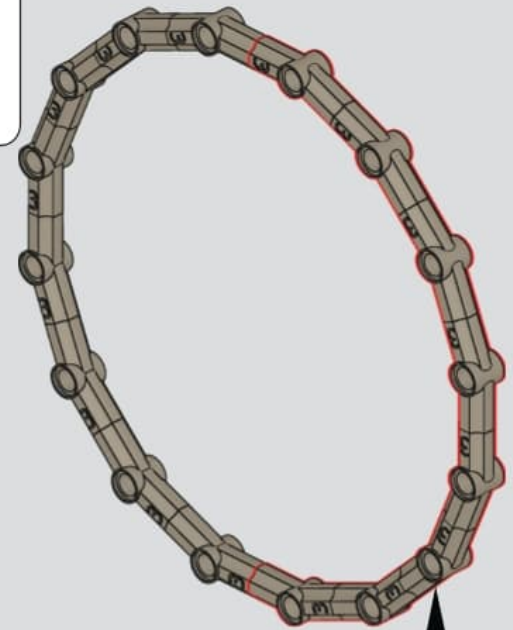
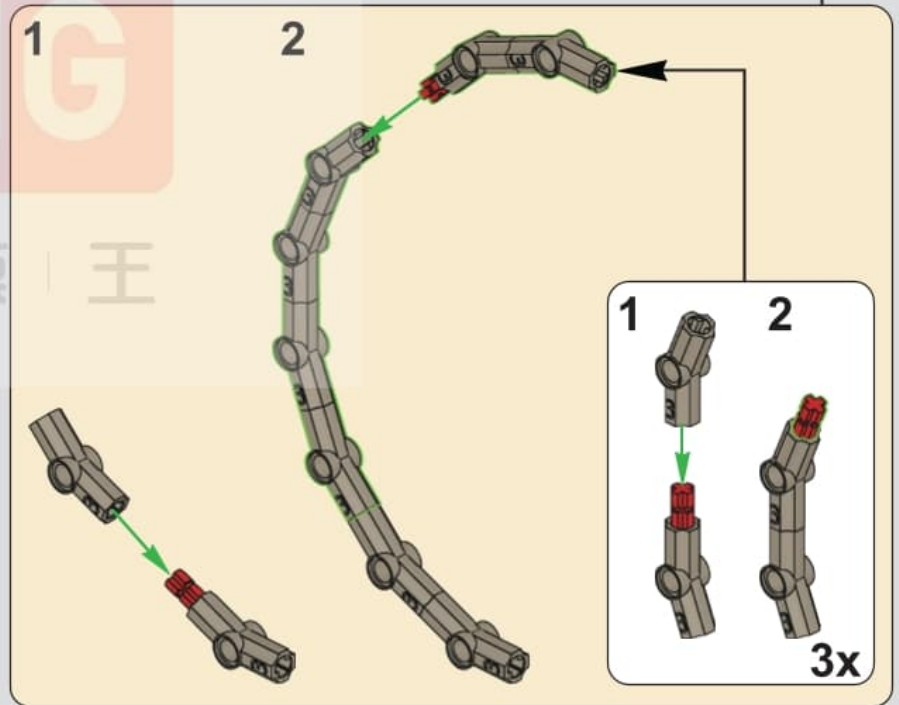



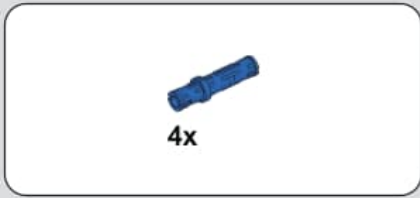

79

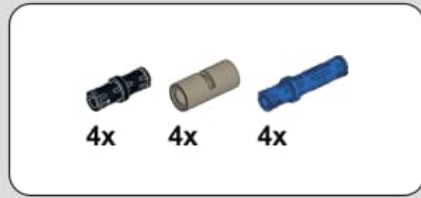
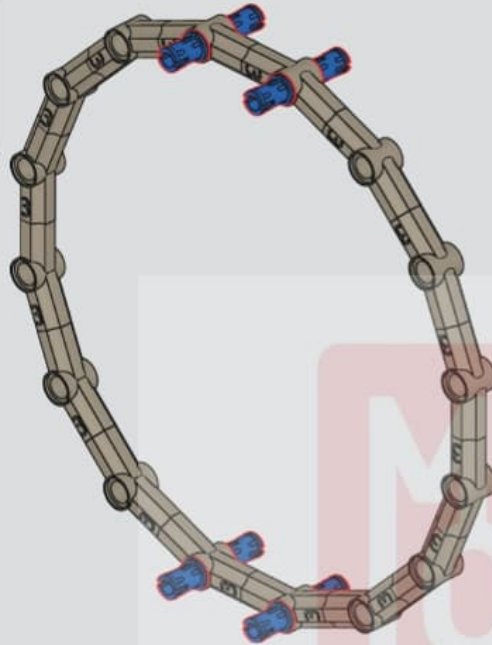

80

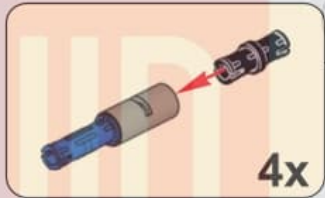
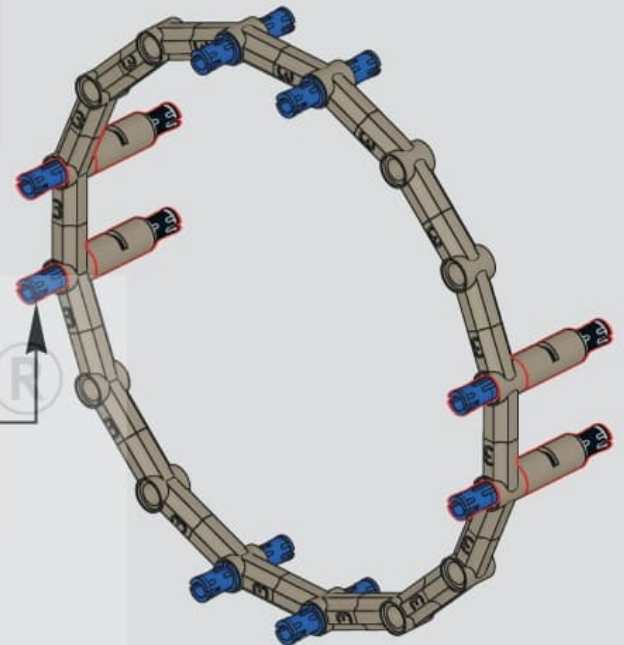

81

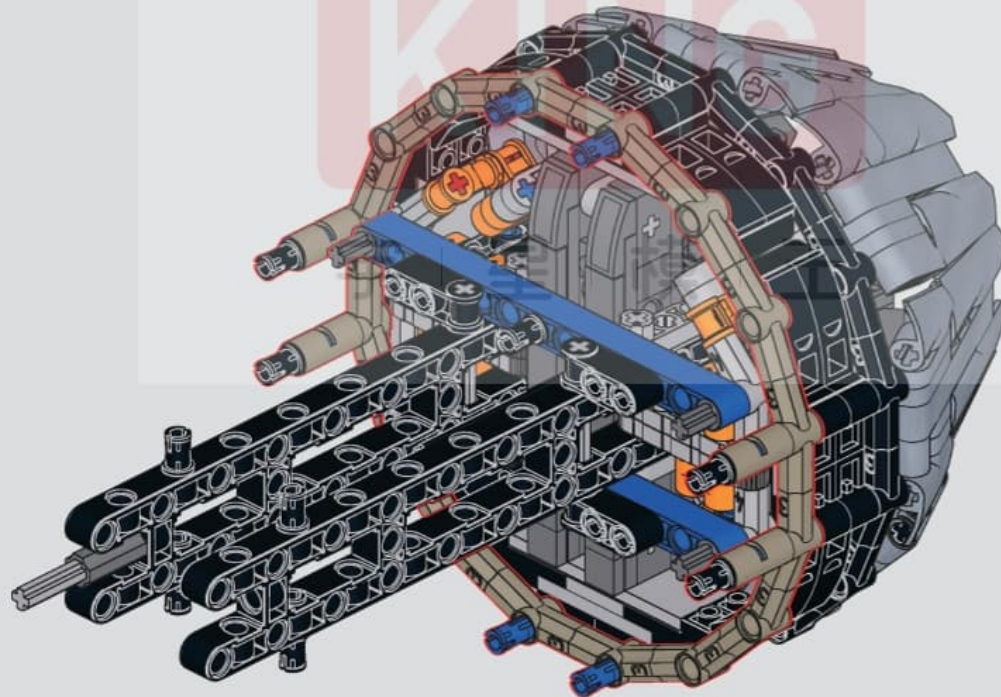



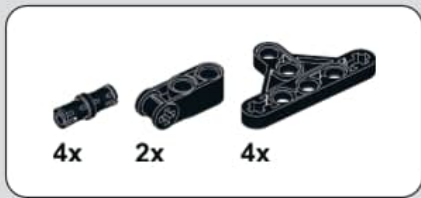

82

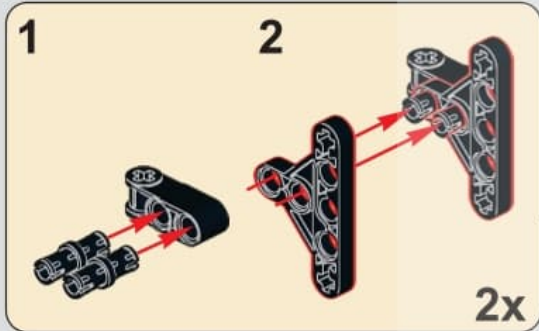
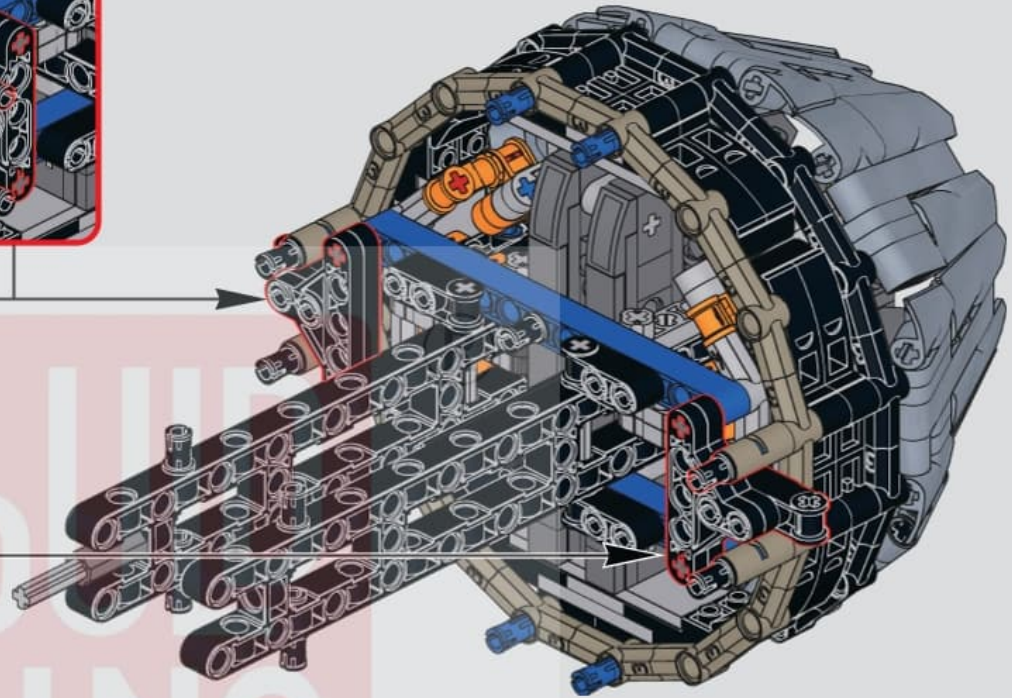
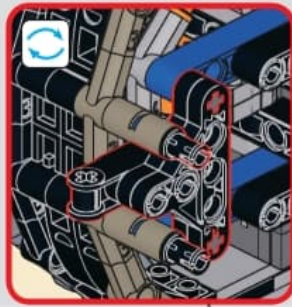

83



84

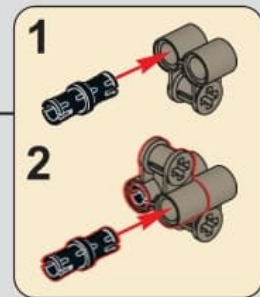
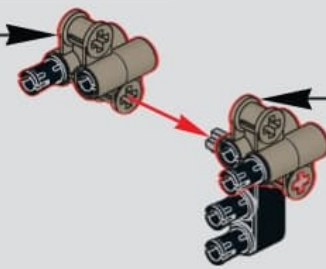
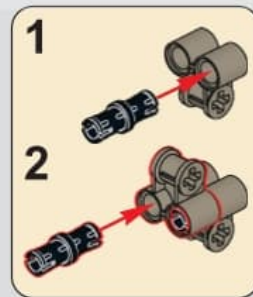
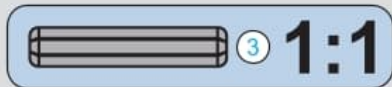
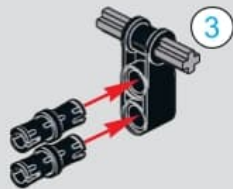

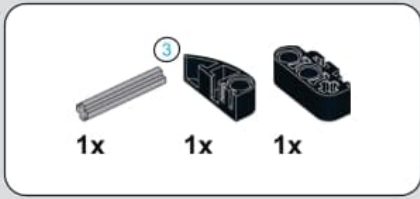

85

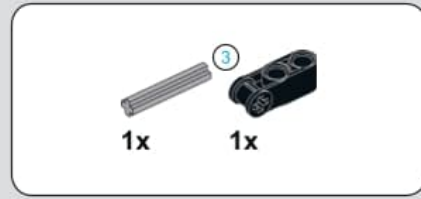
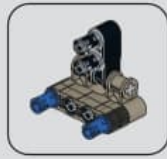
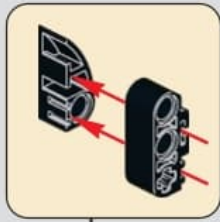
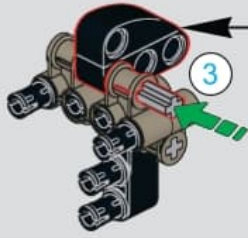

86

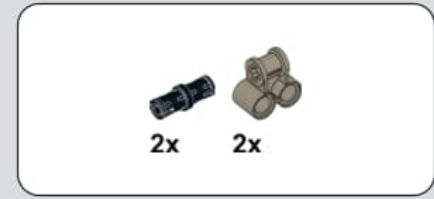

87

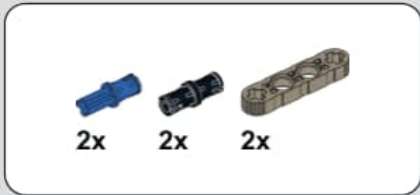
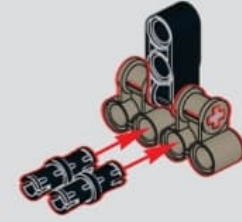

88

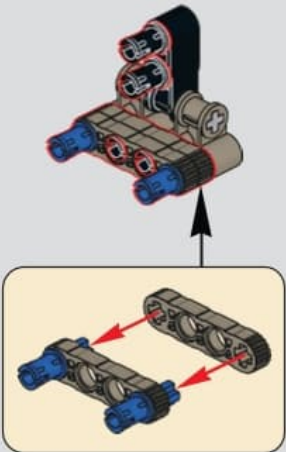

89

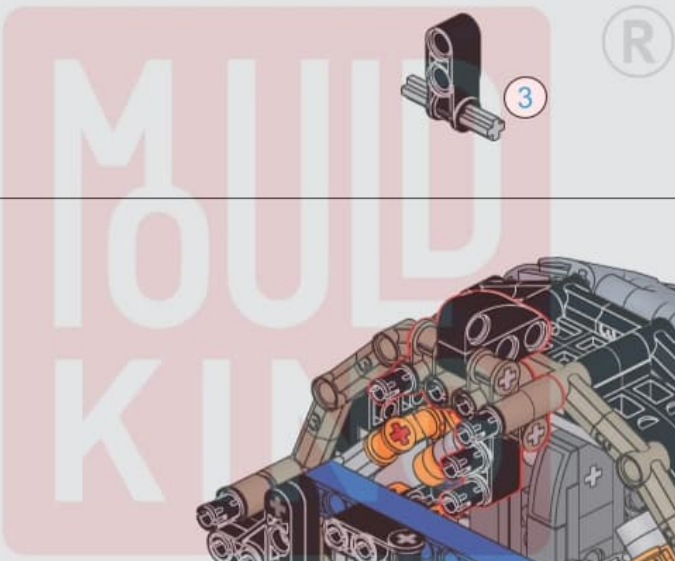
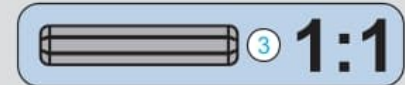
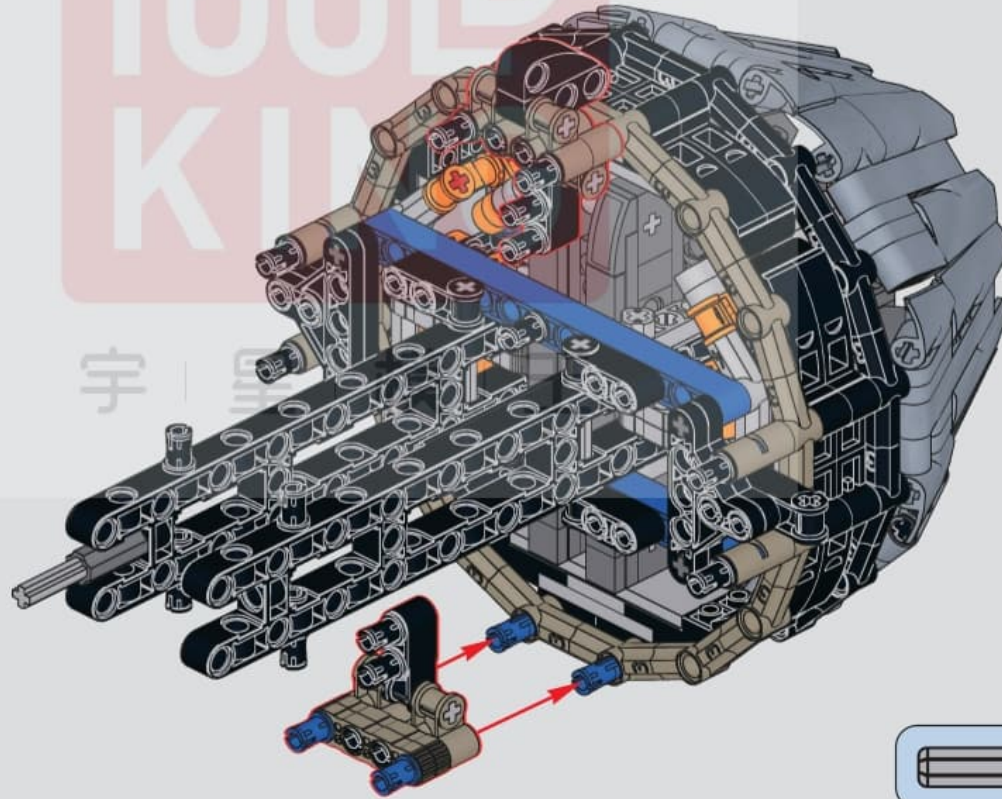



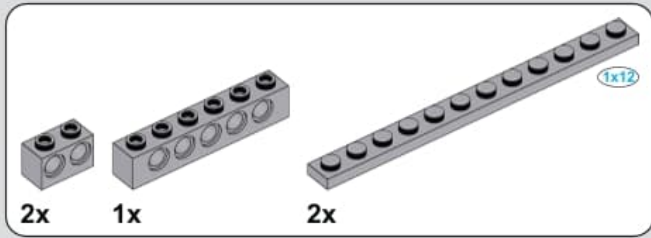

90

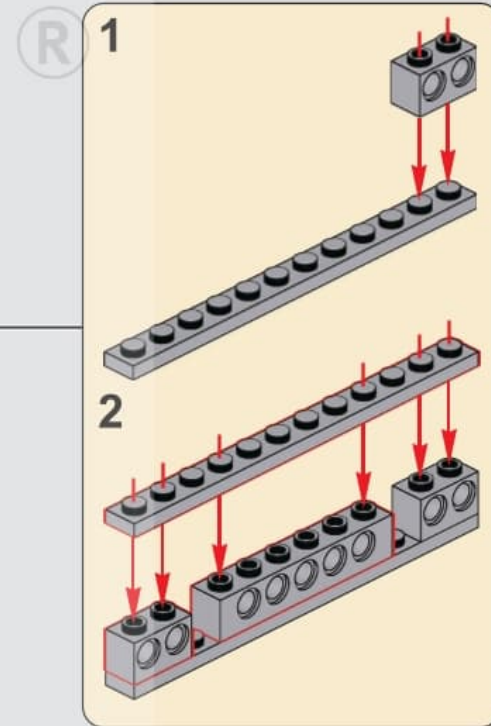
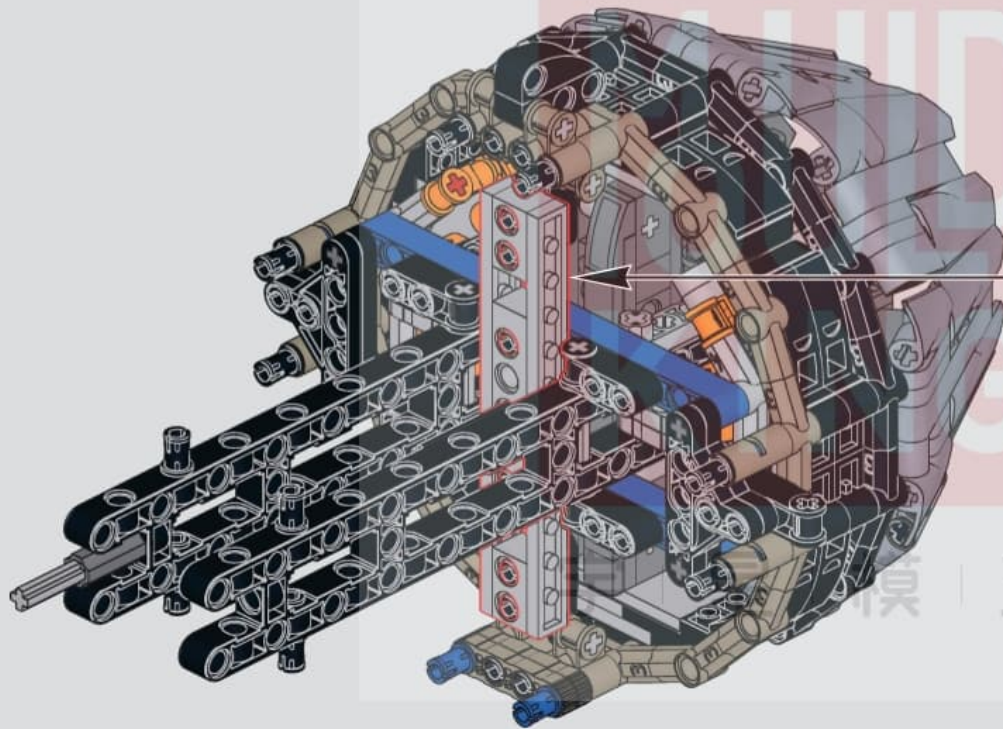





91

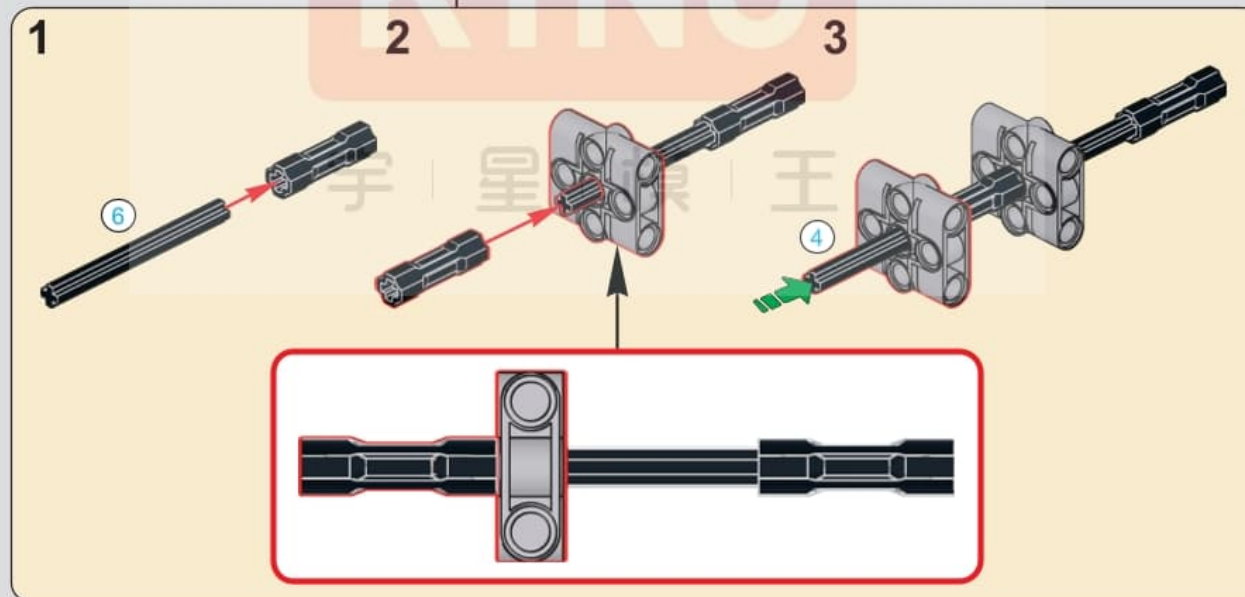
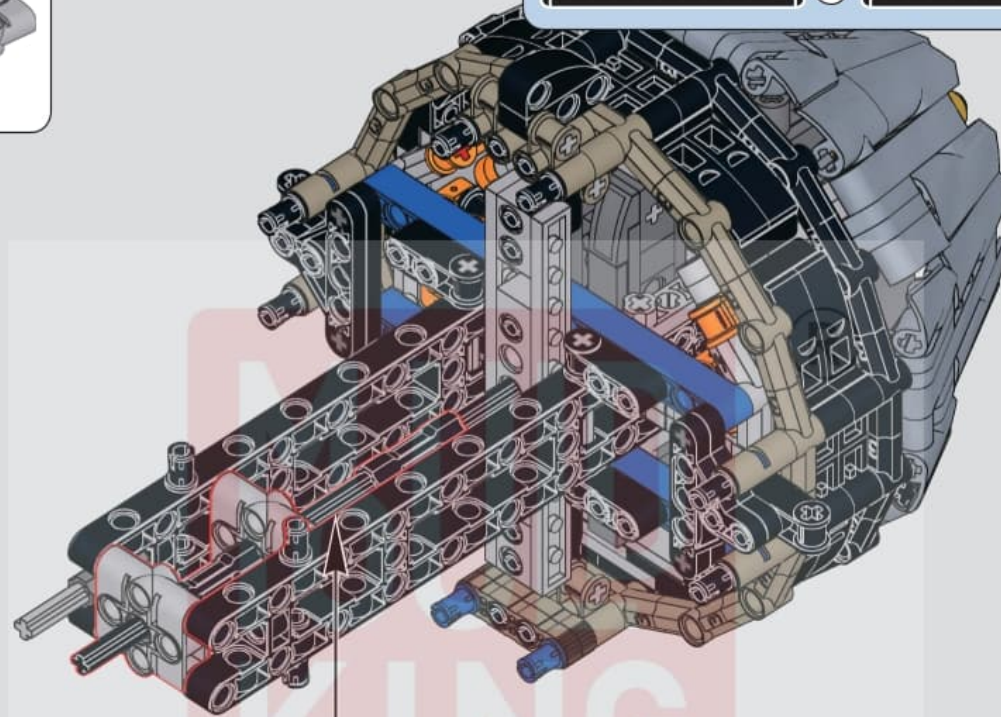

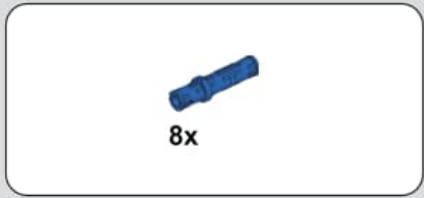

92

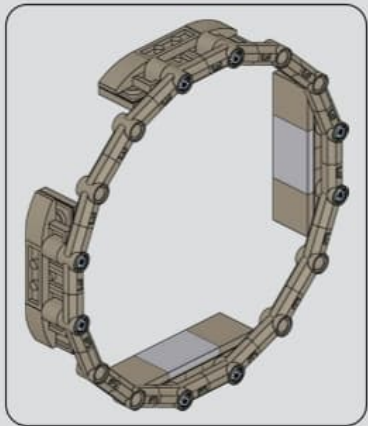
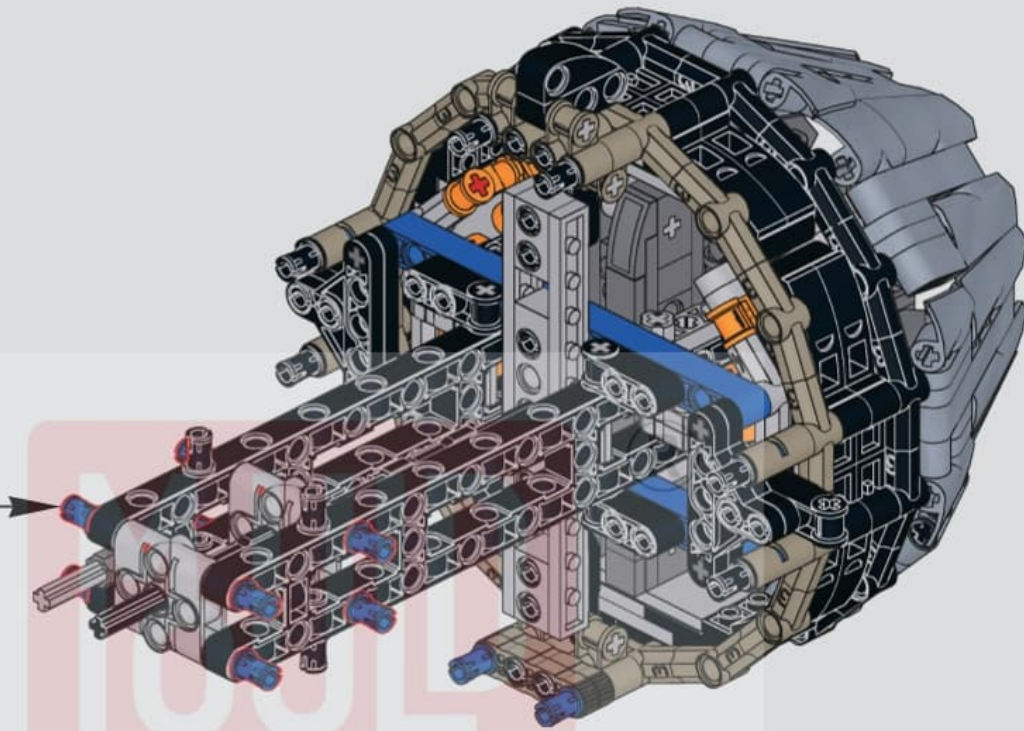
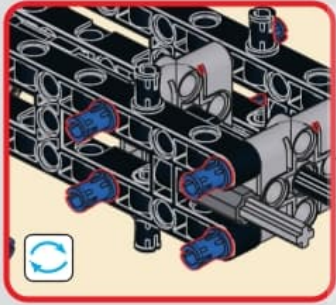

93

宇 | 星 | 模 | 王

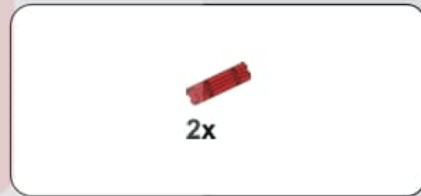

94

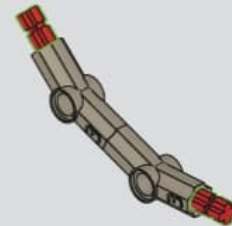
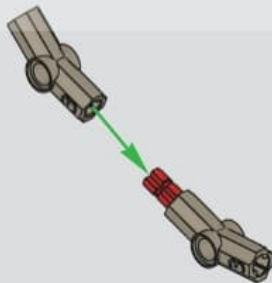
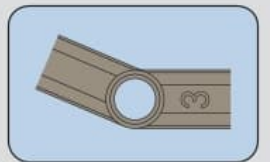

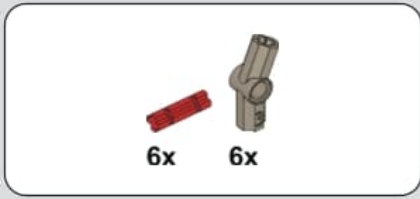

95

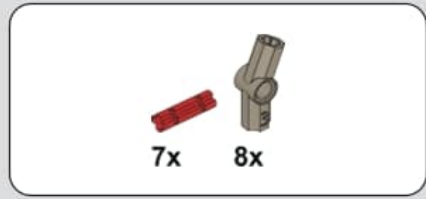
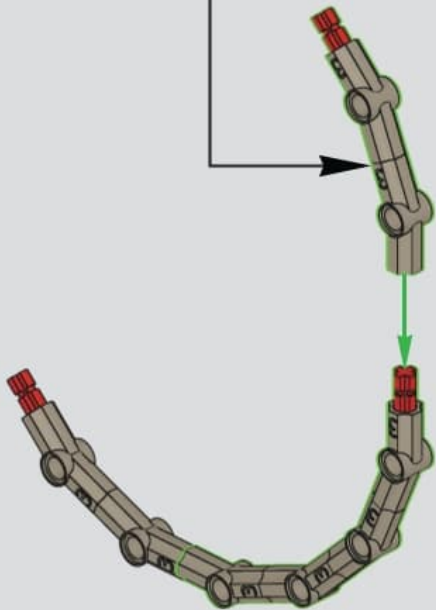
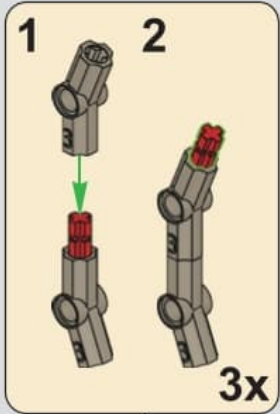

96

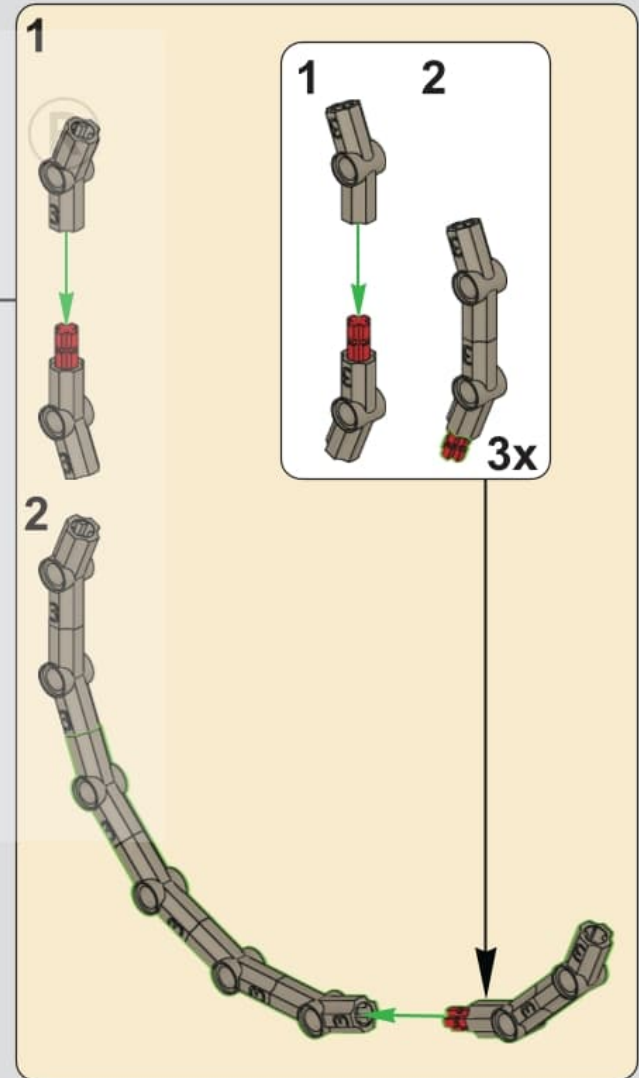
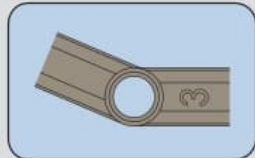
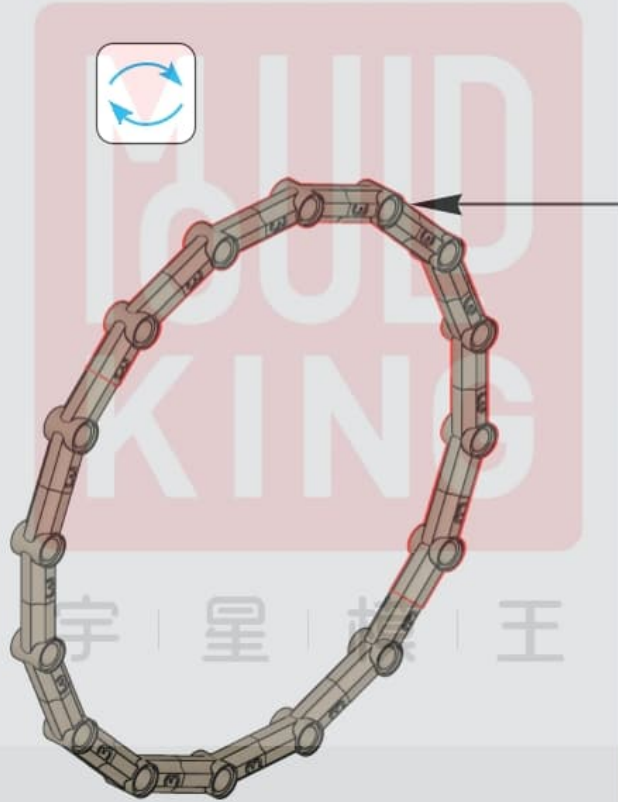



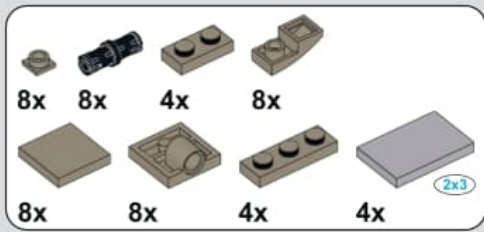

97

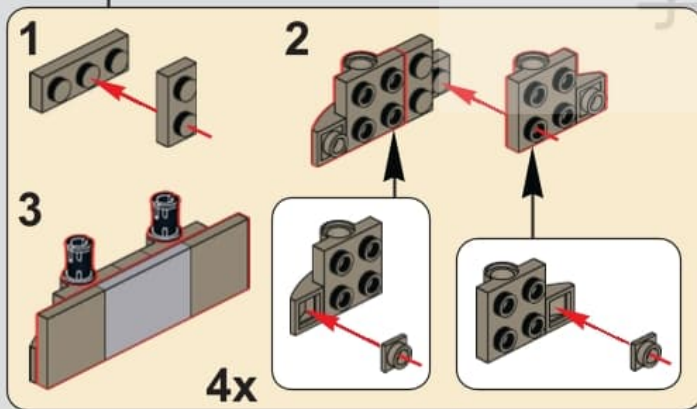
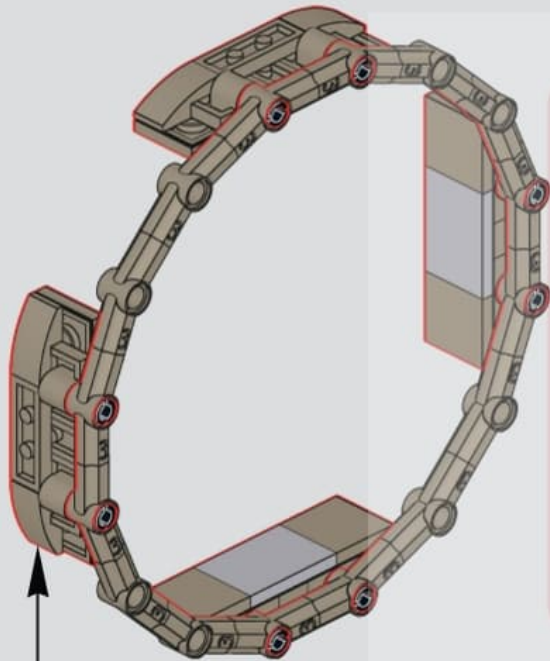

98

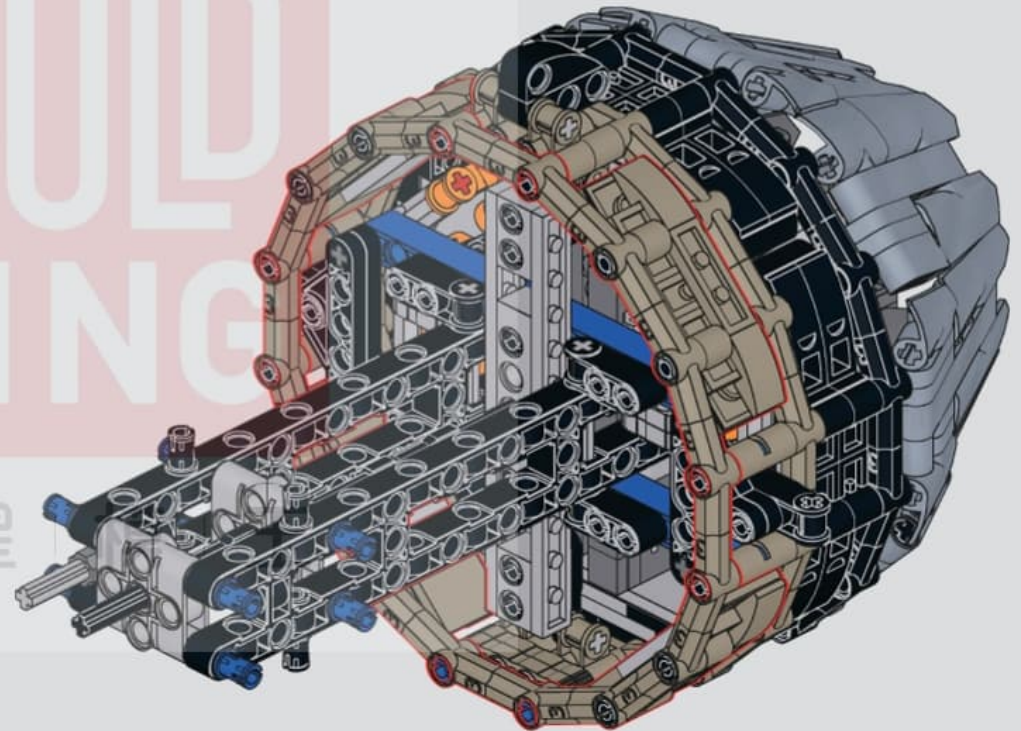

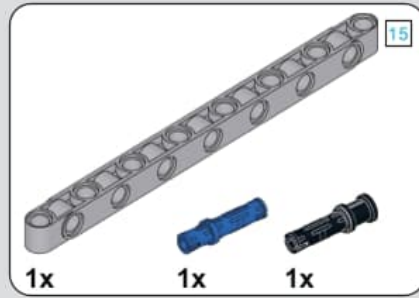
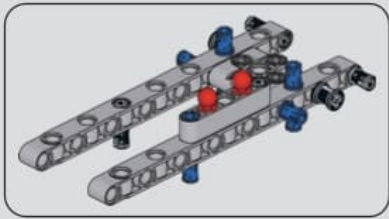

100

99

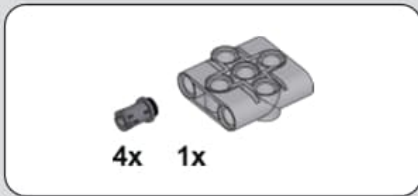
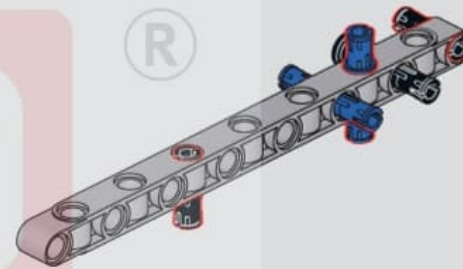
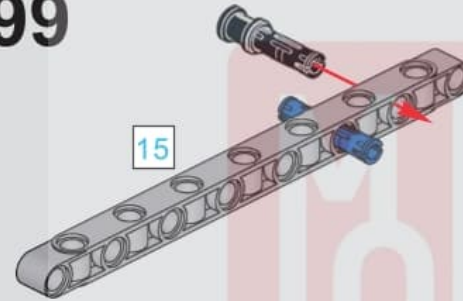

101

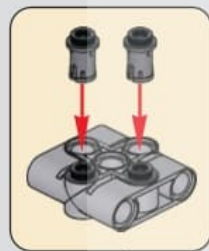

102

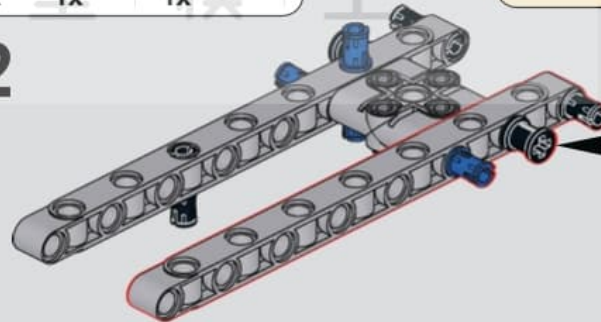
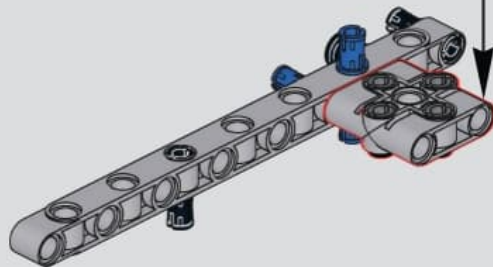
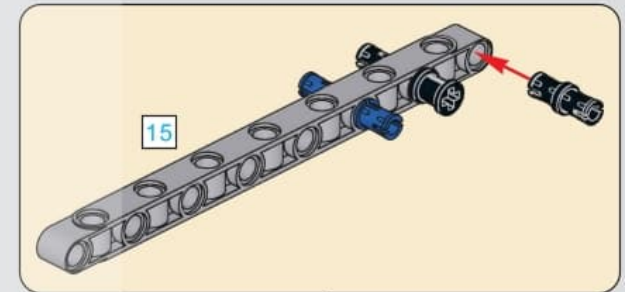



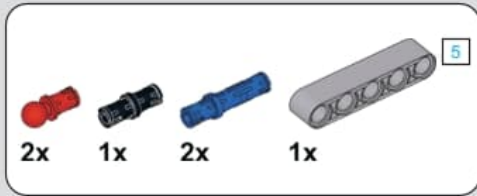

103

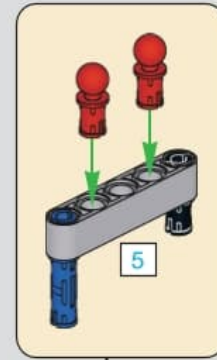
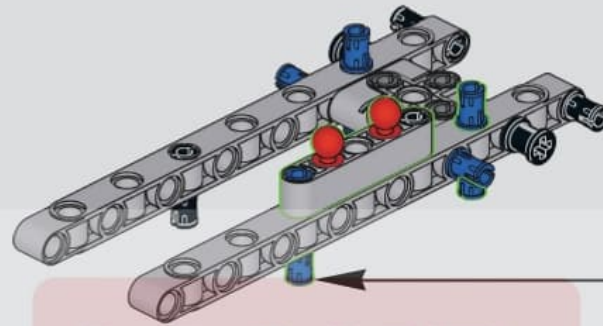

(R)

104

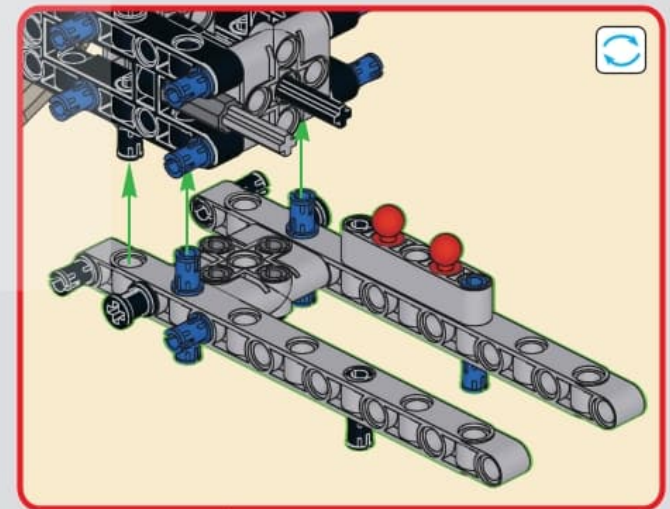
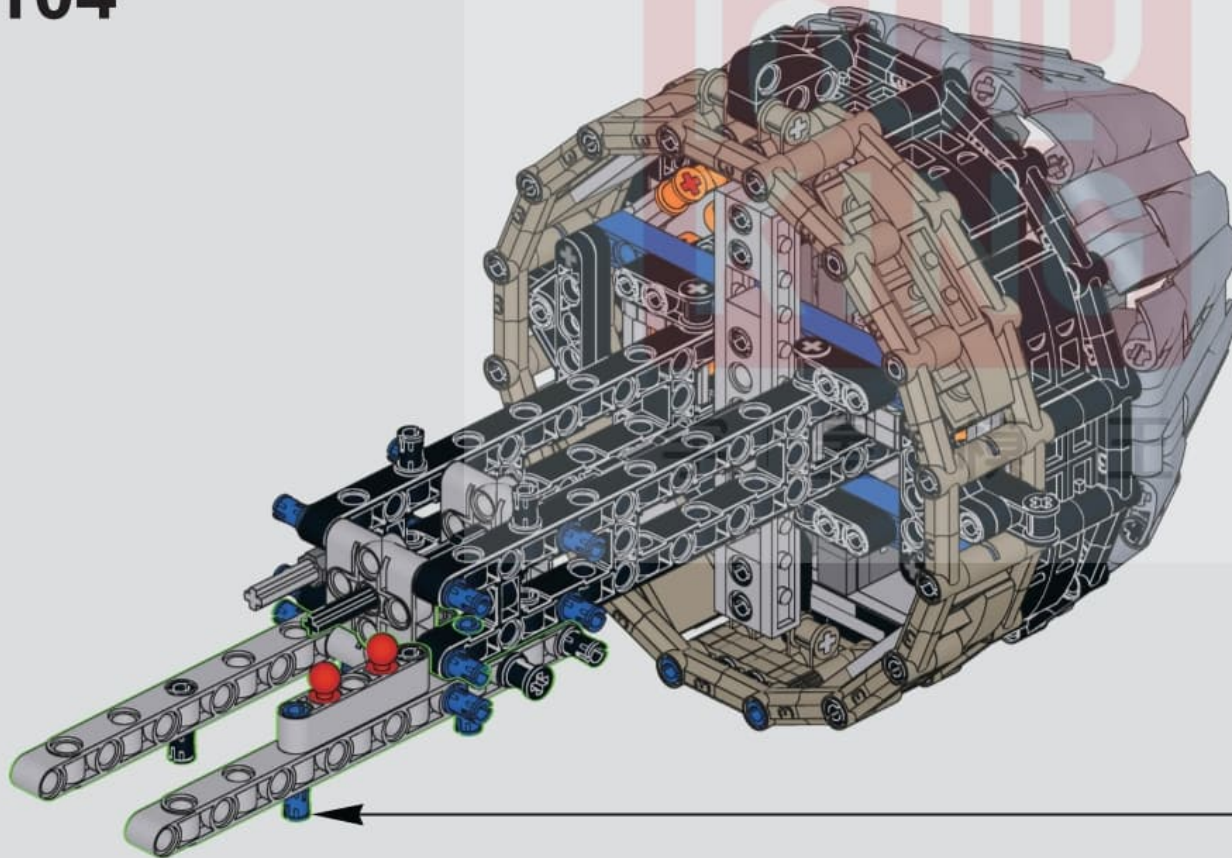



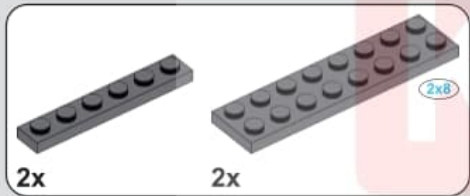
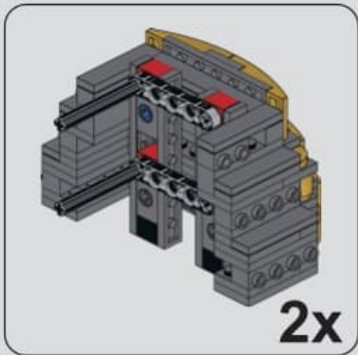
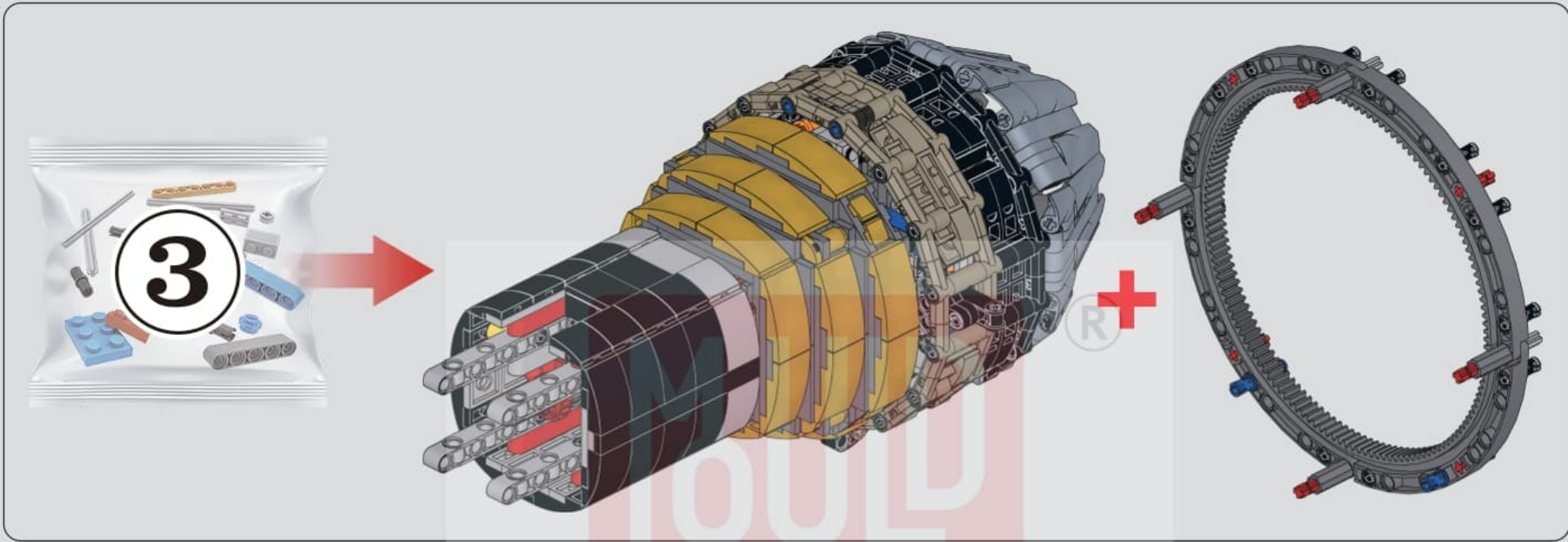

105



106

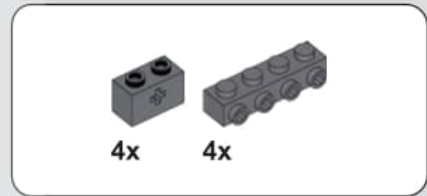

107

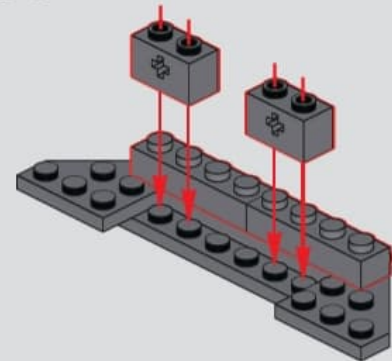
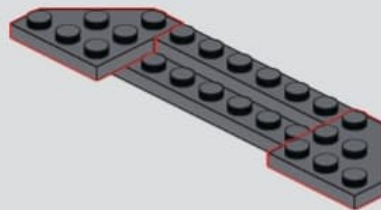
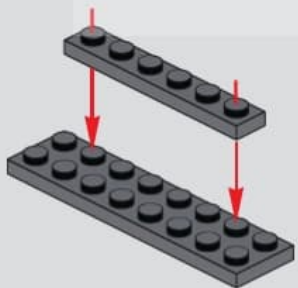

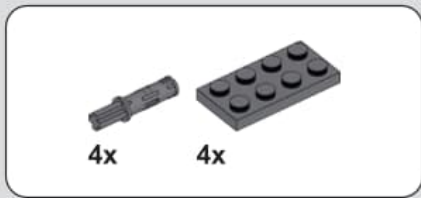

108

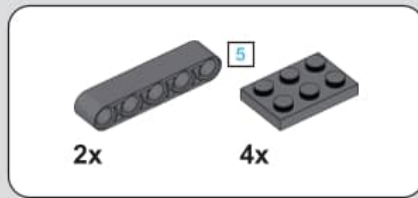
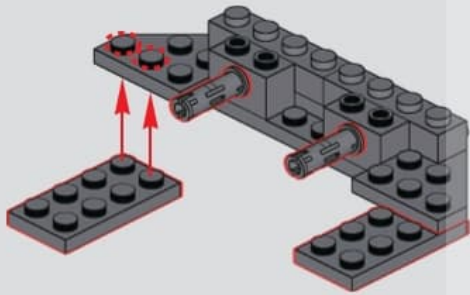

109

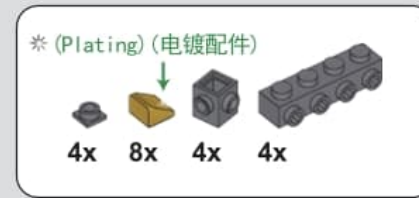
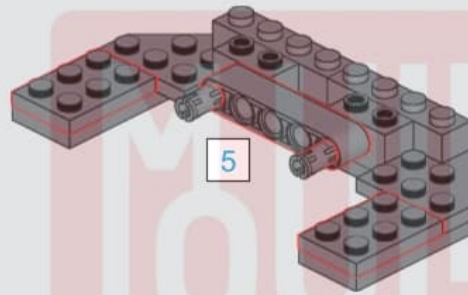

110

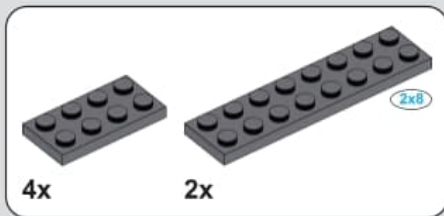
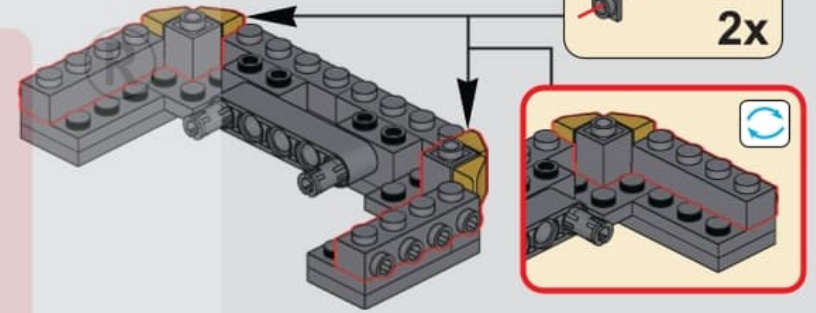

111

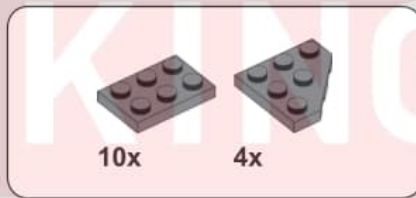
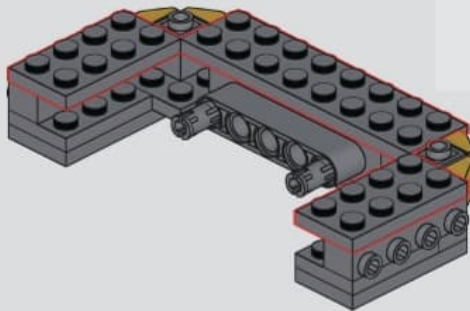

112

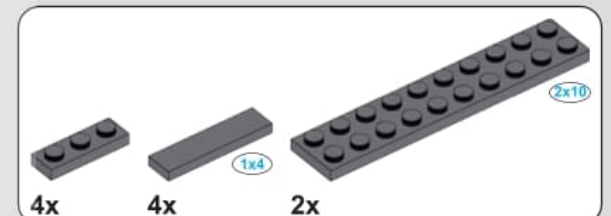
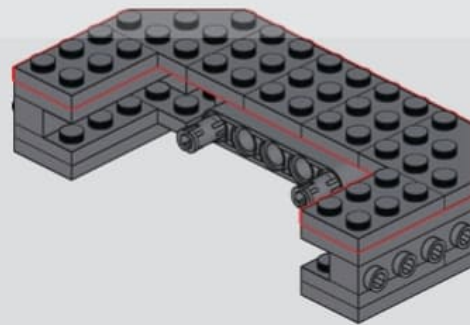

113

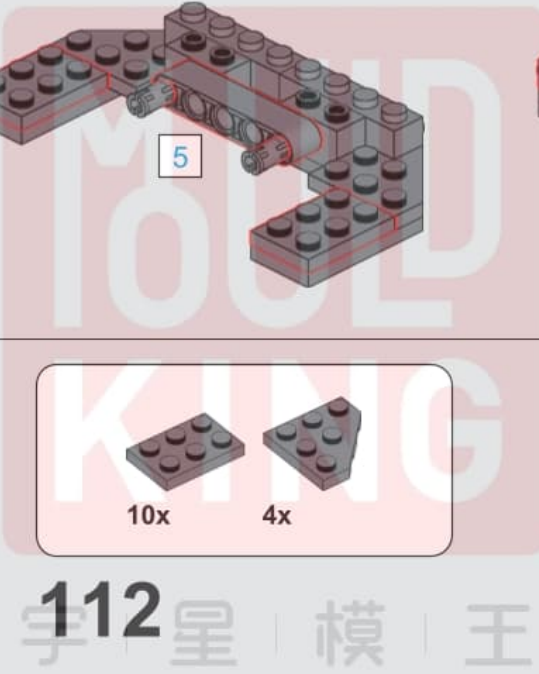
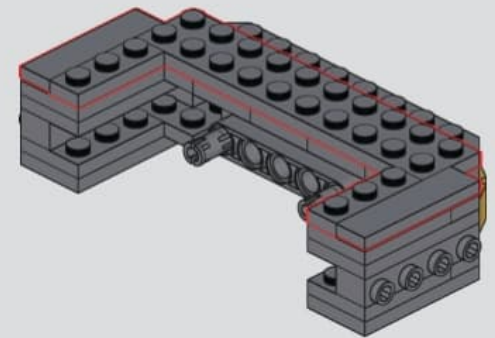

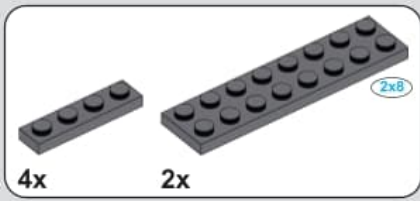

114

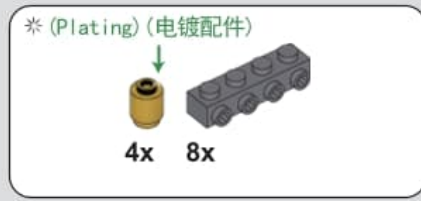
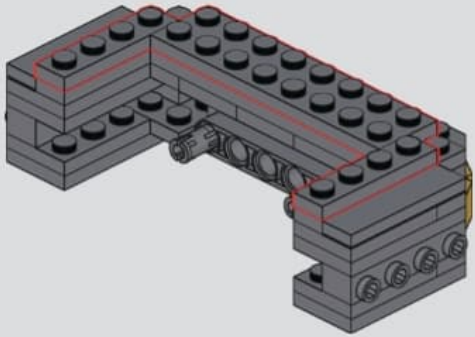

115

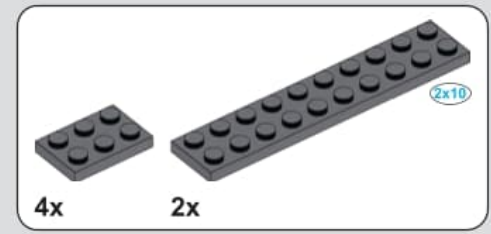
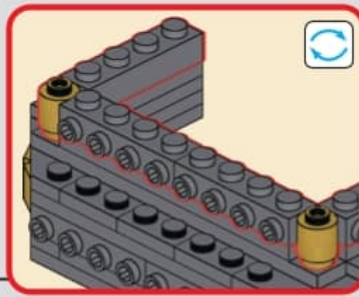
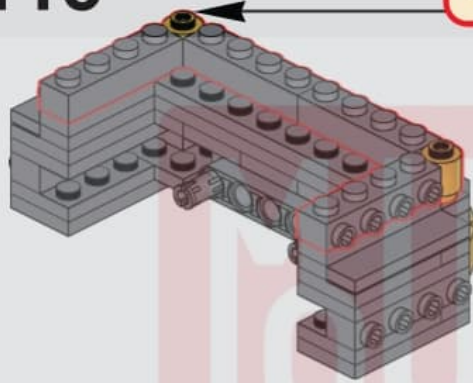

116

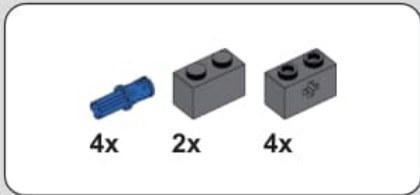
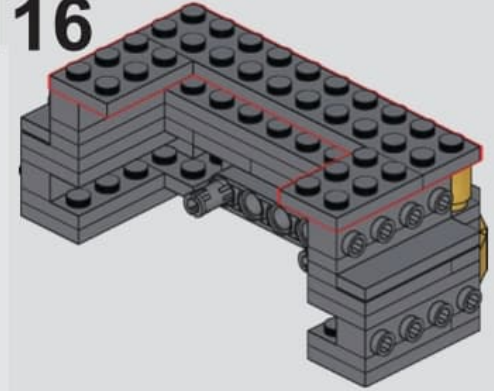

117

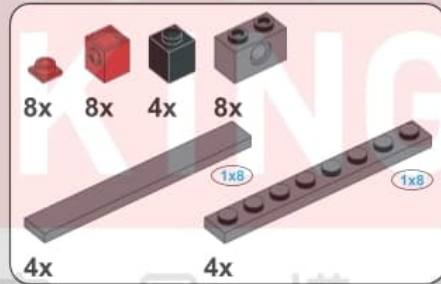
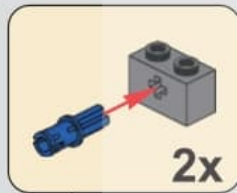
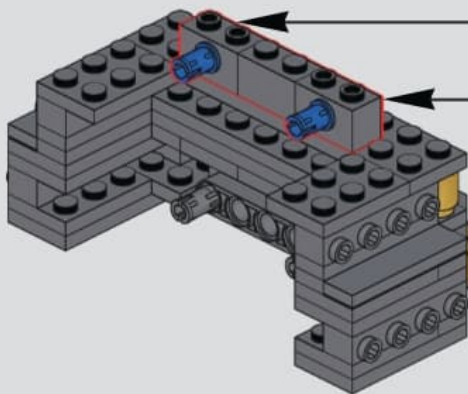

118

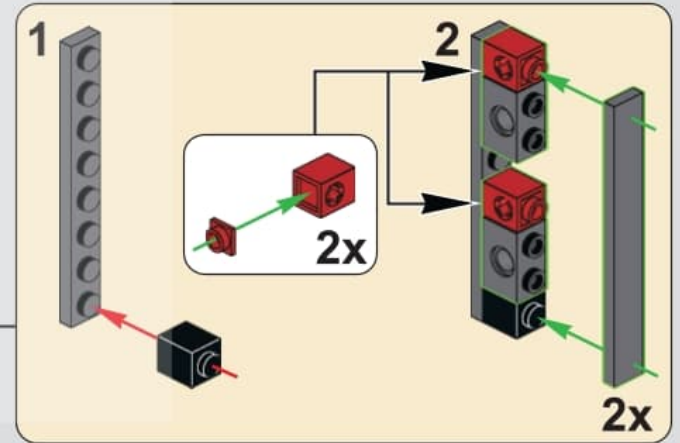
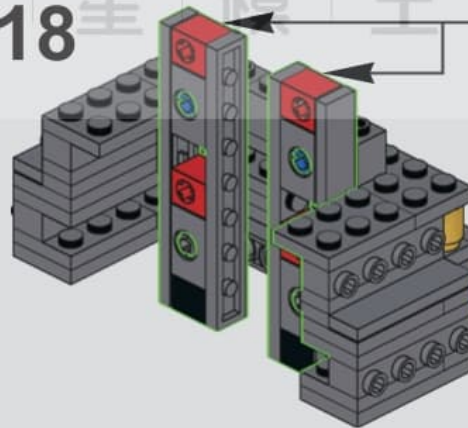



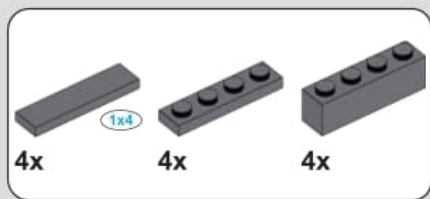

119

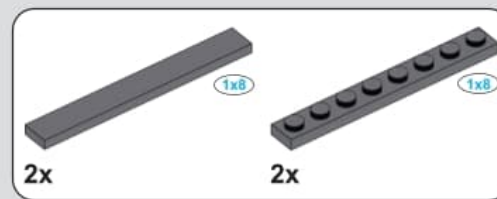
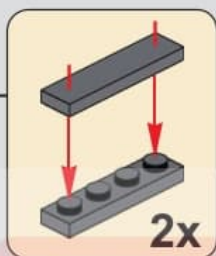
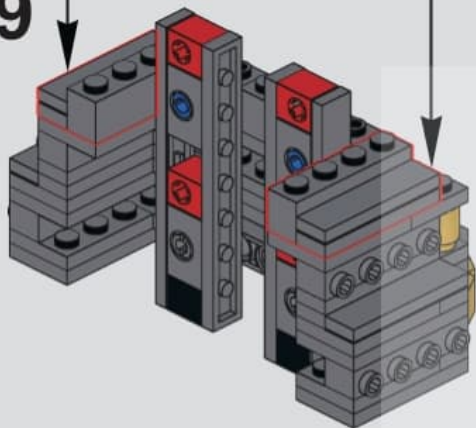

120

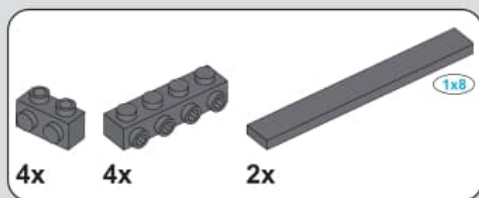
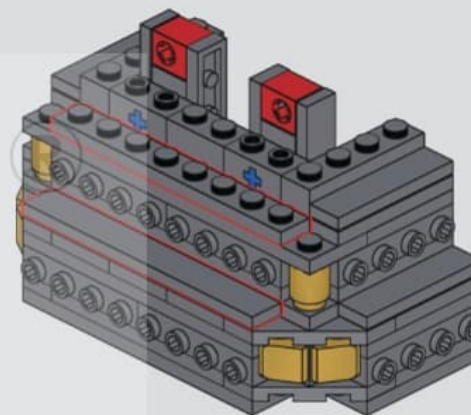

121

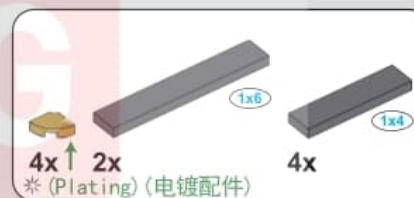
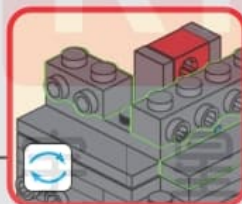
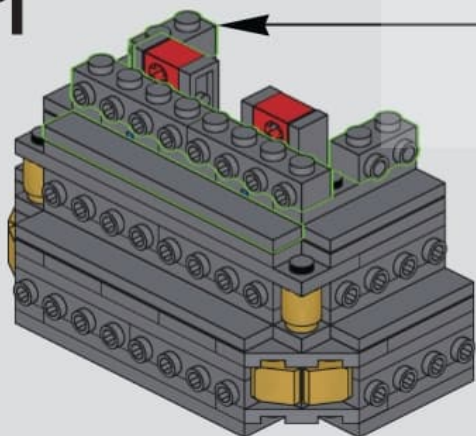

122

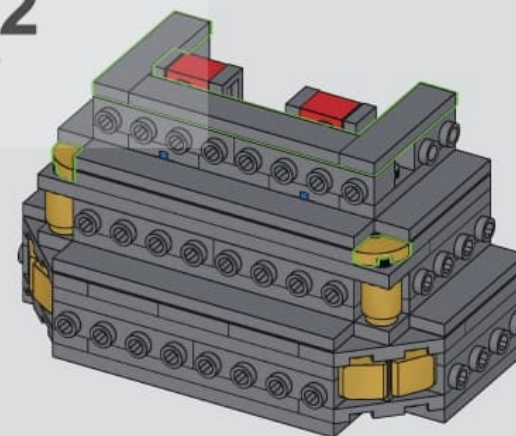

模 工

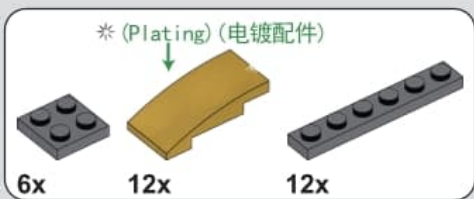

123

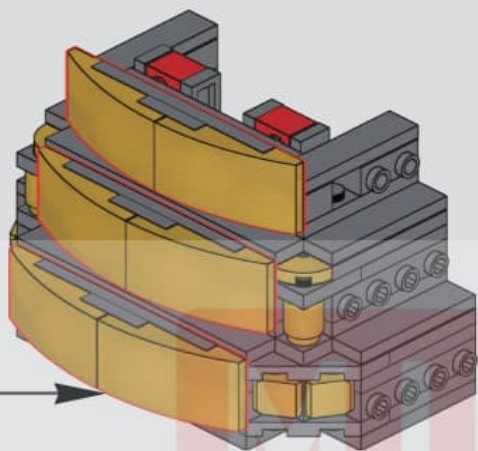
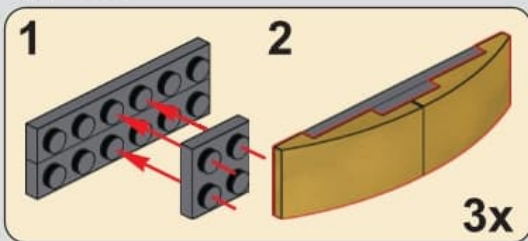

124

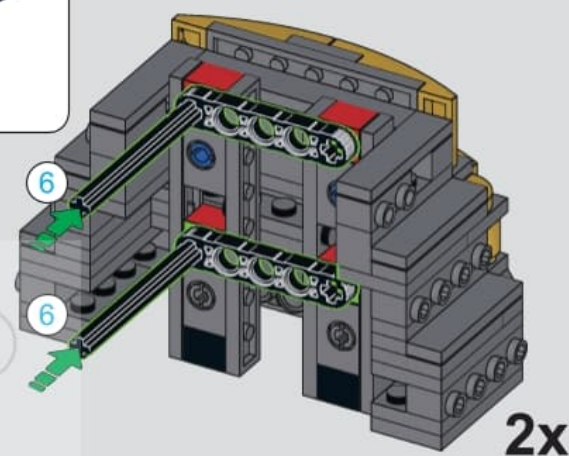

125

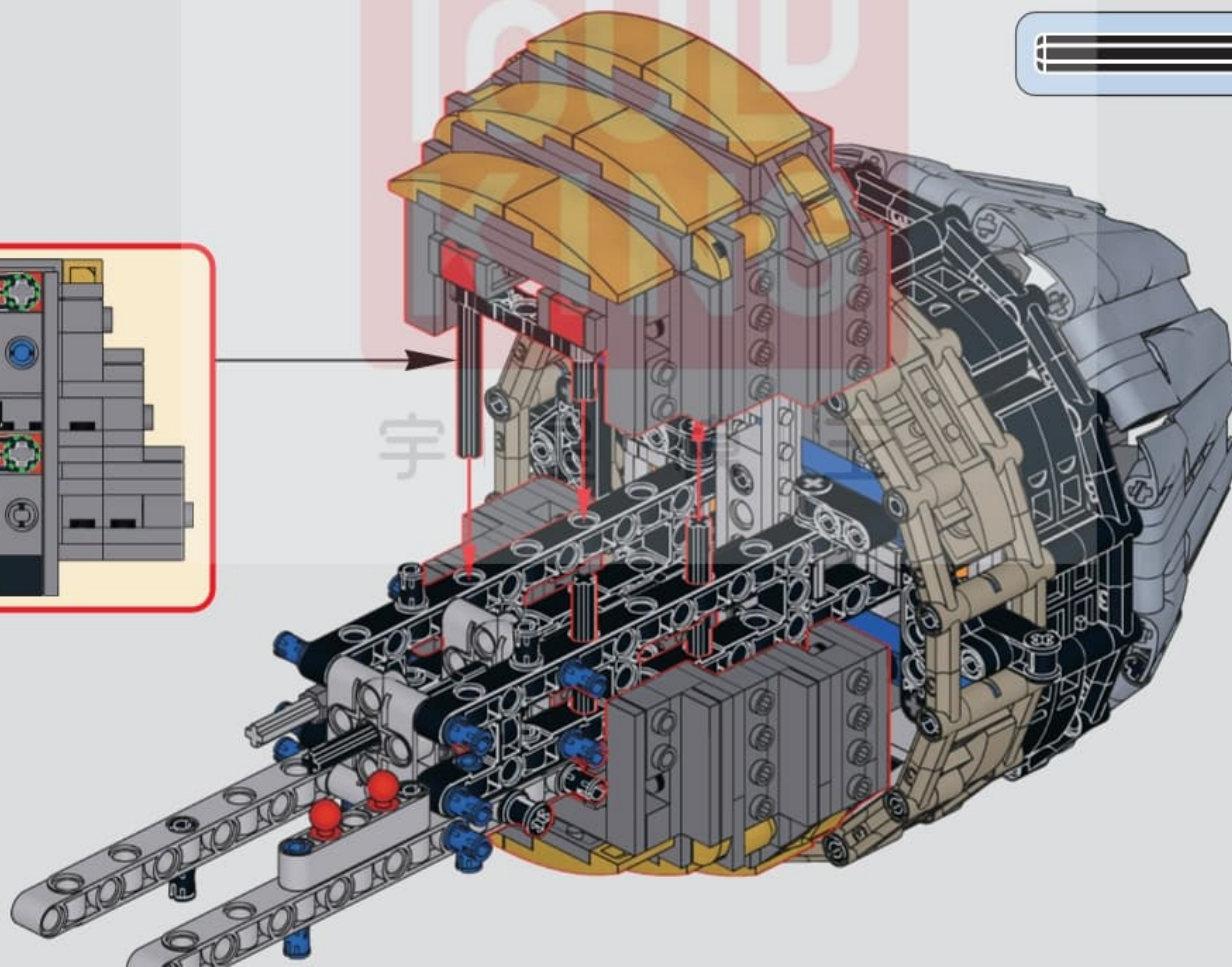
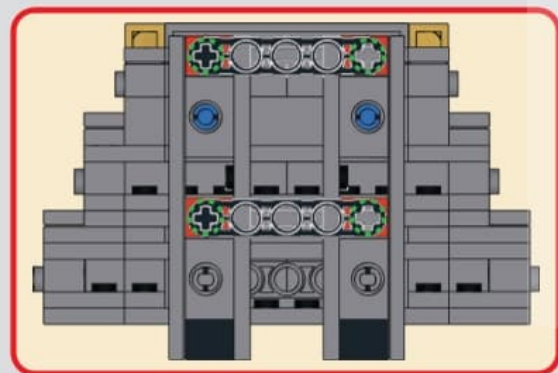



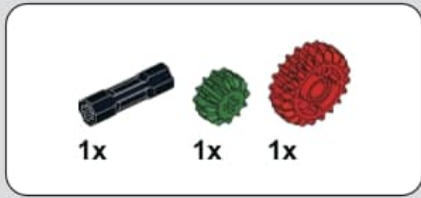

126

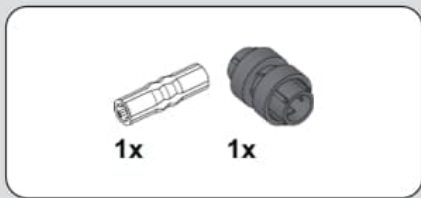
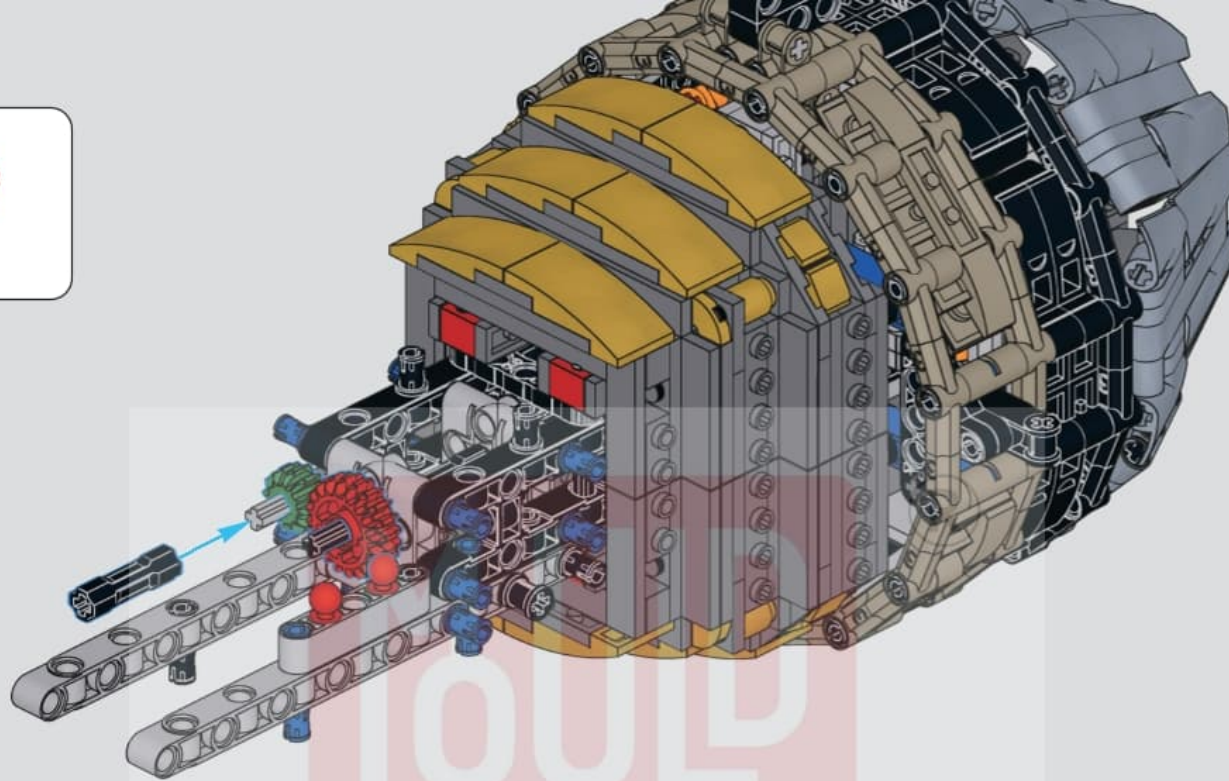

127

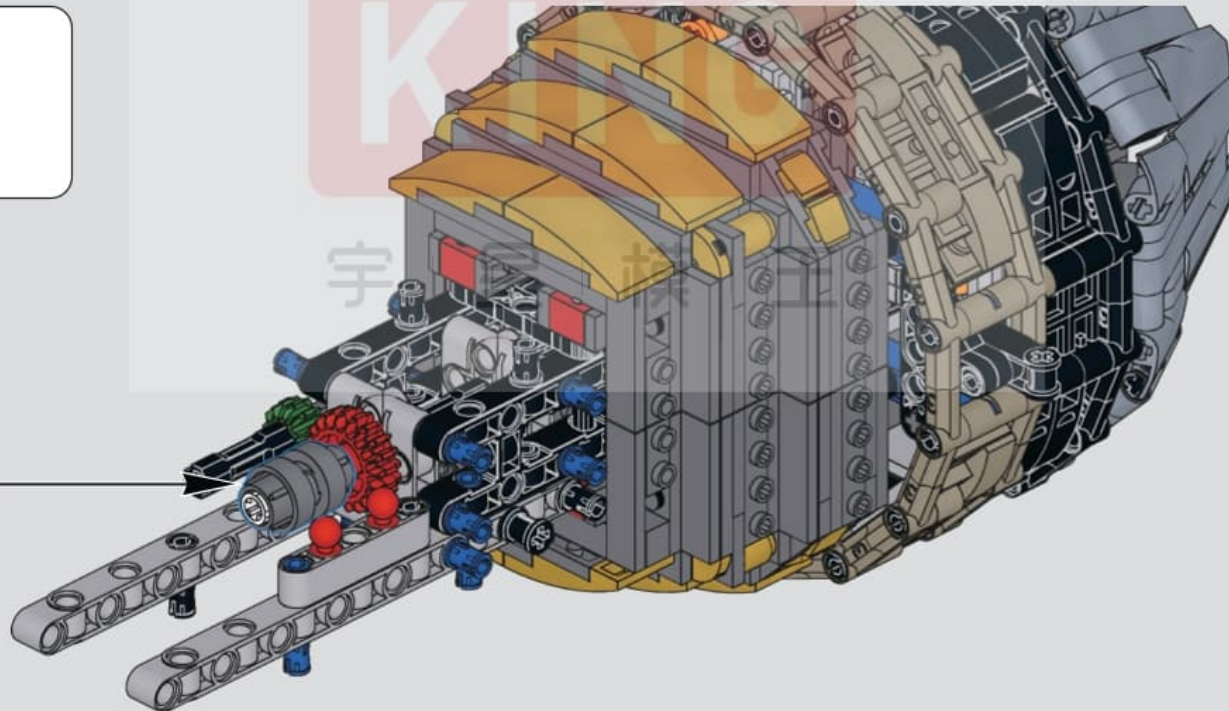
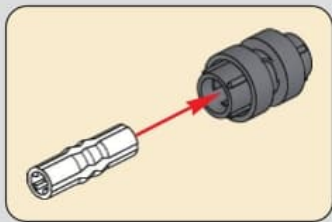



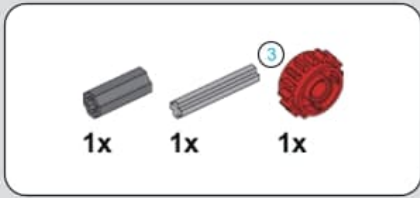

128

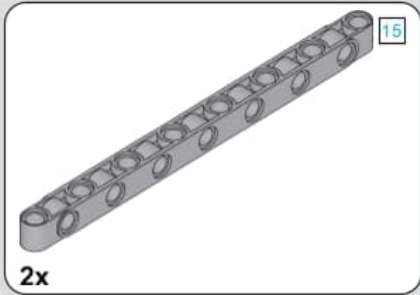
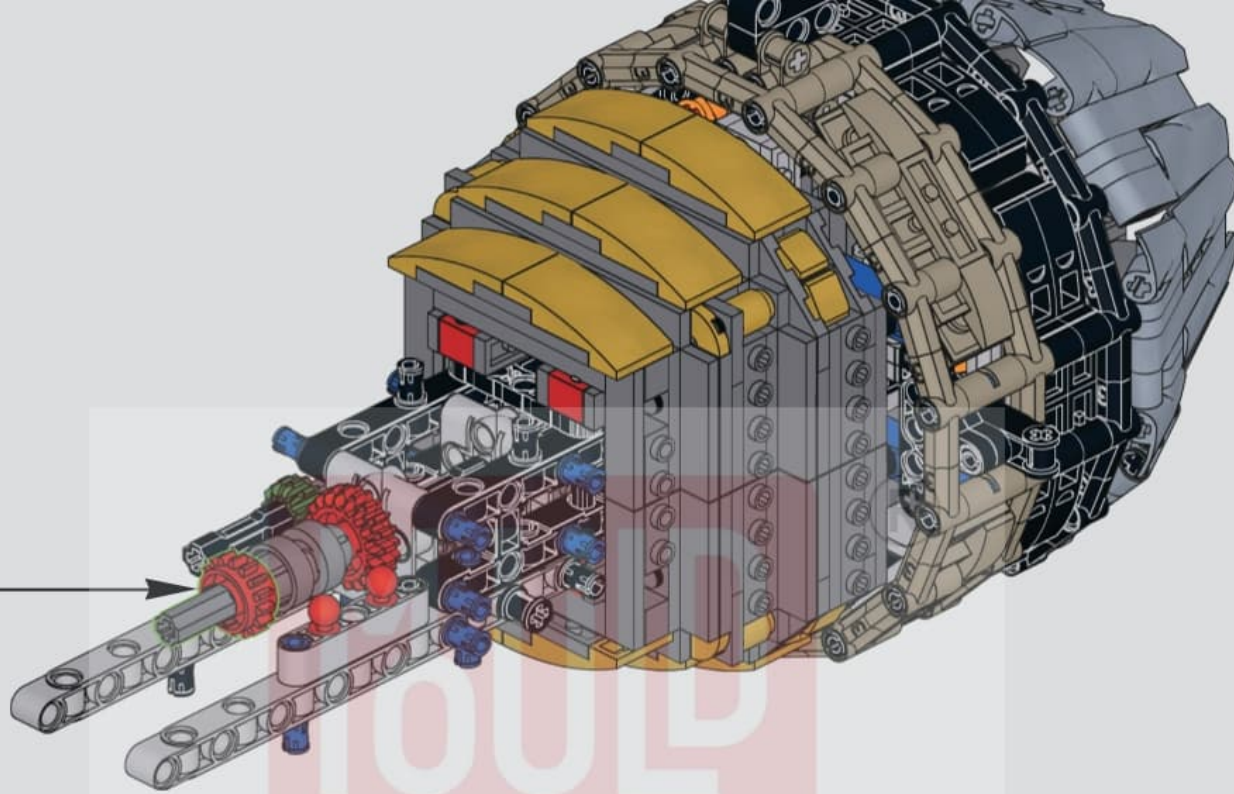
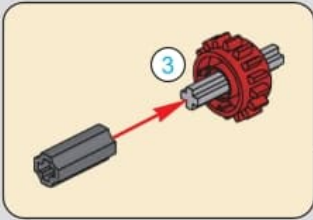

129

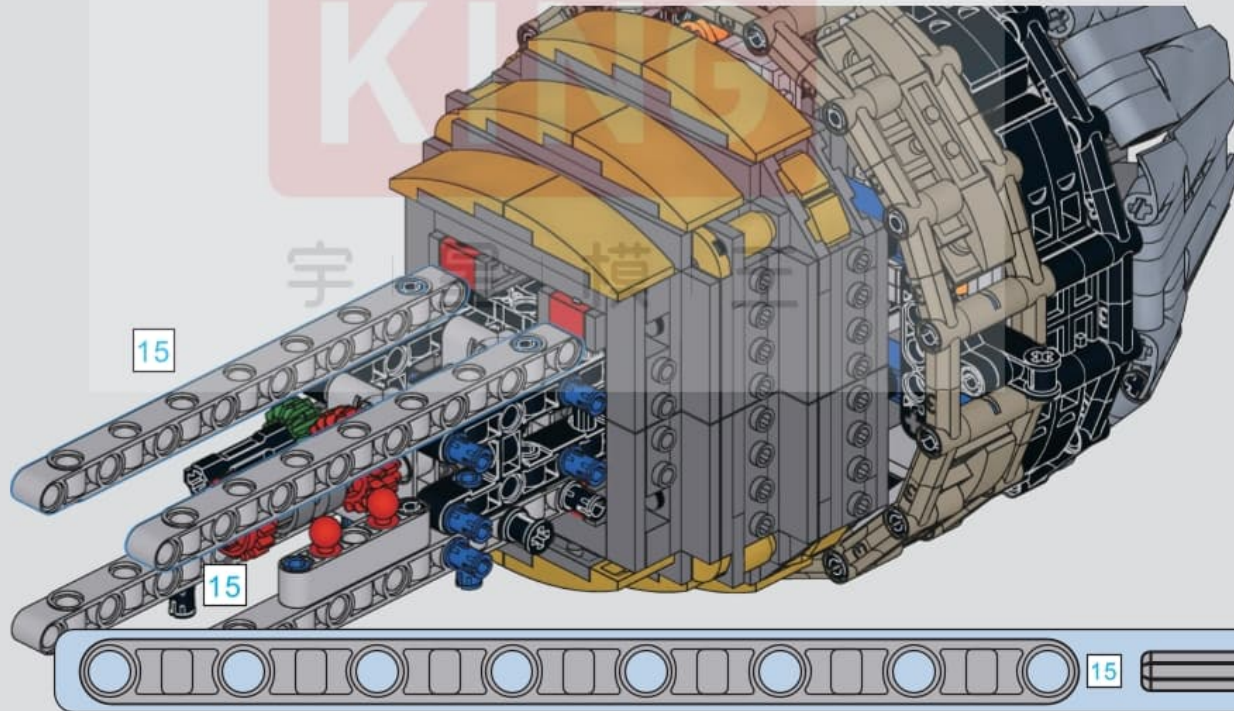





130

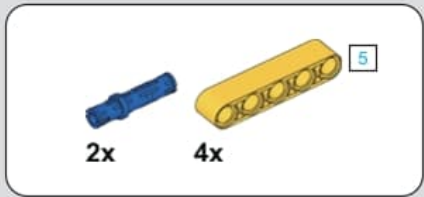
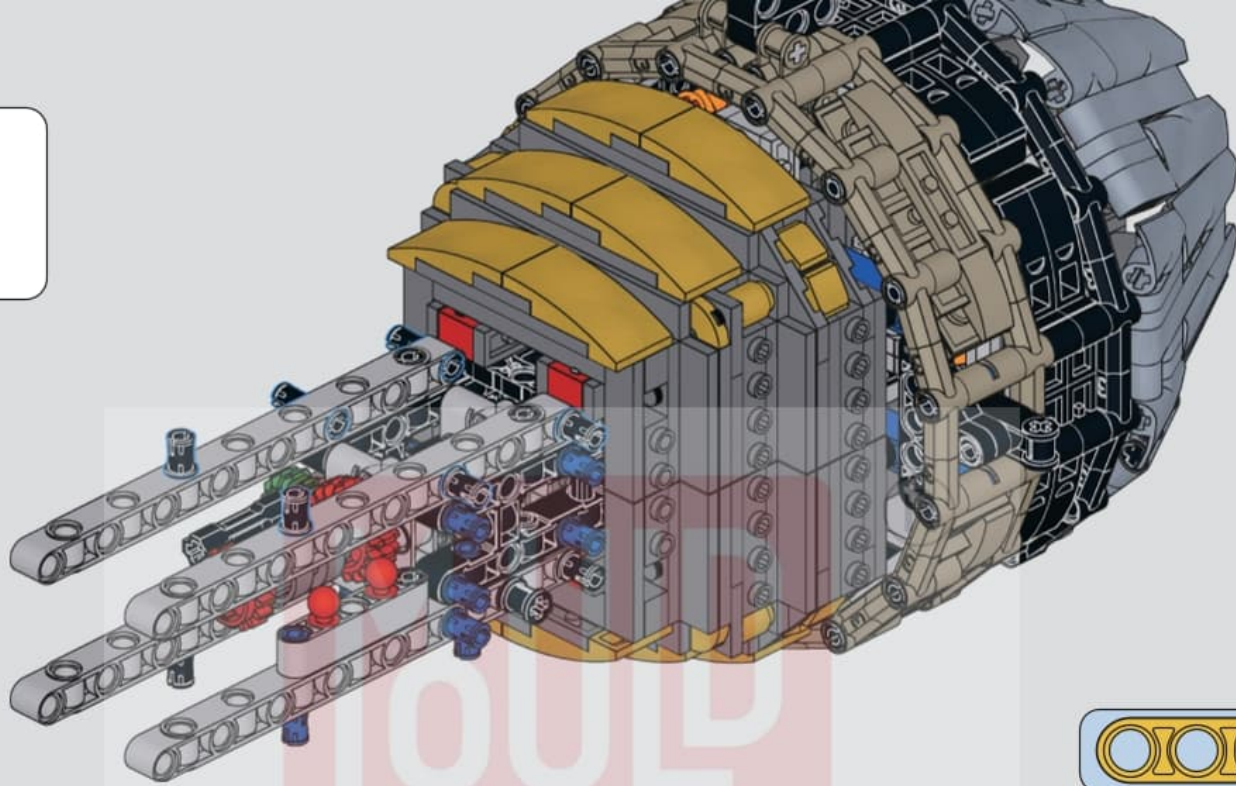

131

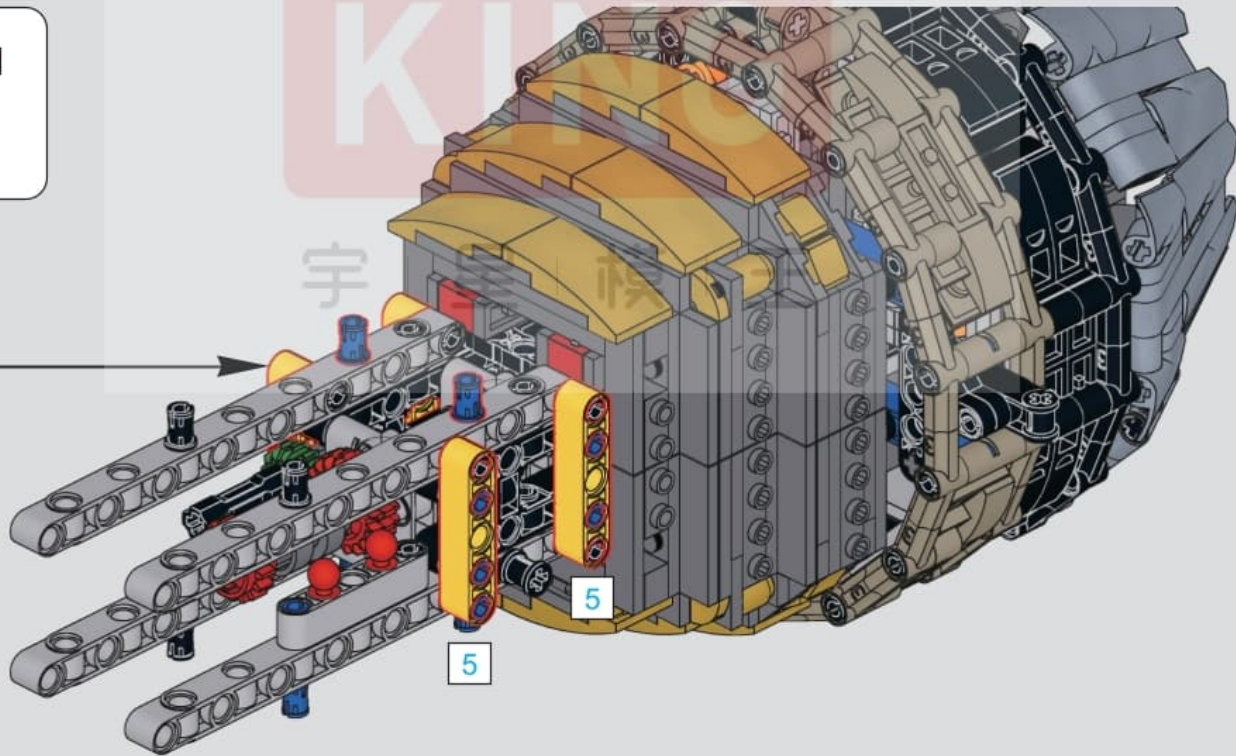
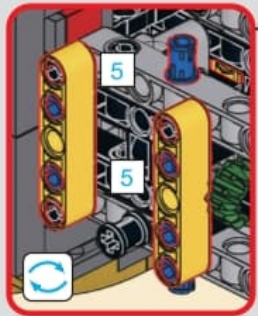



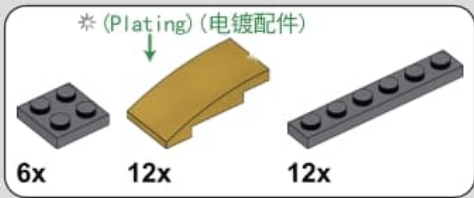

# 132

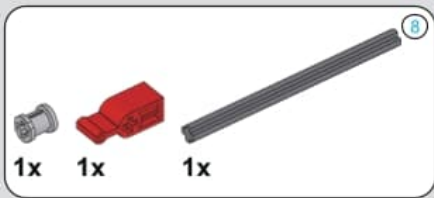
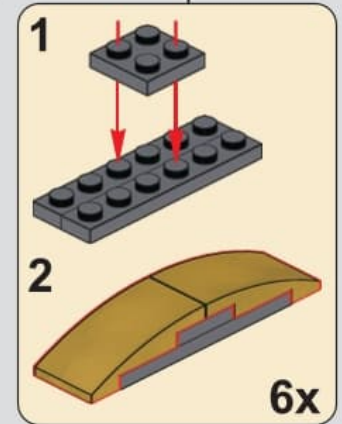
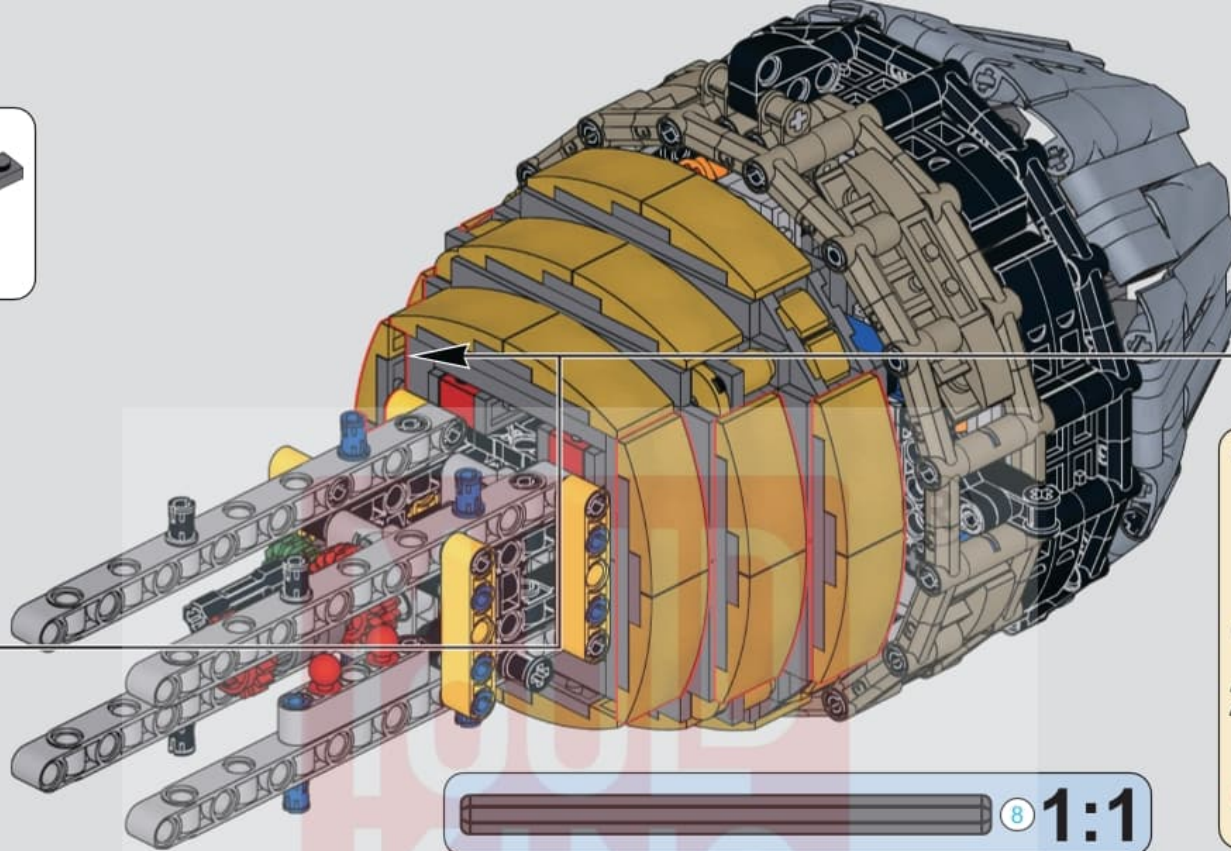
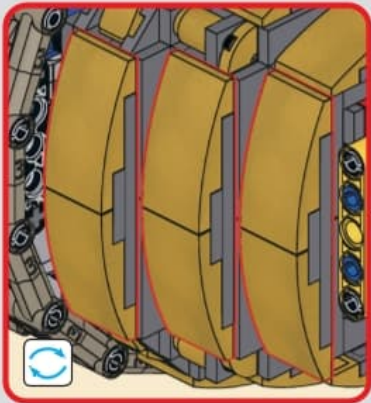

# 133

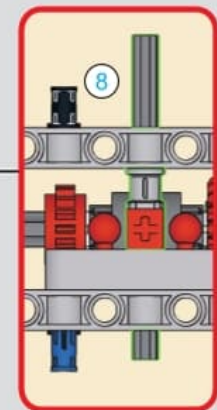
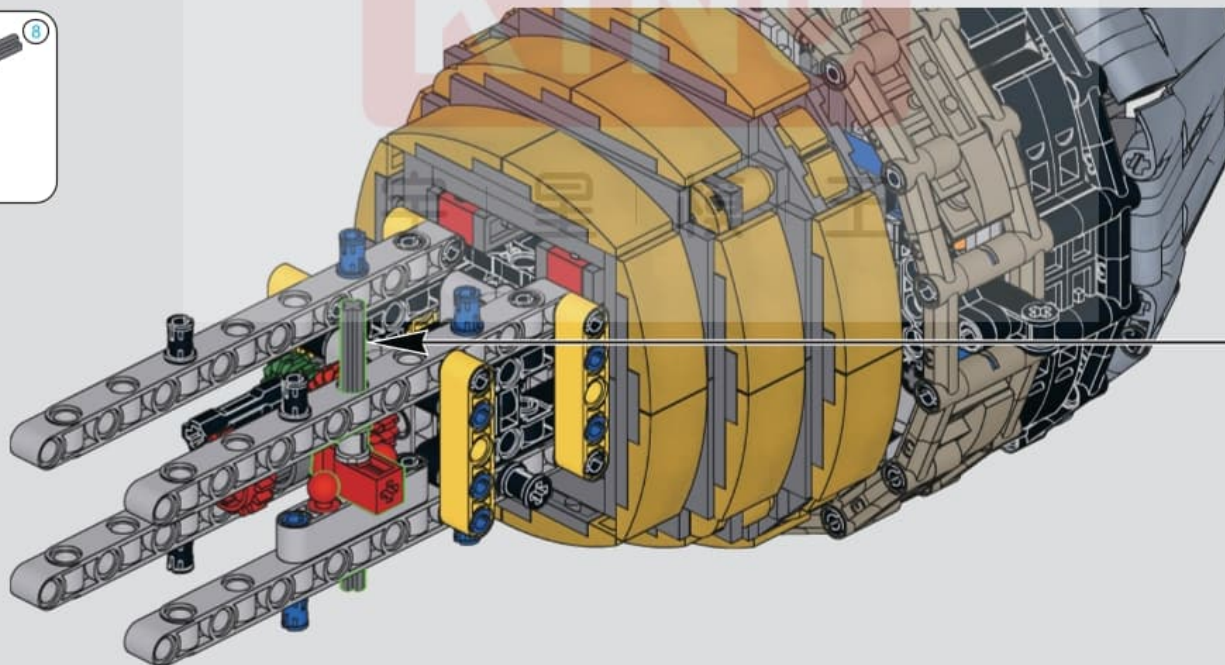



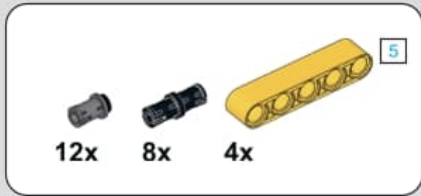

134

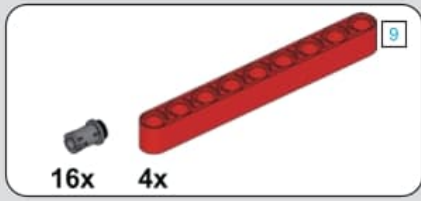
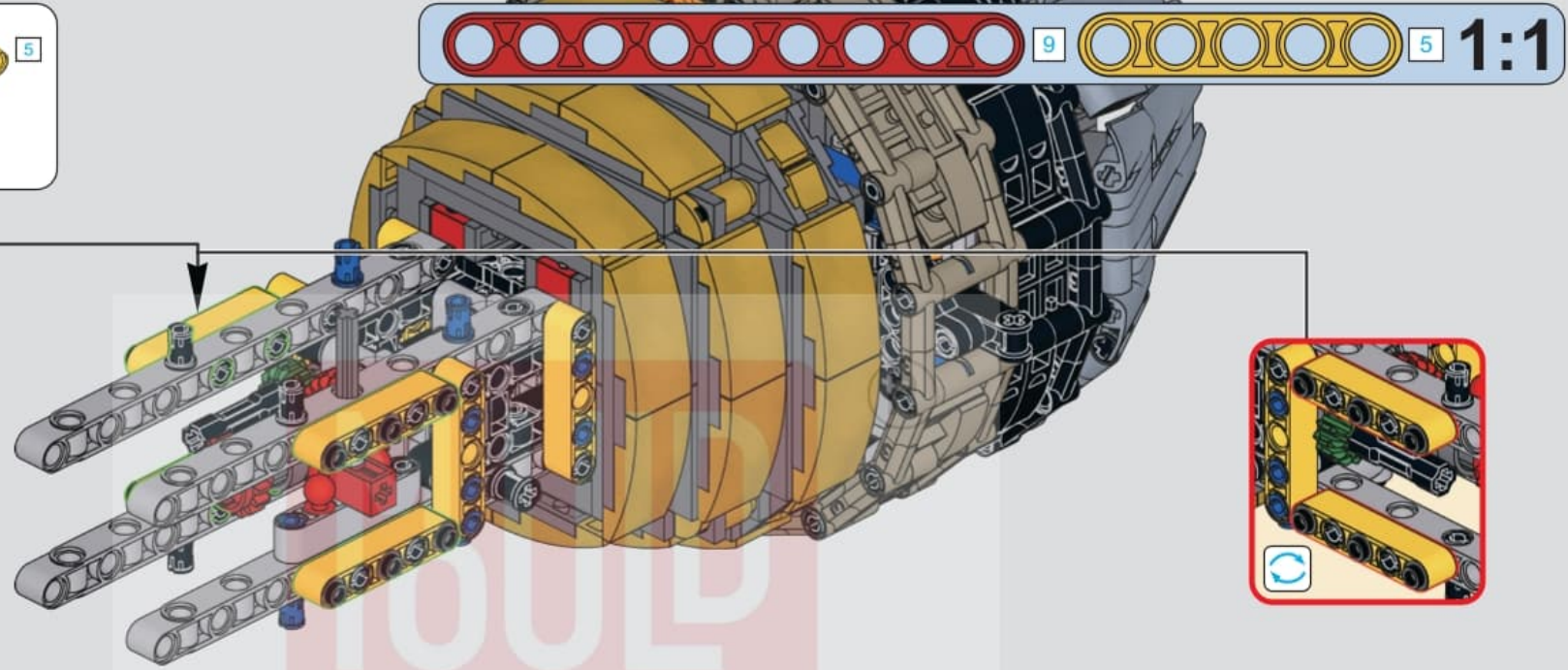
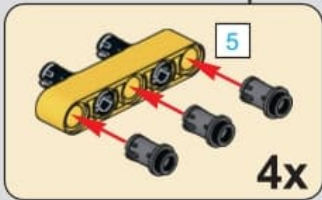

135

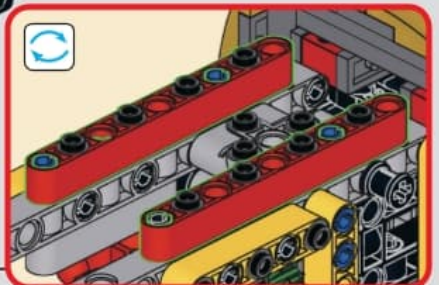
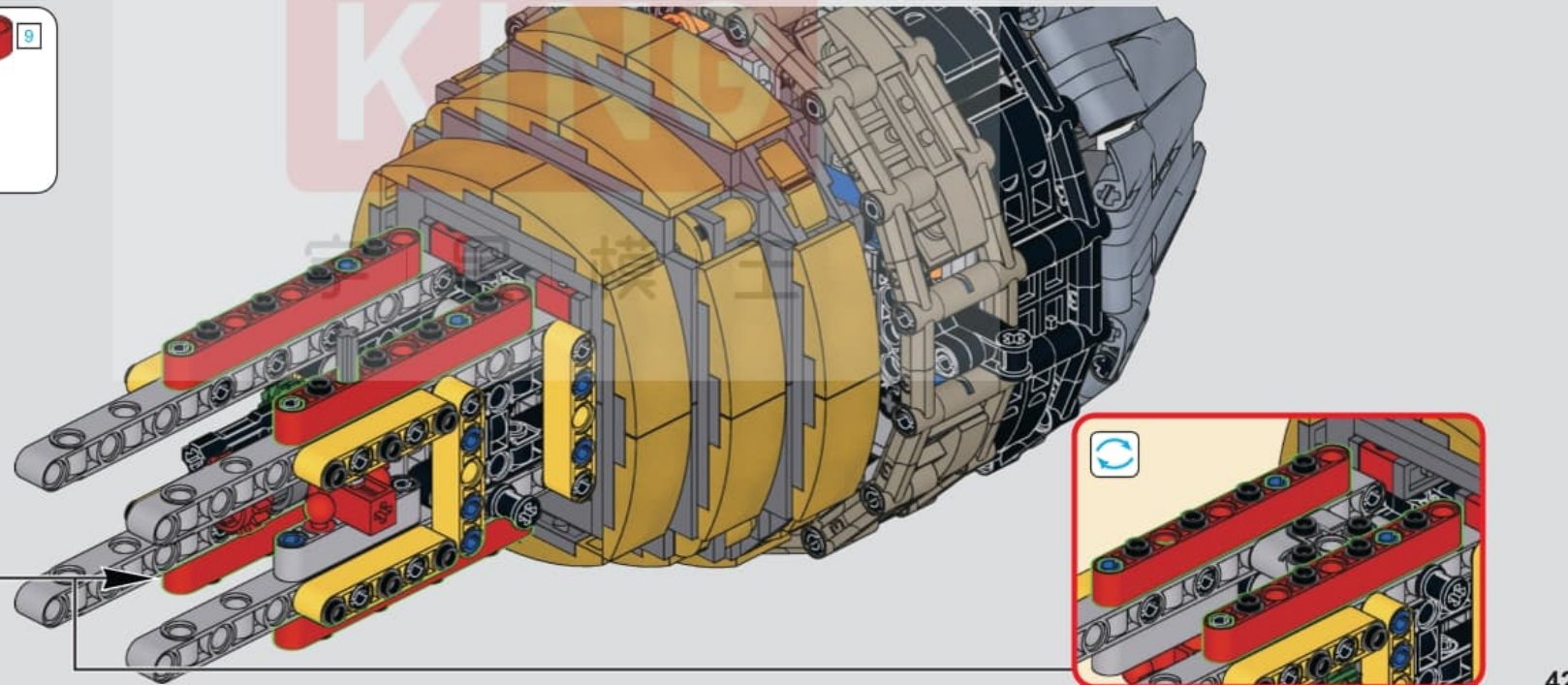
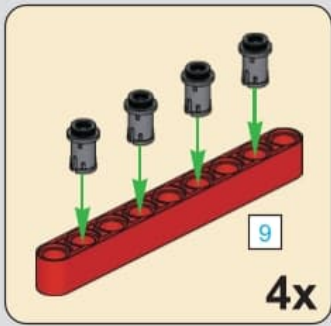



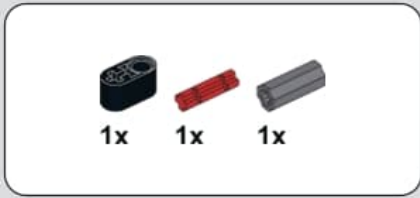

136

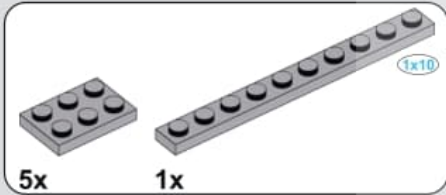
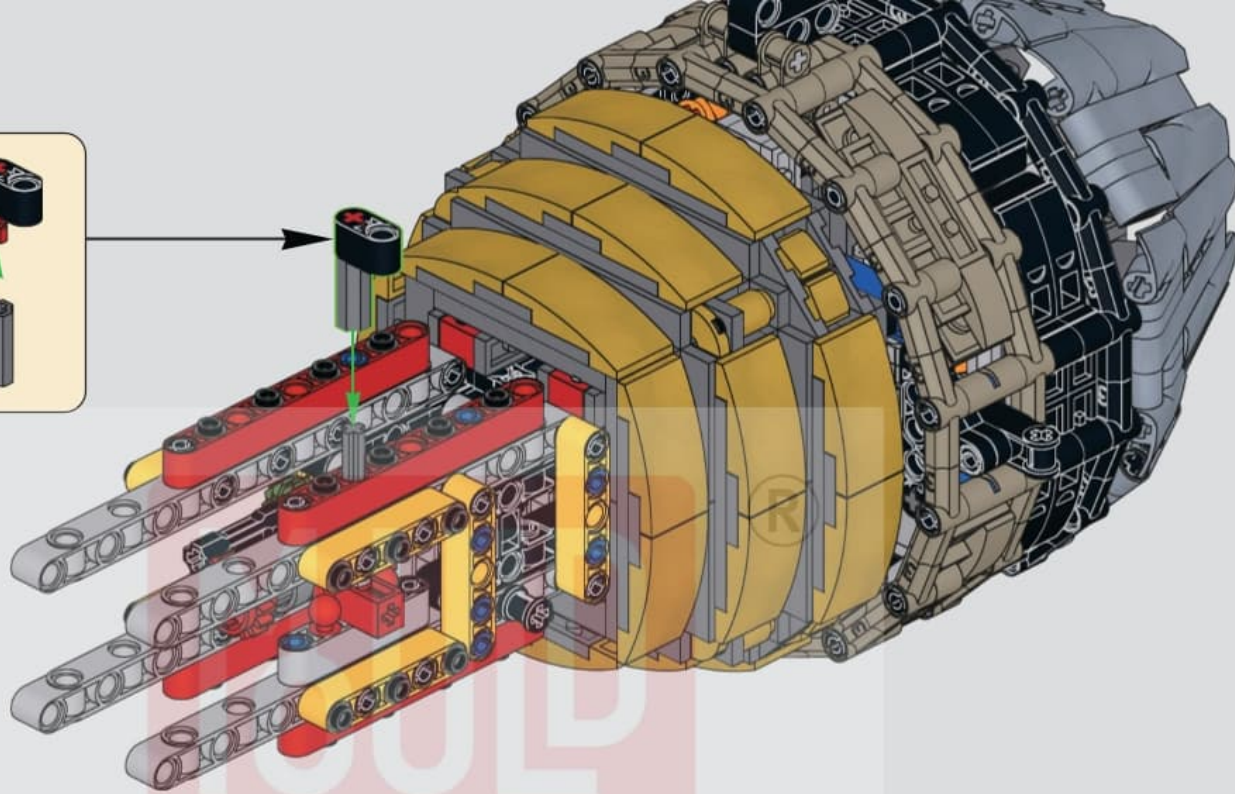
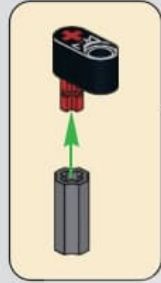

137

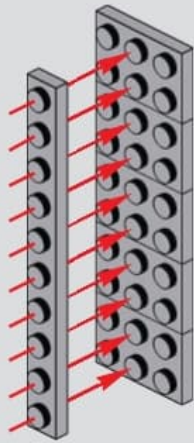

138

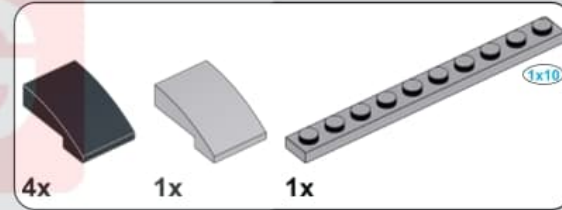
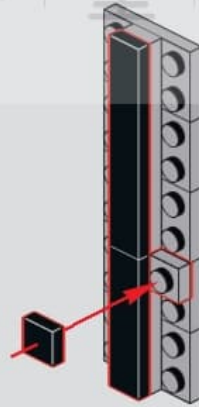

139

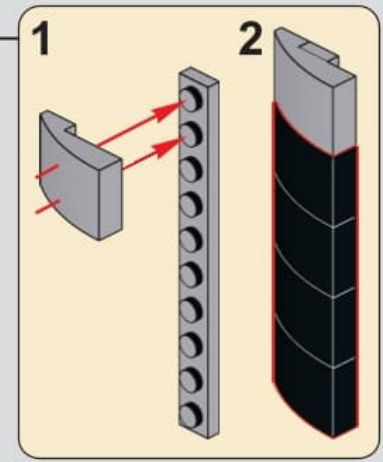

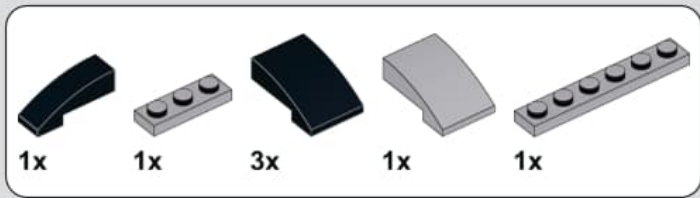

140

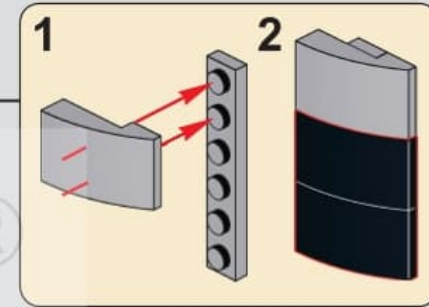
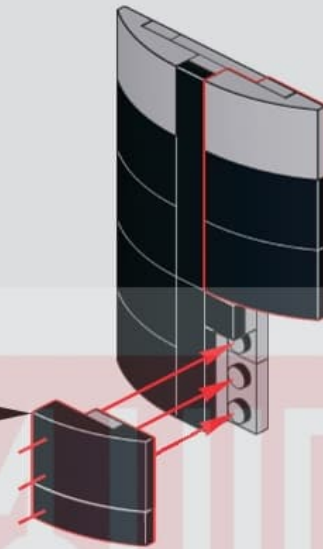
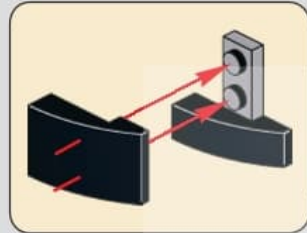

141

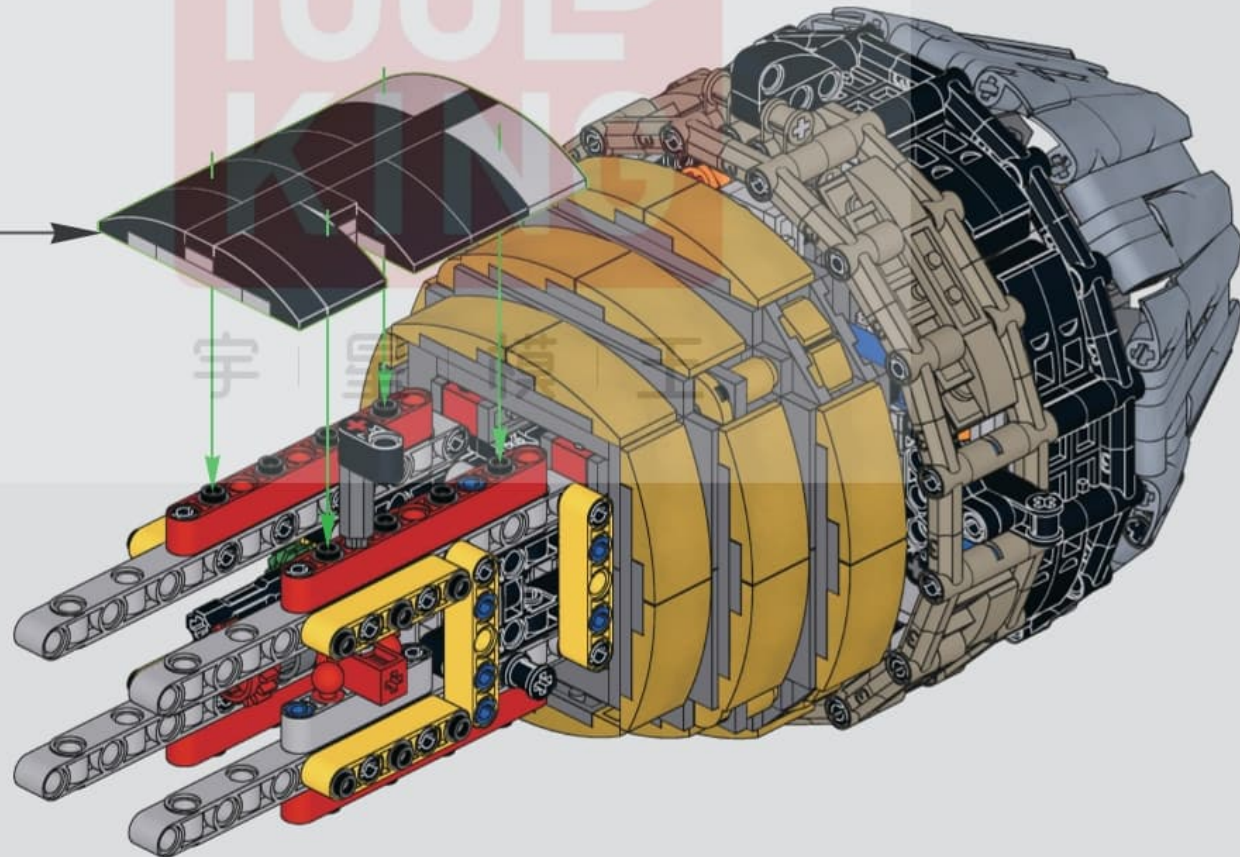
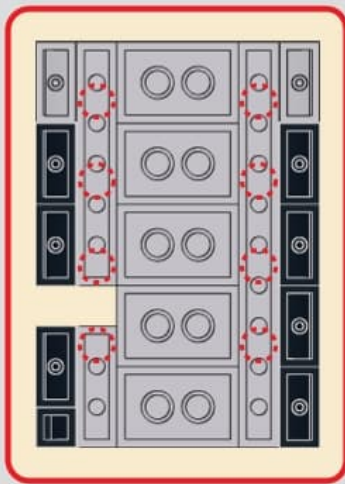



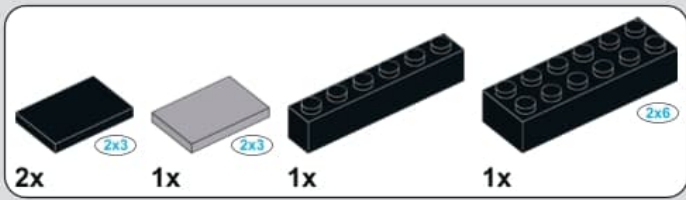

142

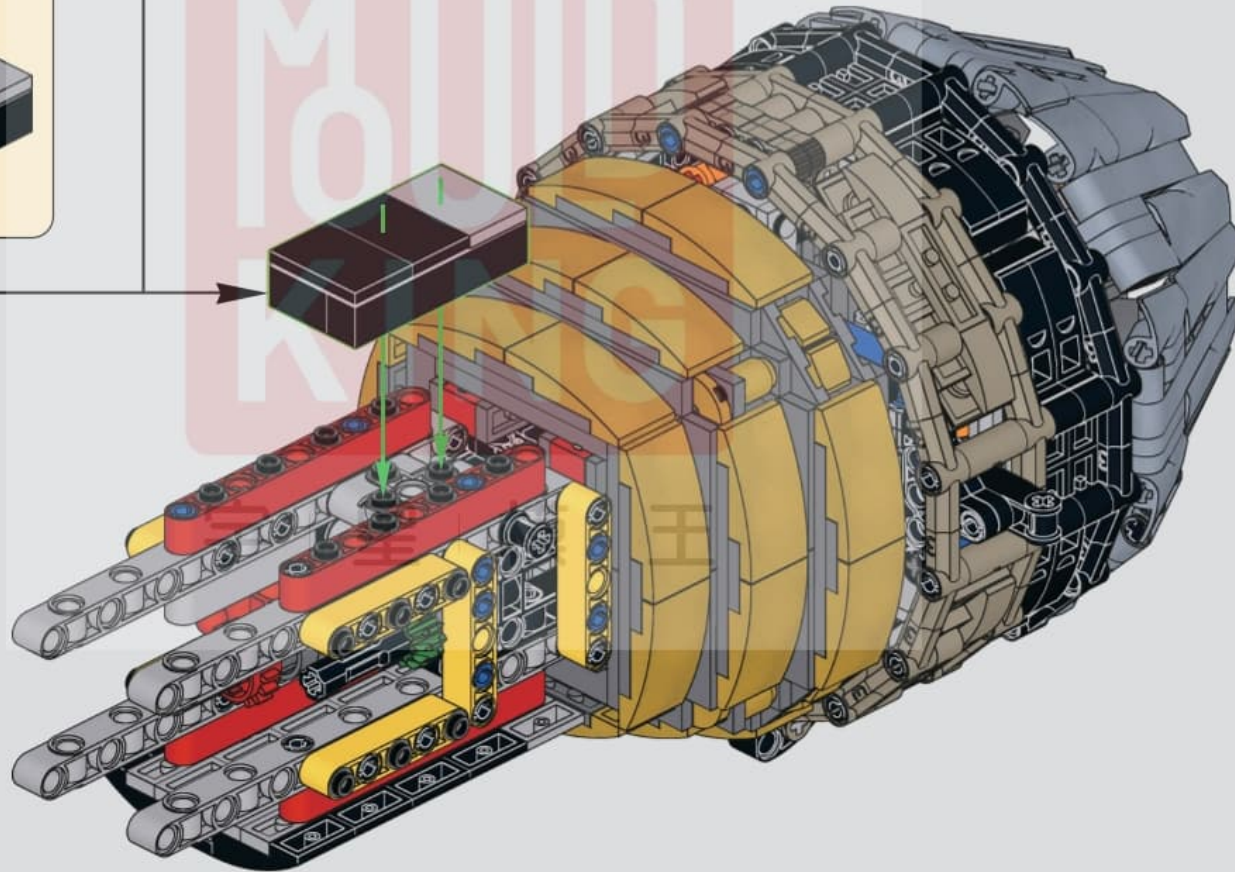
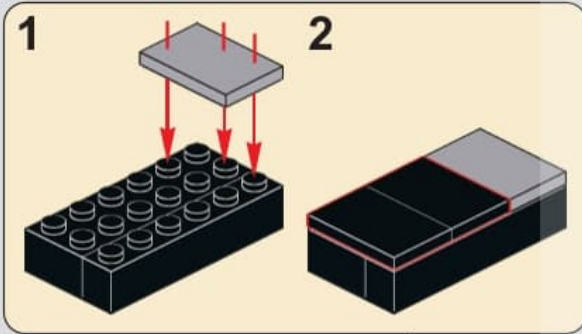
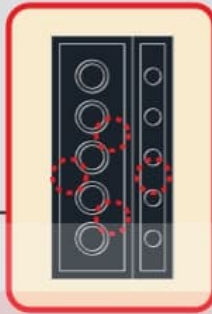

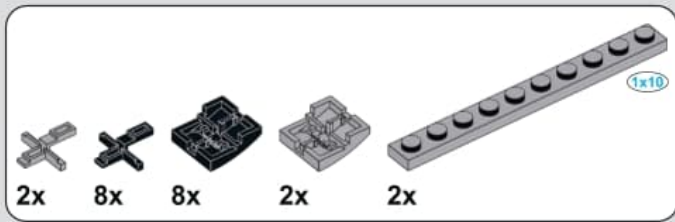

# 143

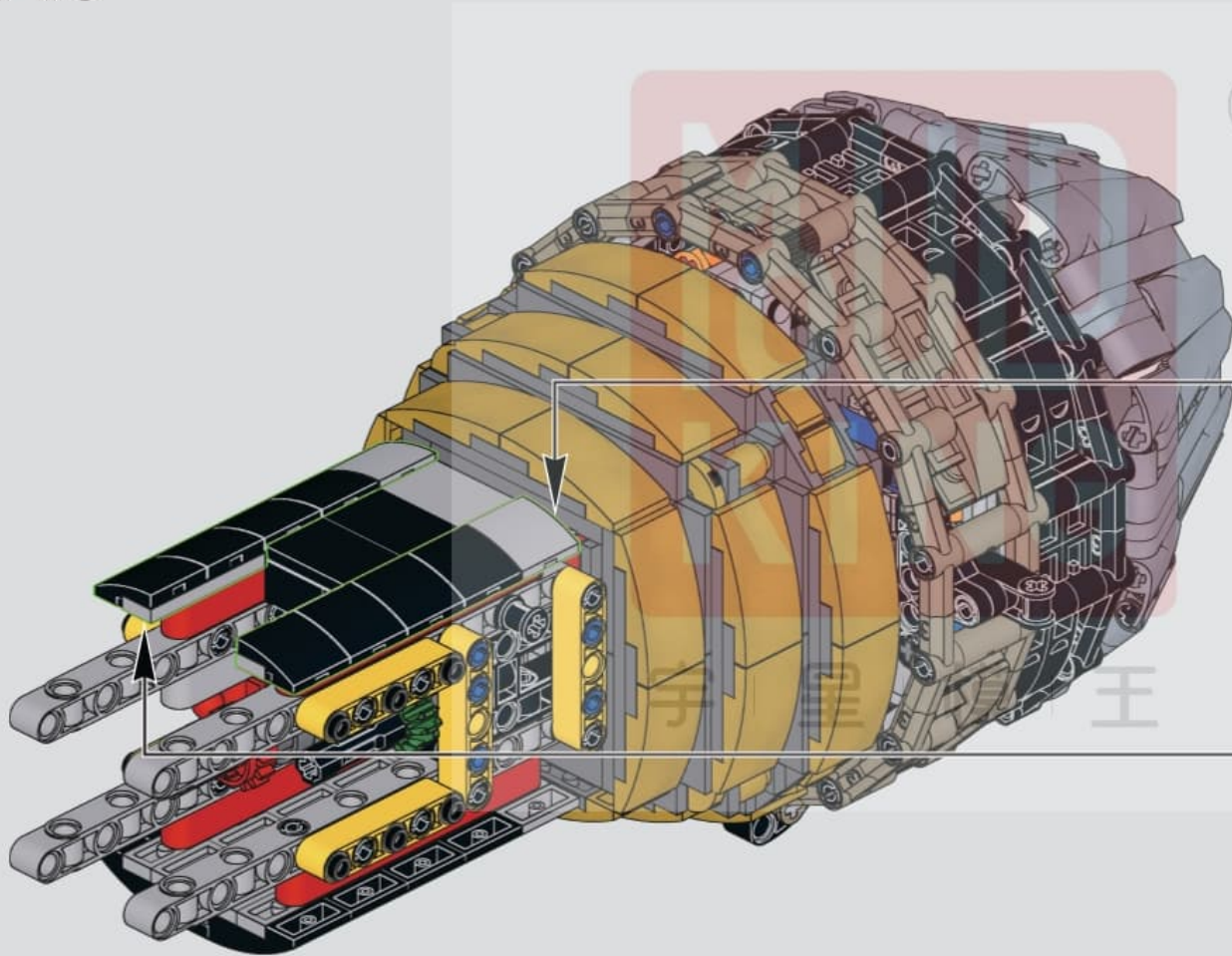

(R)

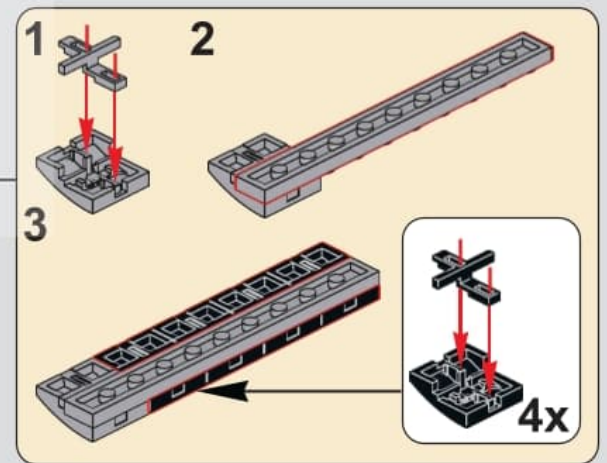
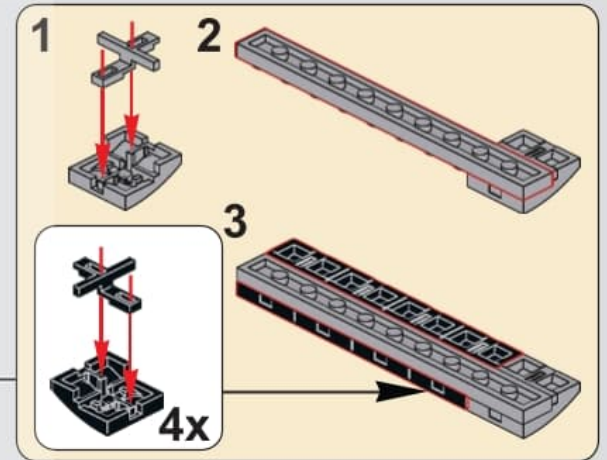



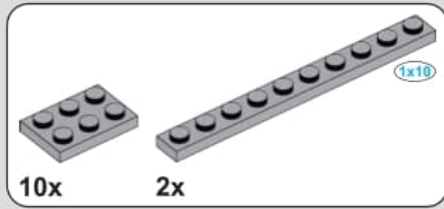
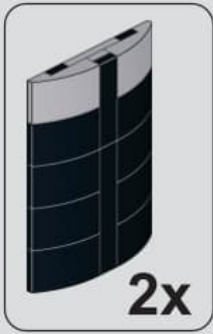

144

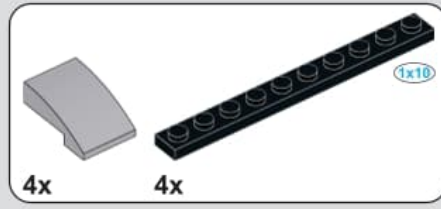
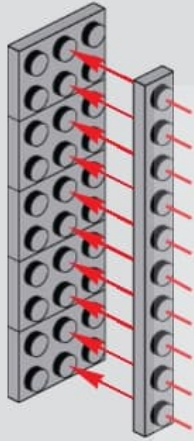

145

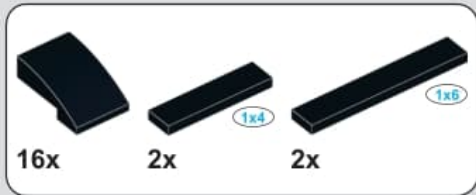
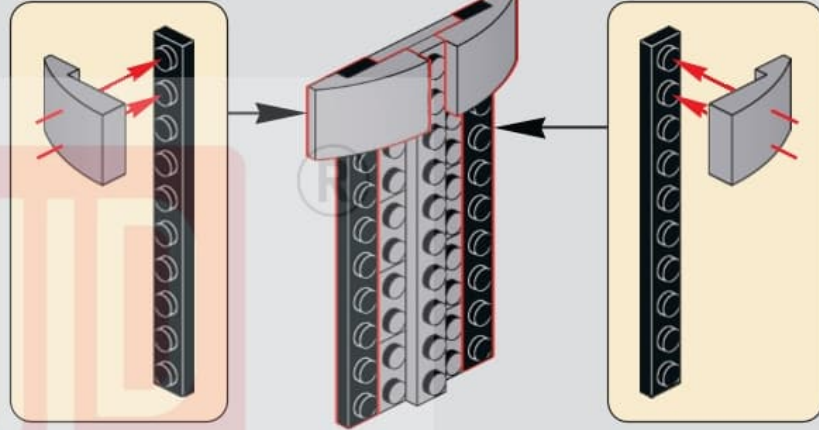

146

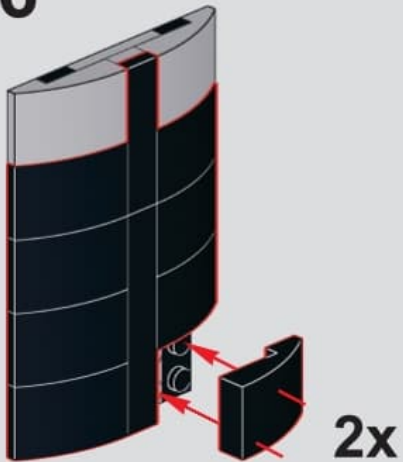

147

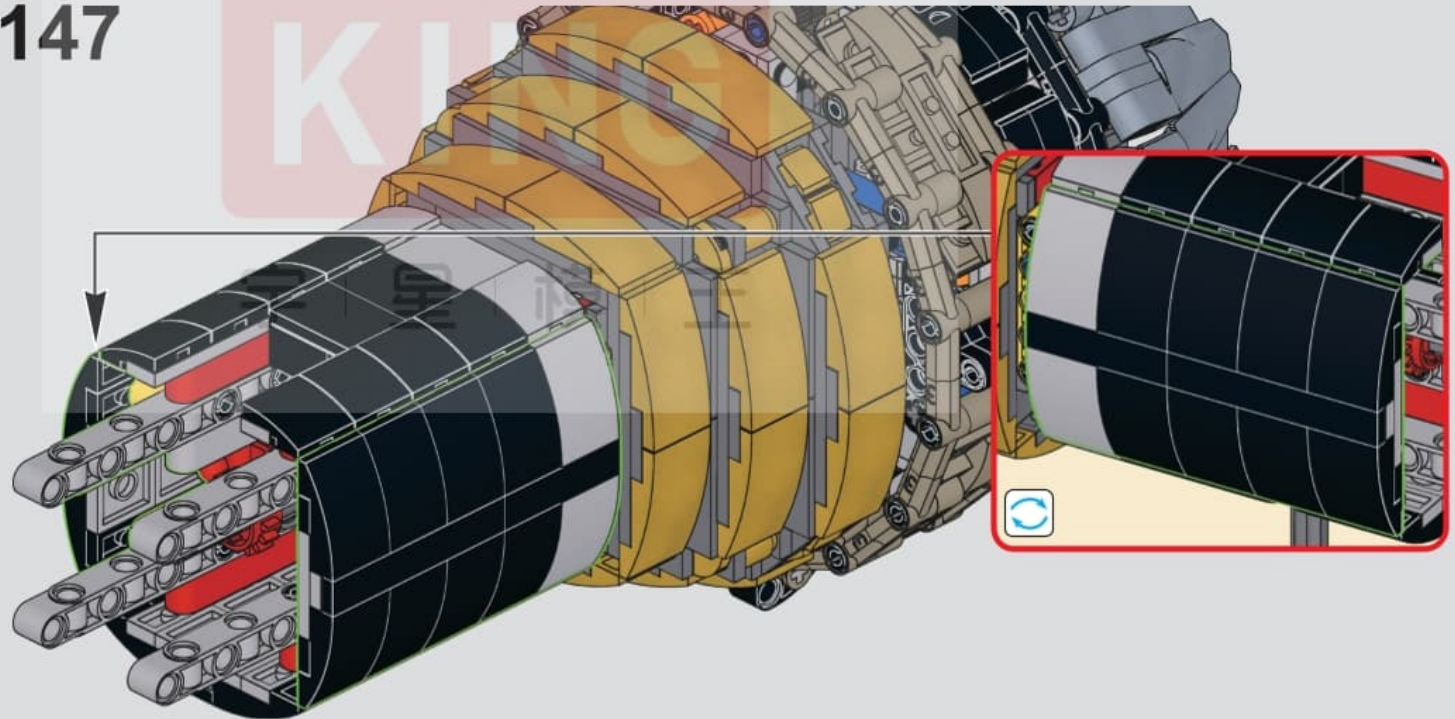



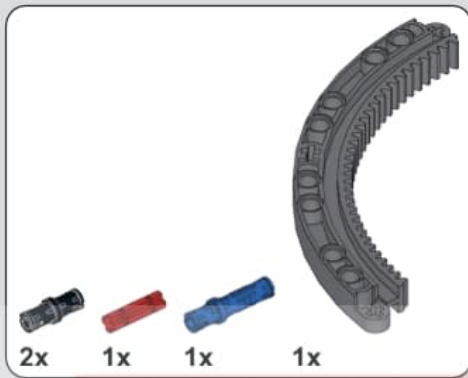
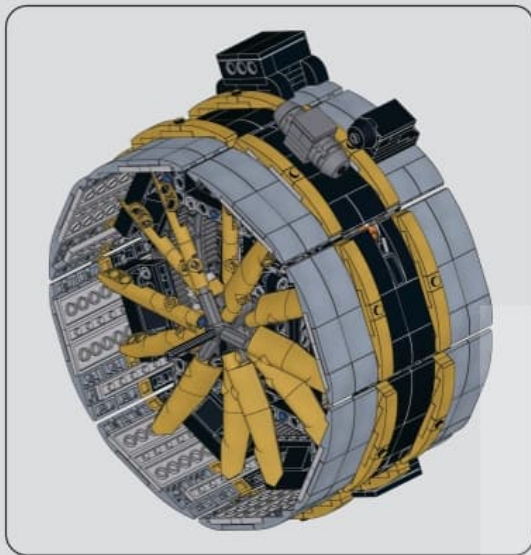

148

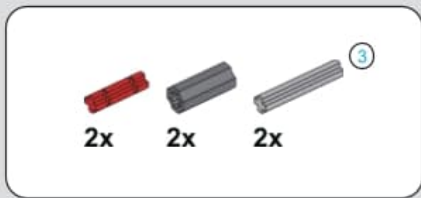
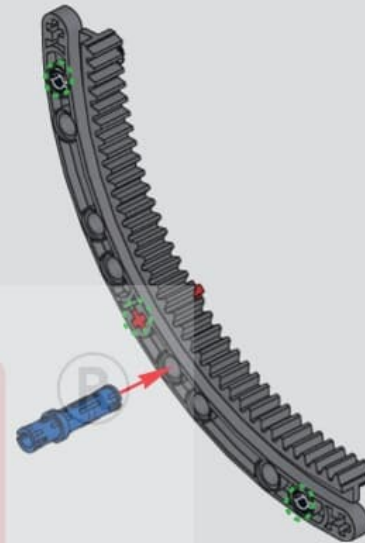

149

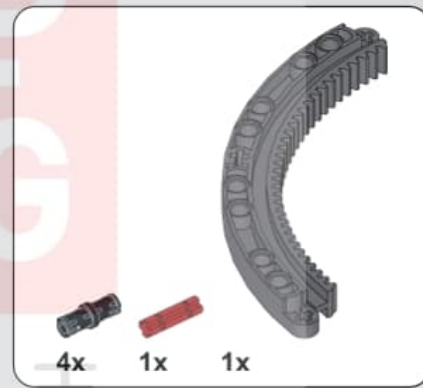
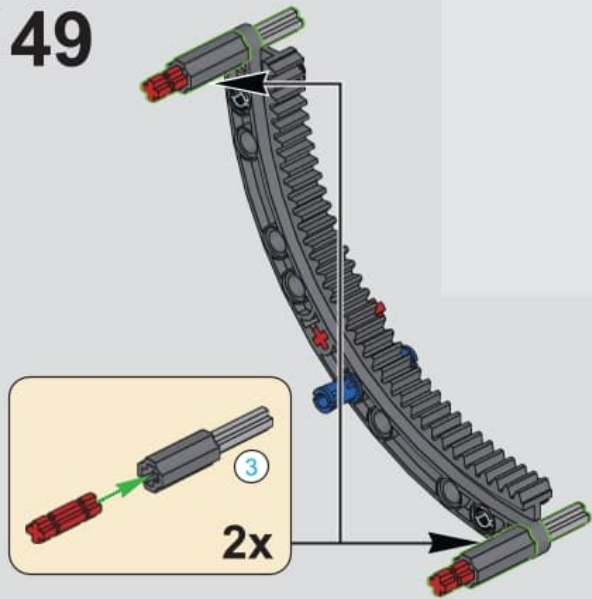

150

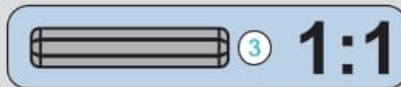
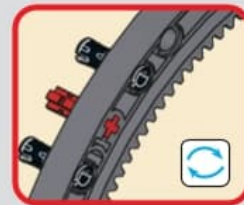
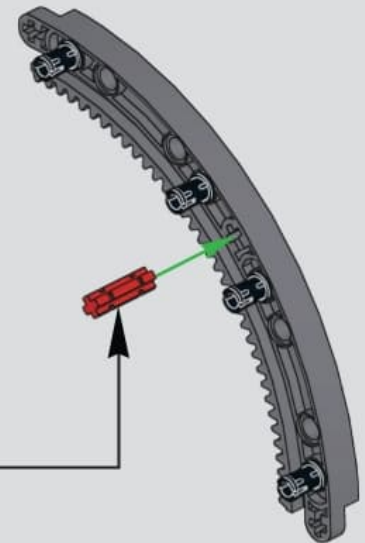

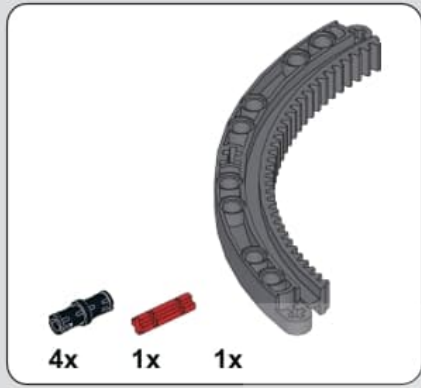
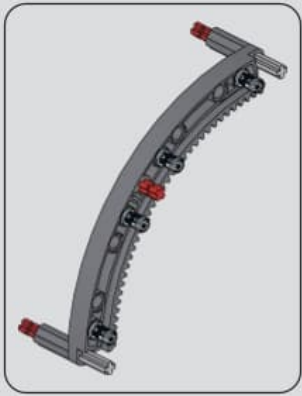

151

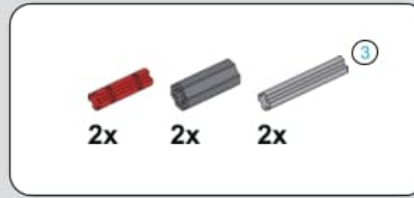
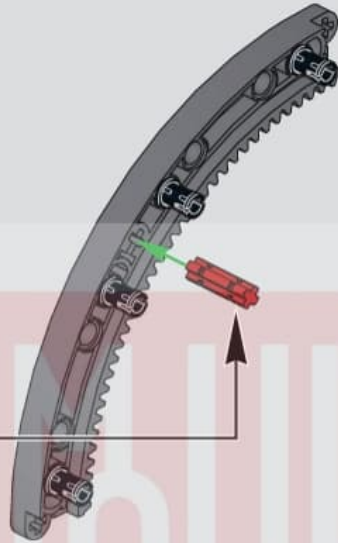
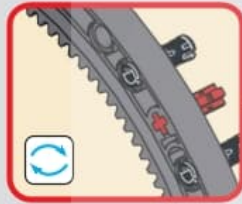

152

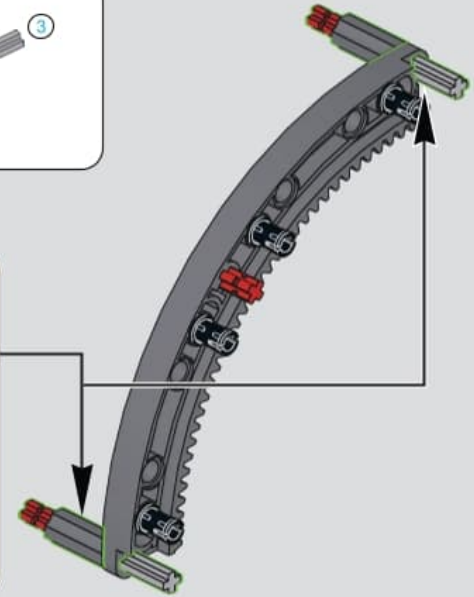
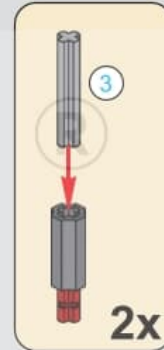

153

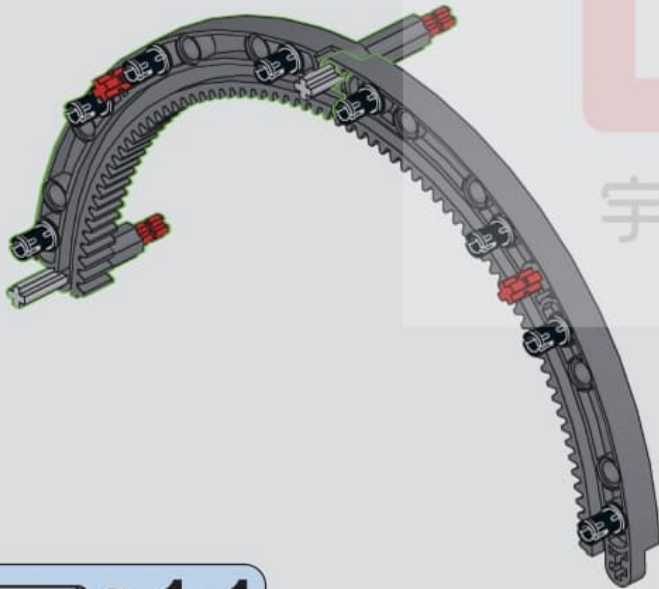

154

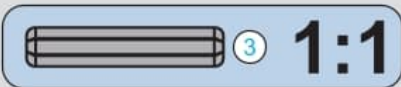
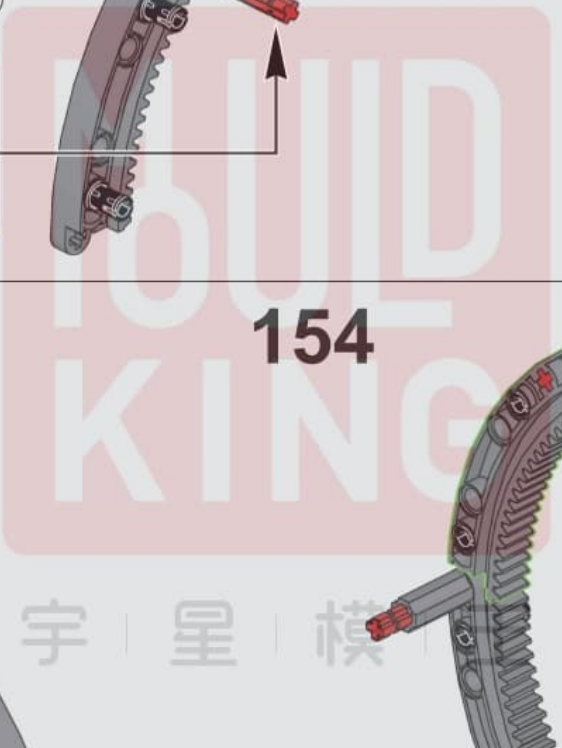
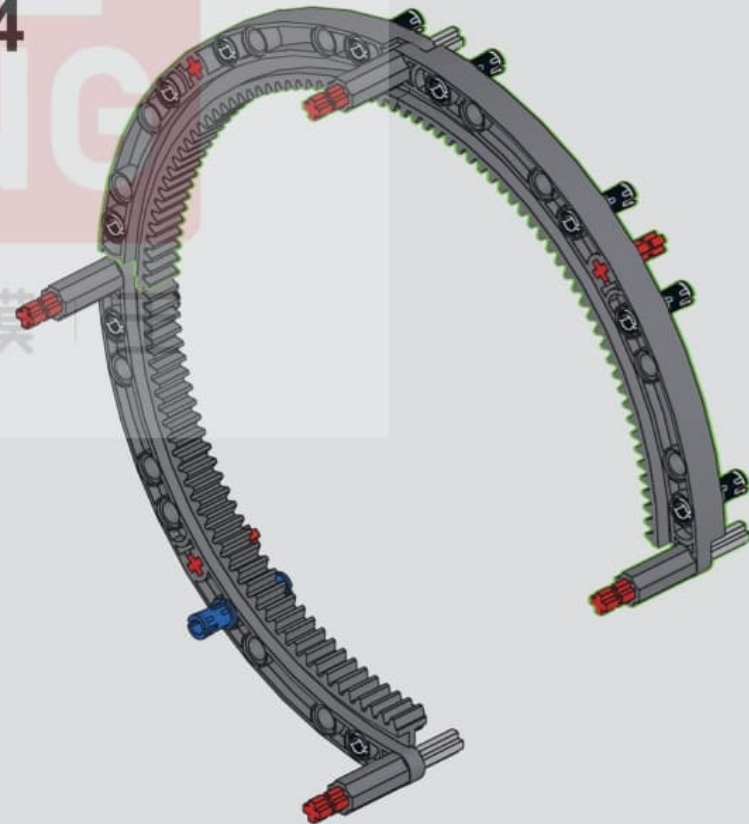



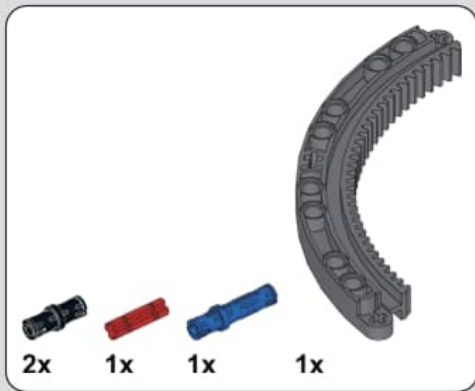

155

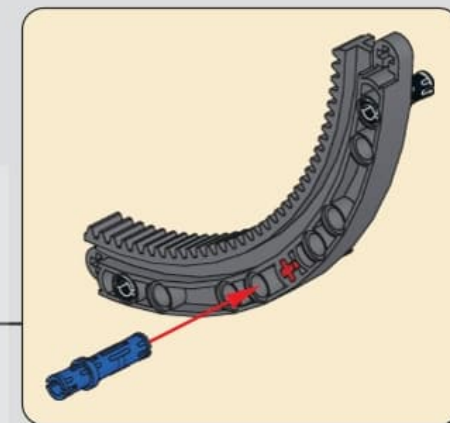
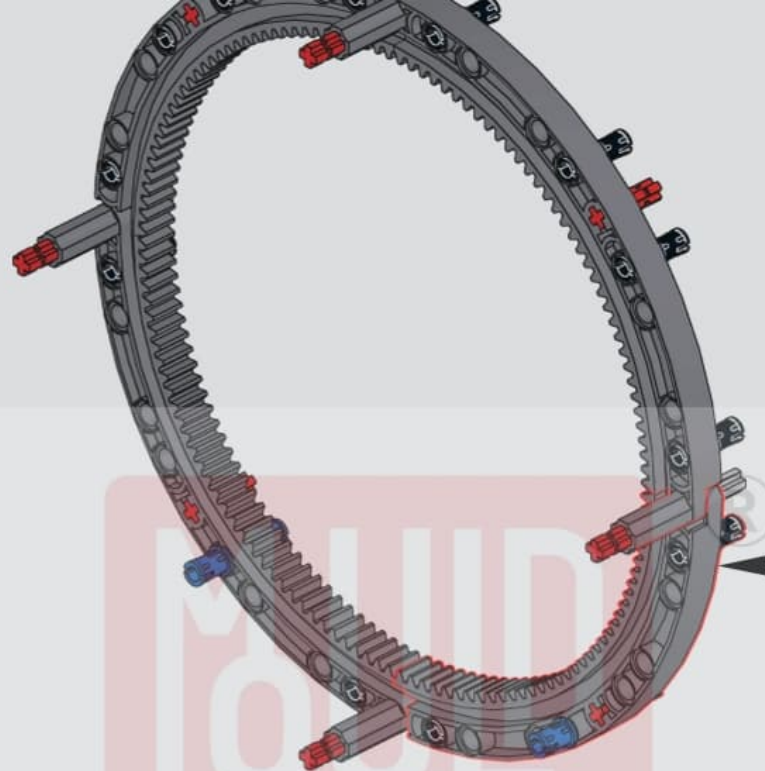

字 | 星 | 模

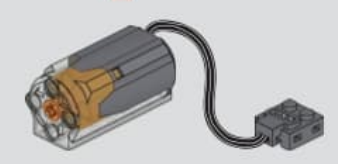



156

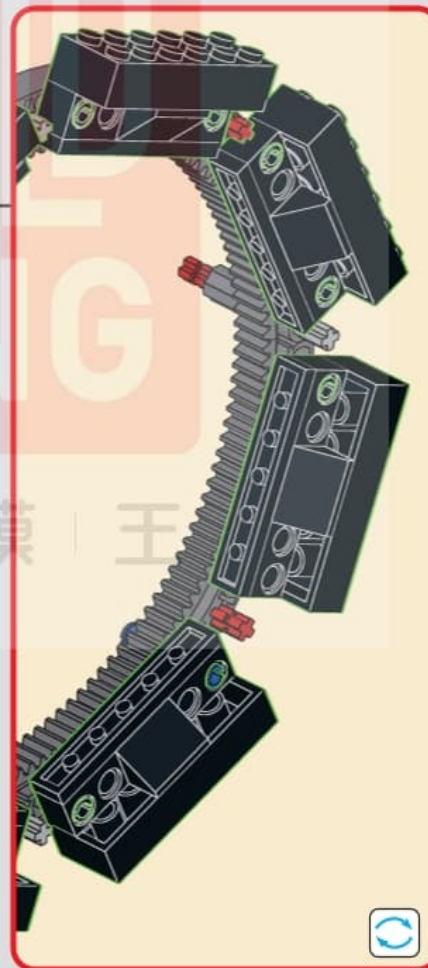
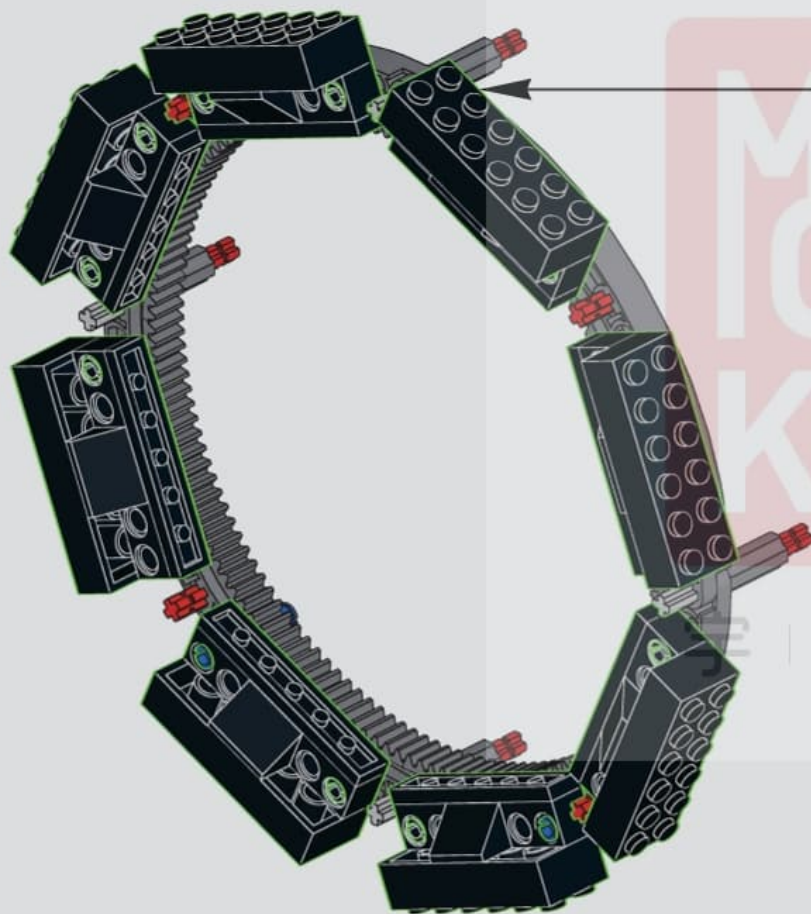
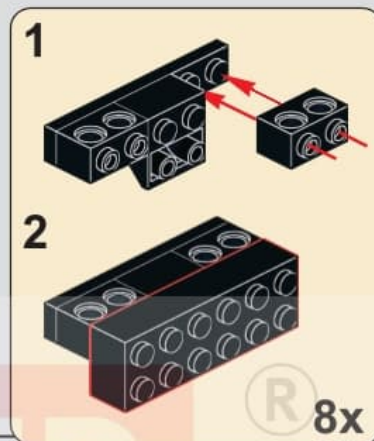



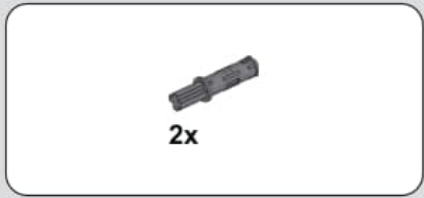

157

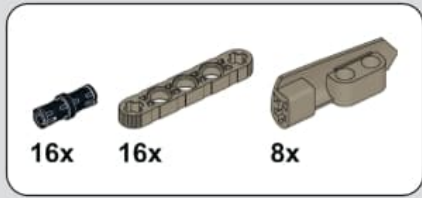
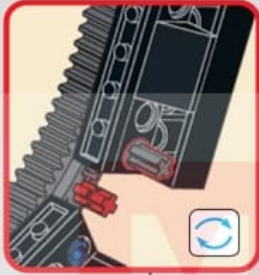

158

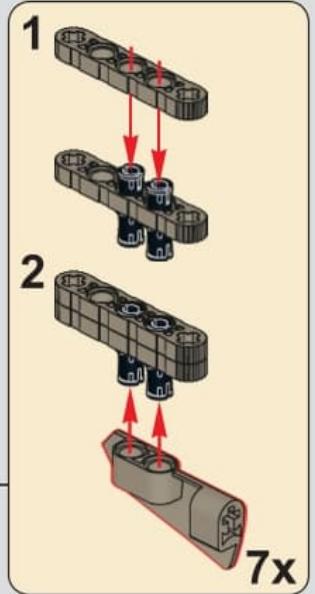
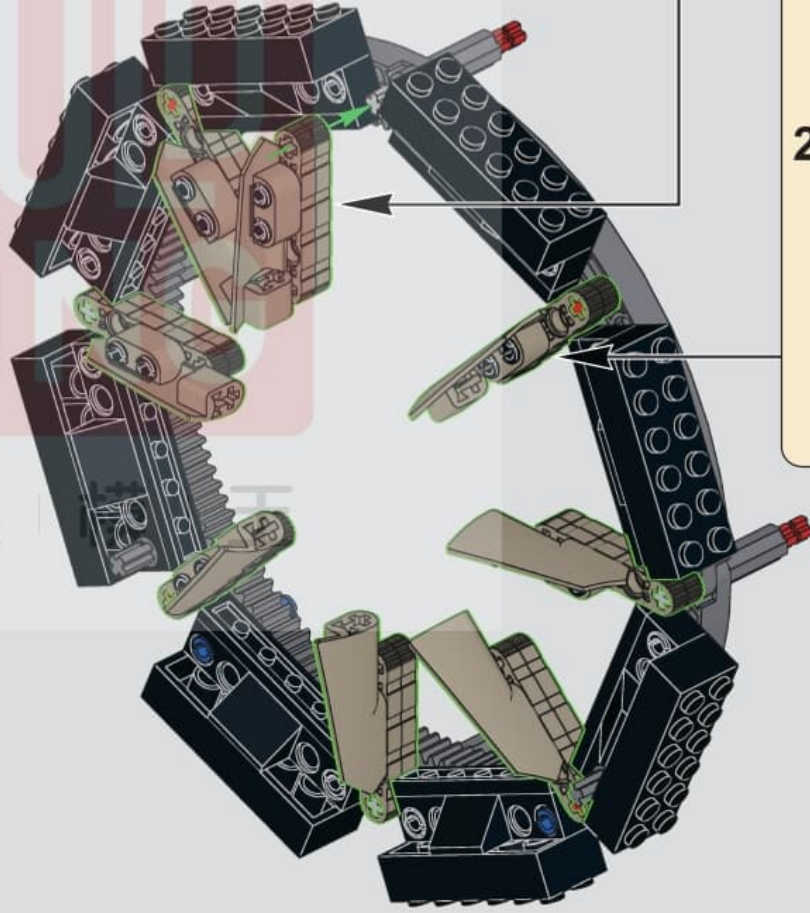
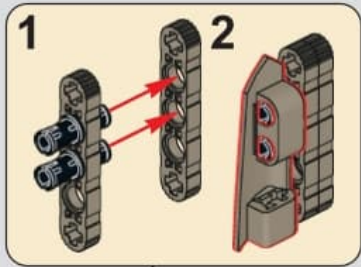

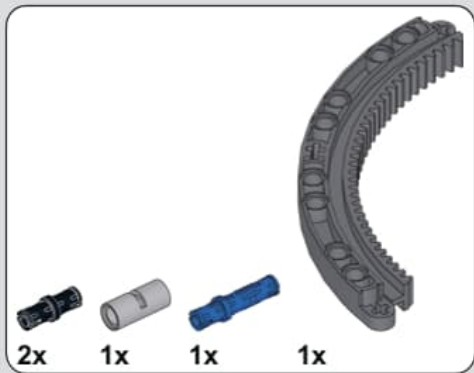

159

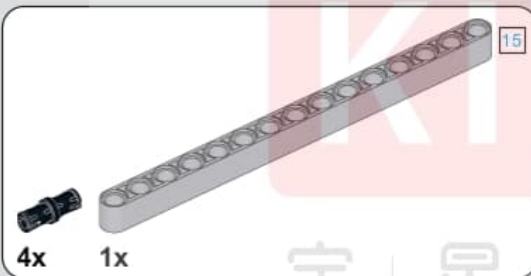
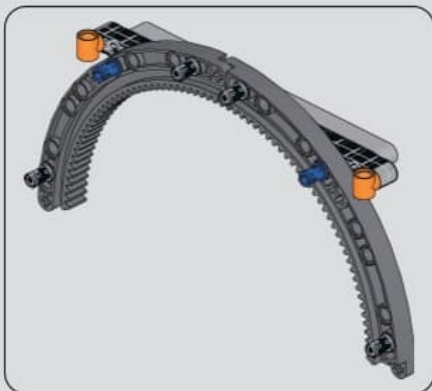
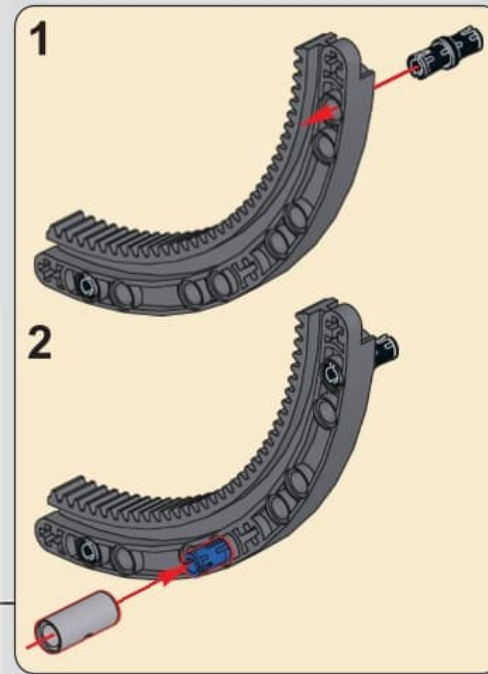
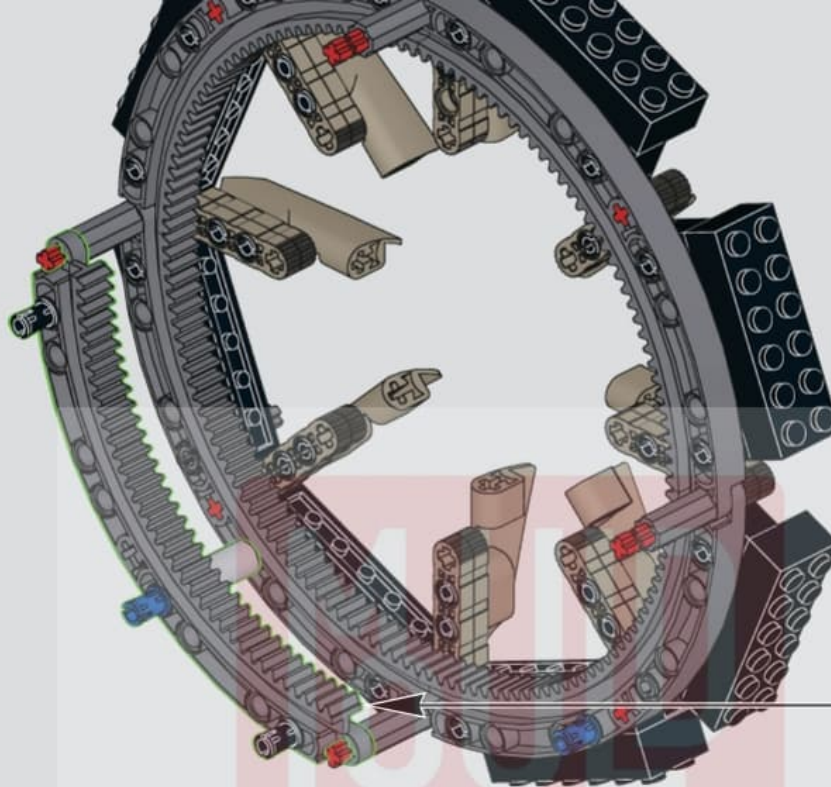

160

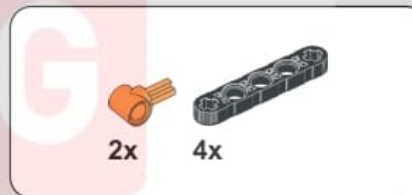
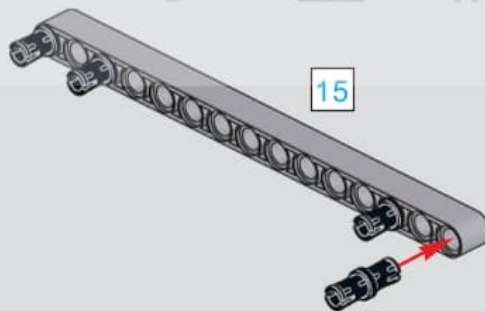

161

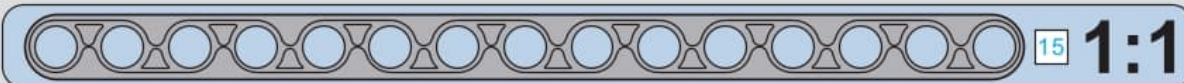
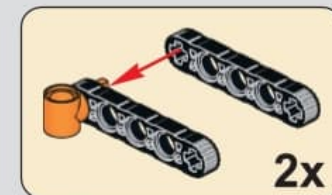
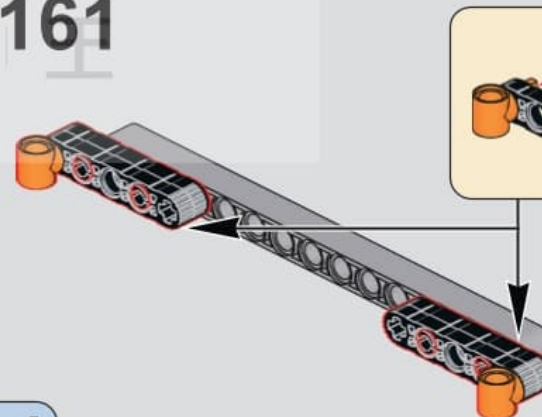



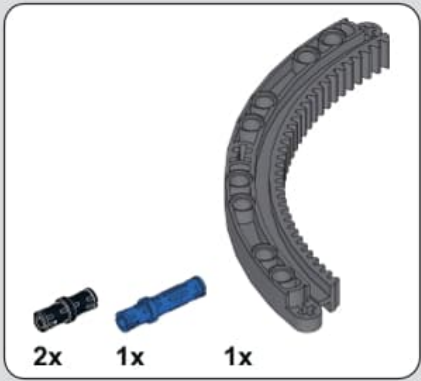

162

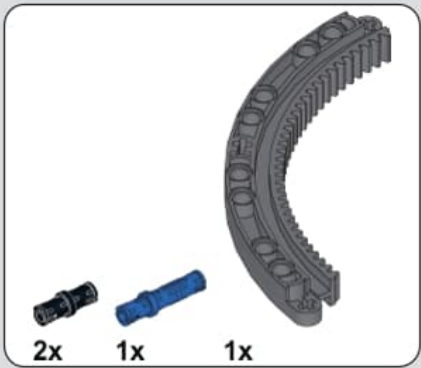
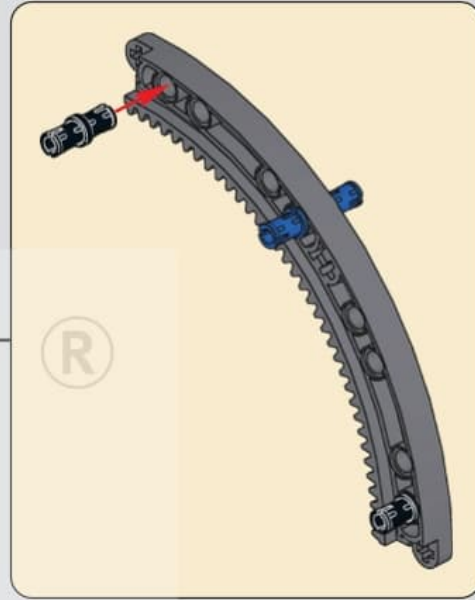
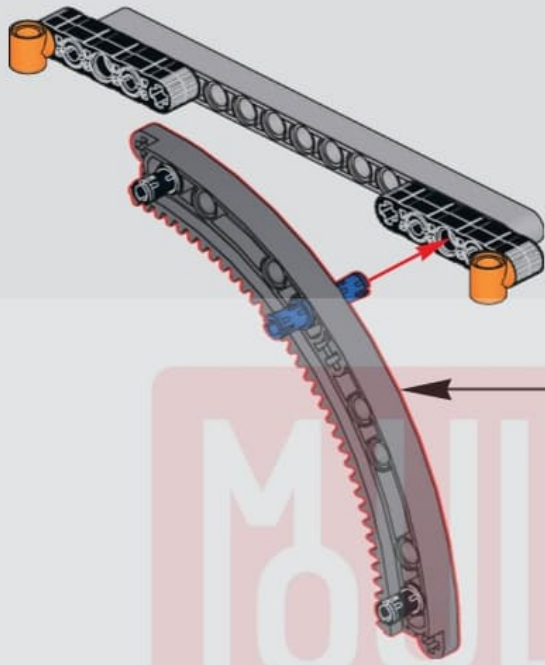

163

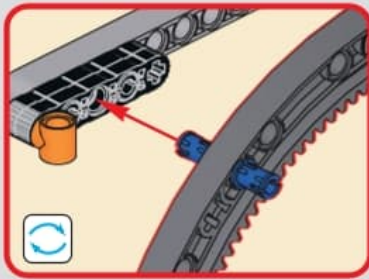
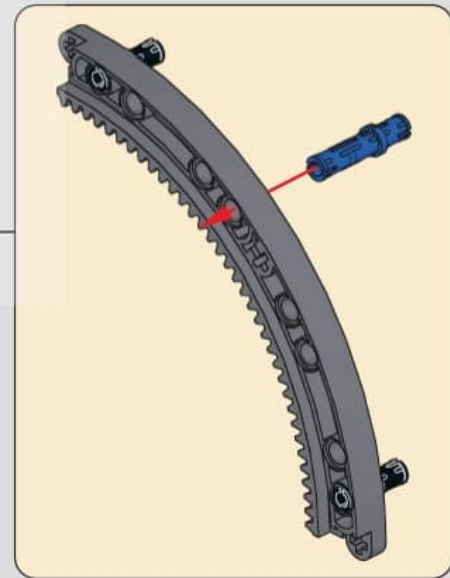
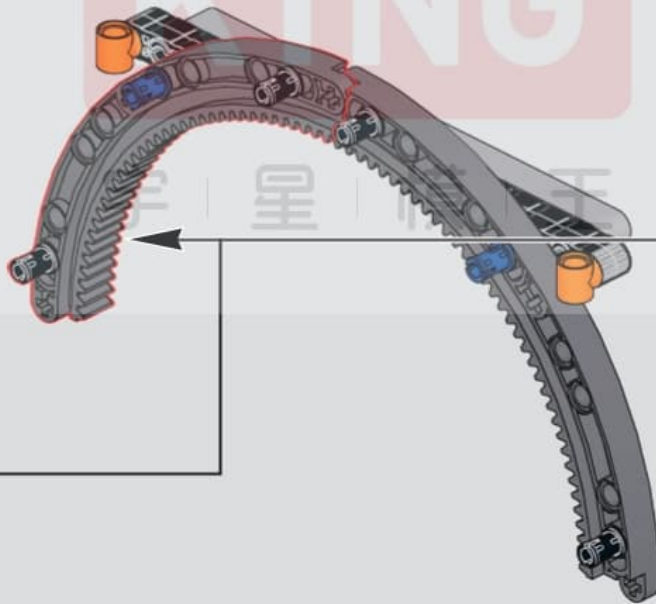

164

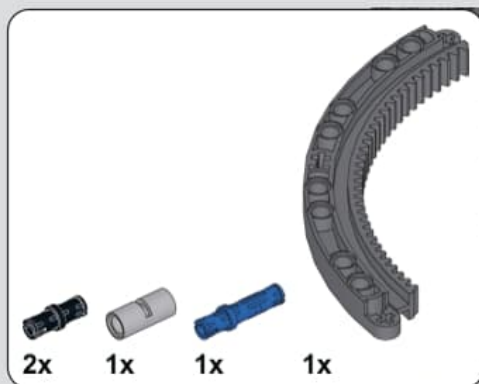
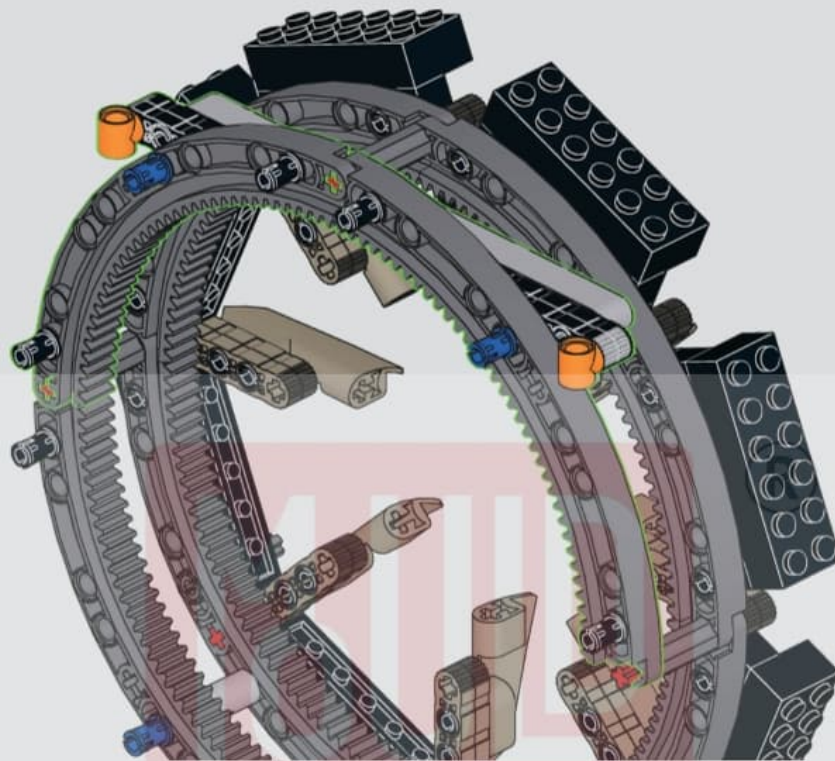

165

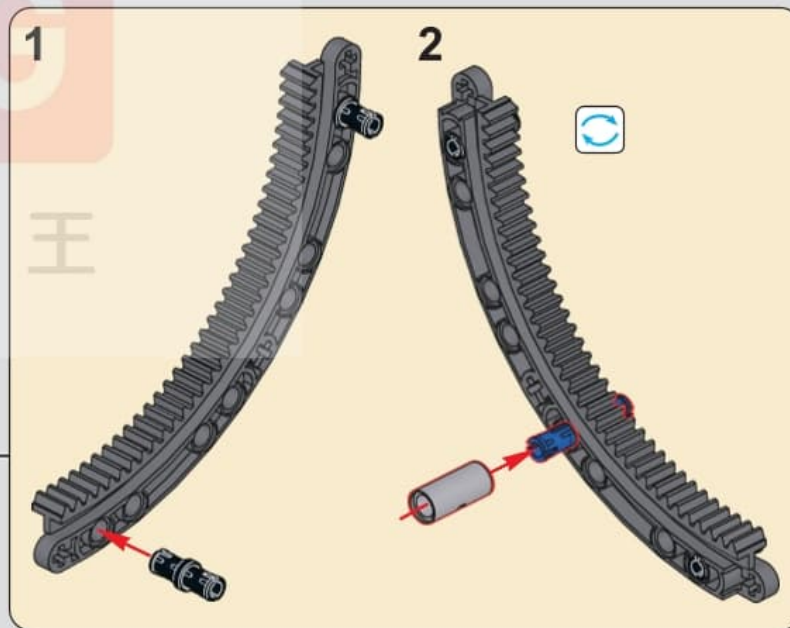
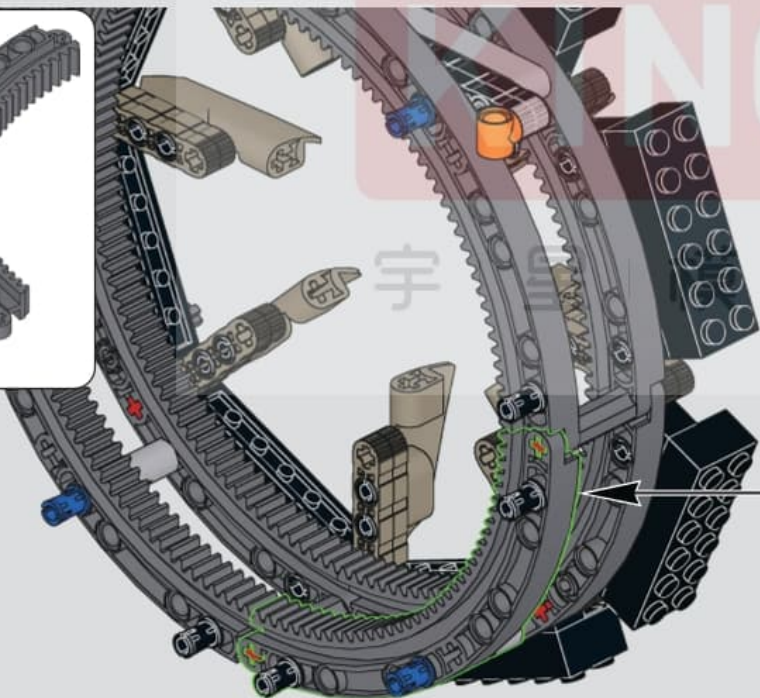



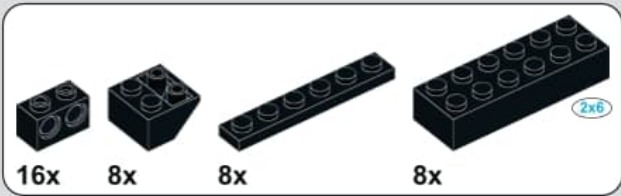

# 166

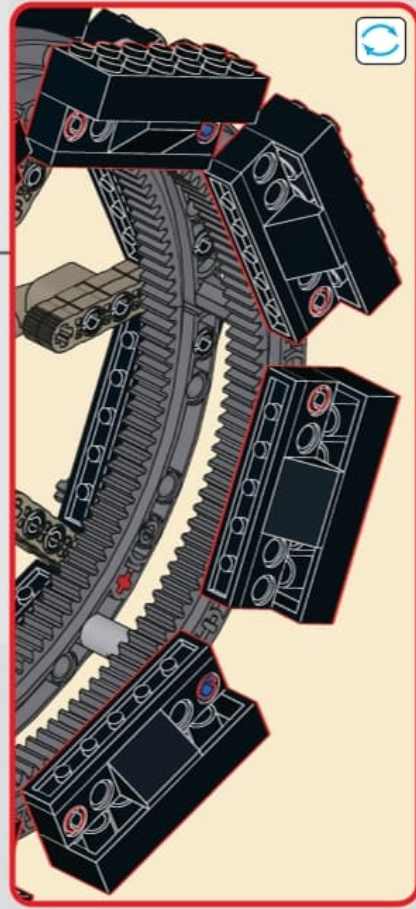
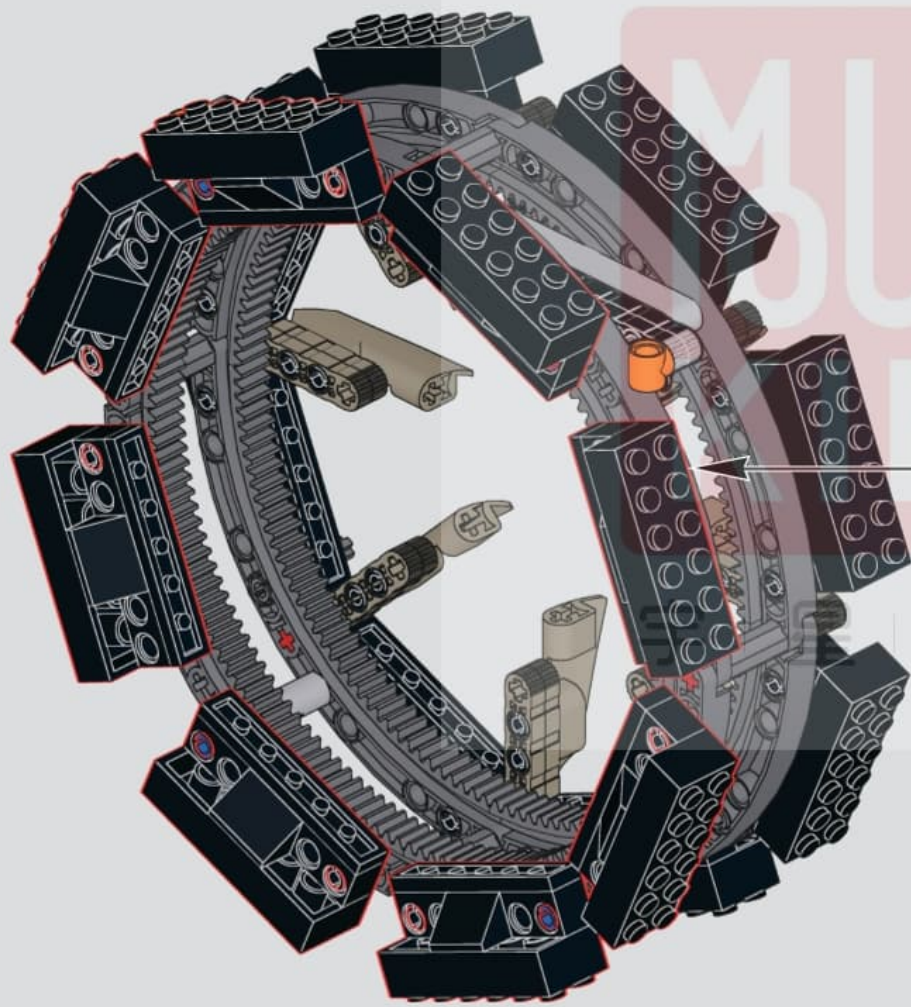
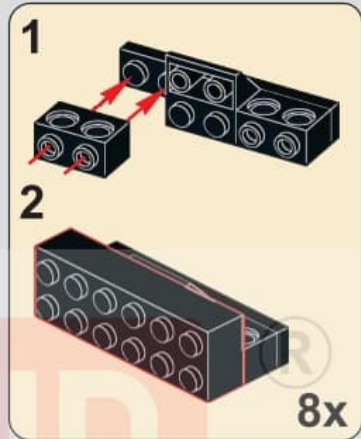



4x

167

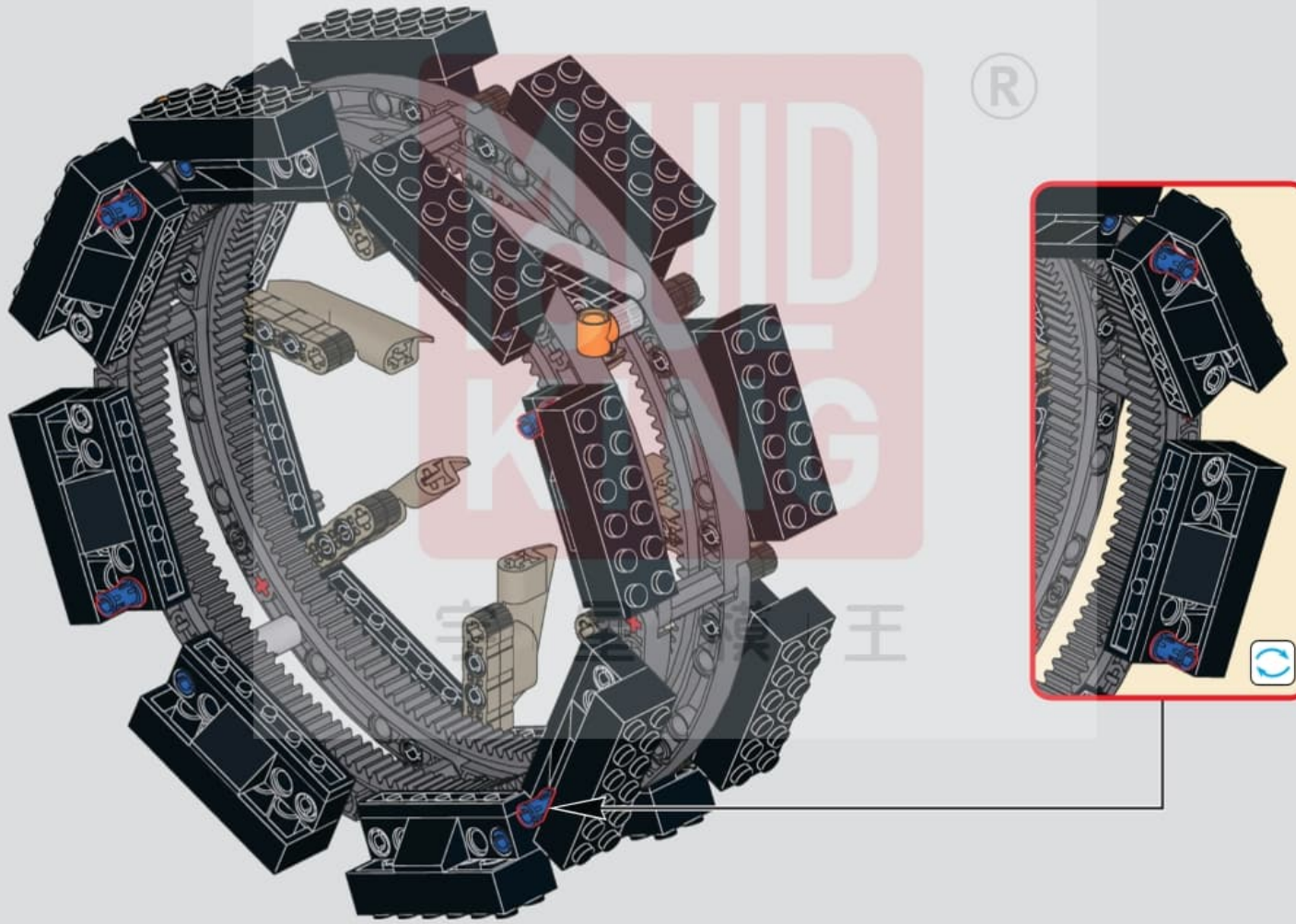



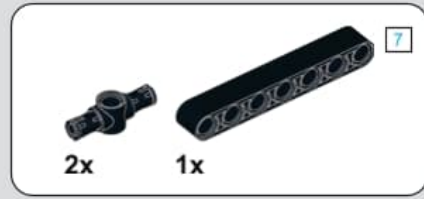
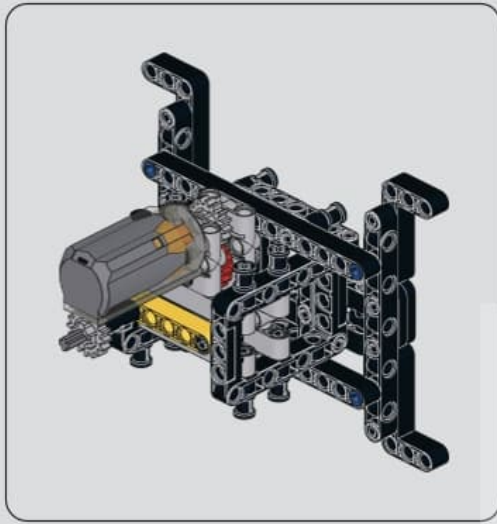

168

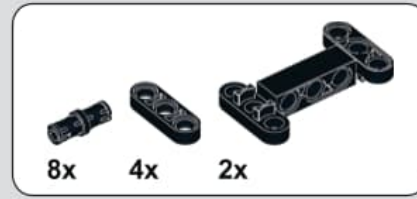

169

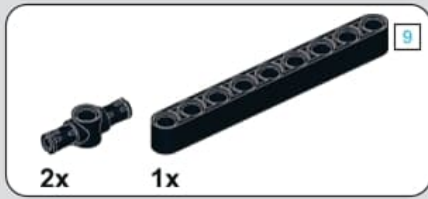
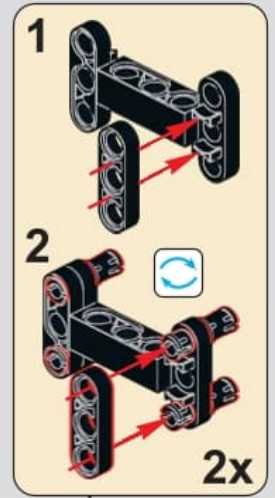
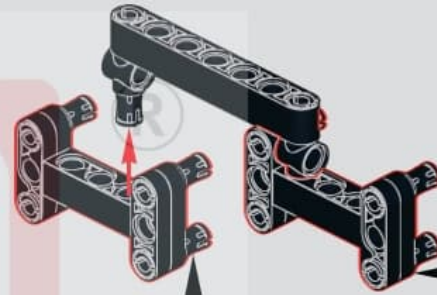

170

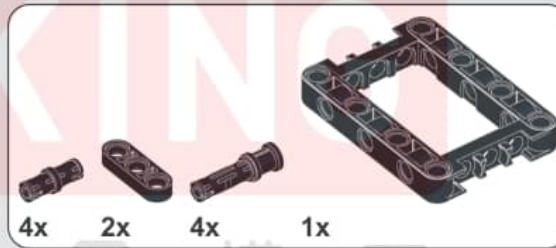
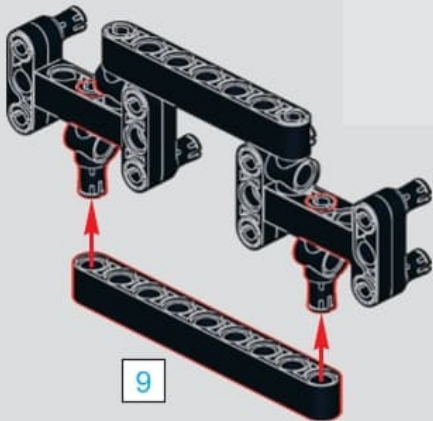

171

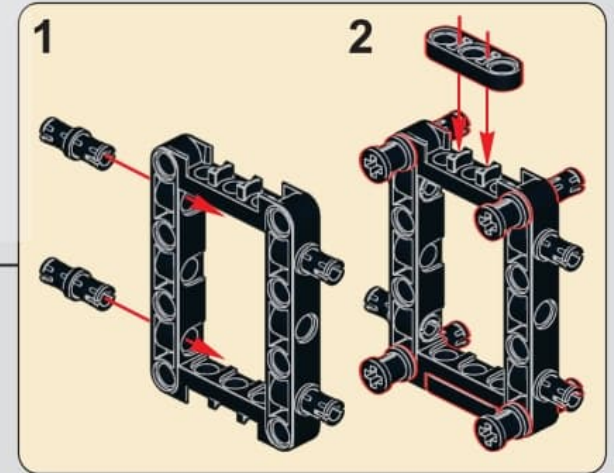
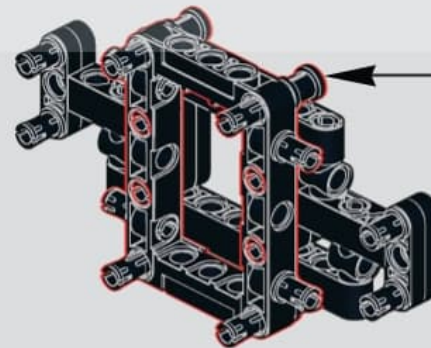

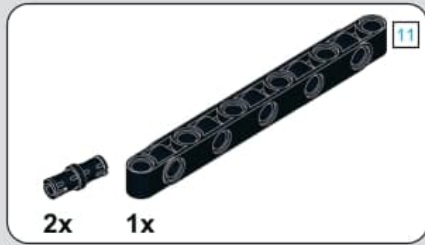
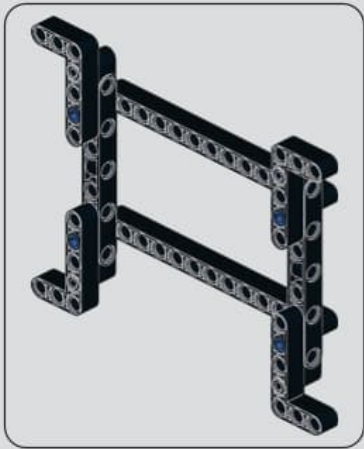

172



173

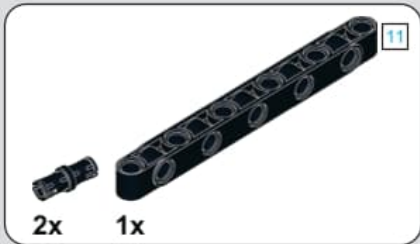
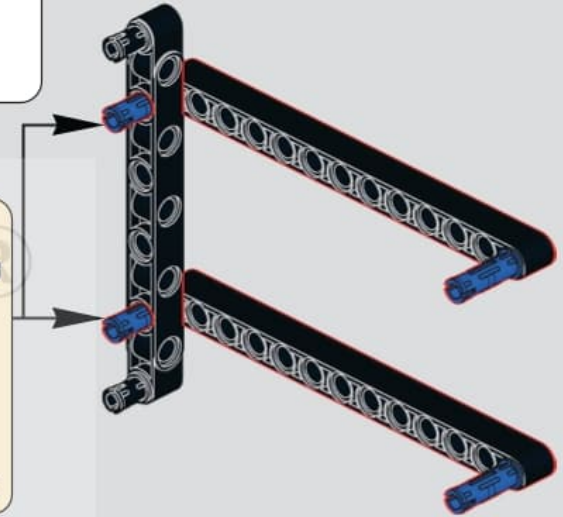
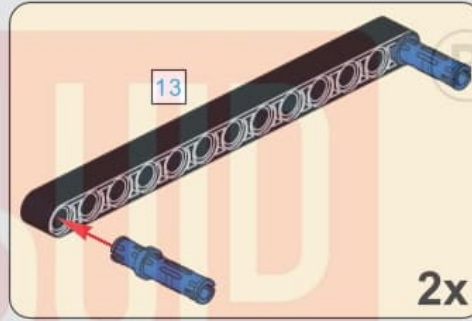

174

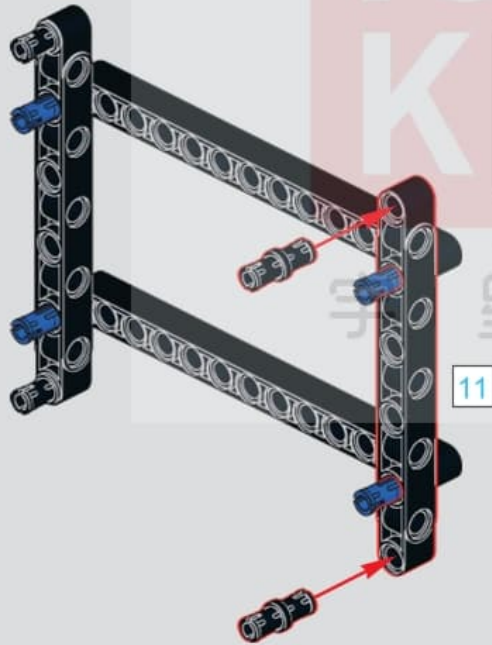

175

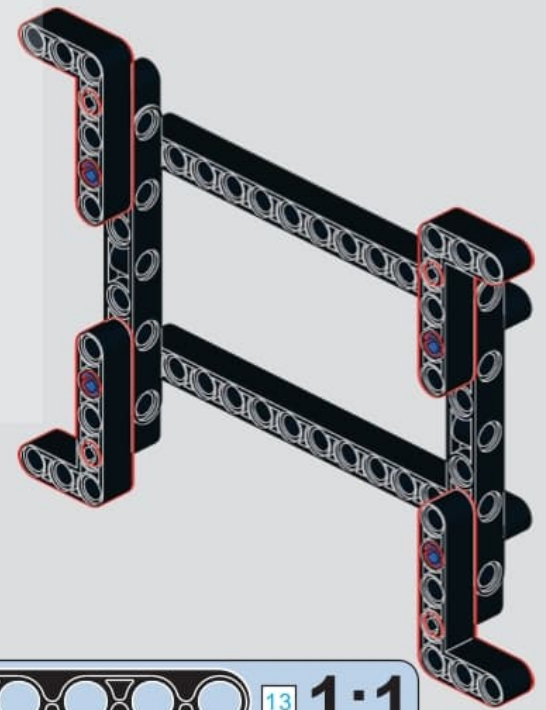



176

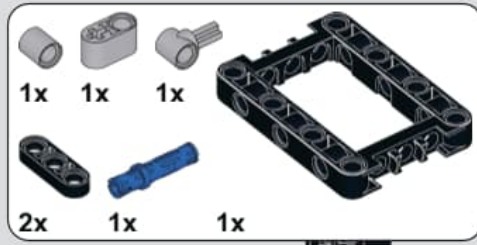
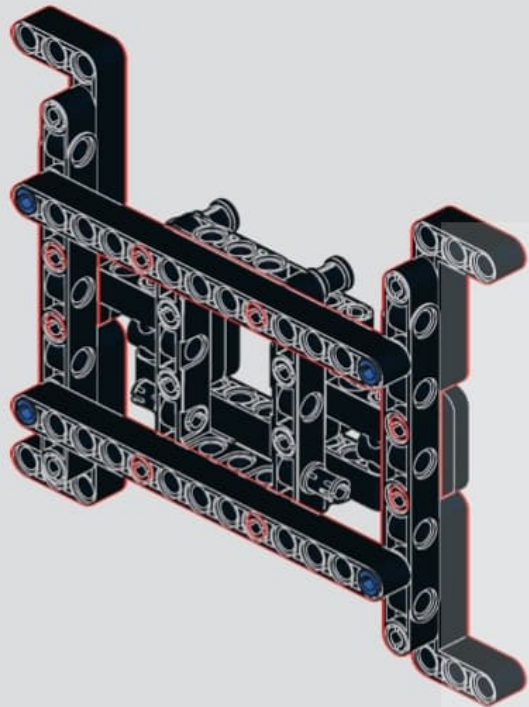

177

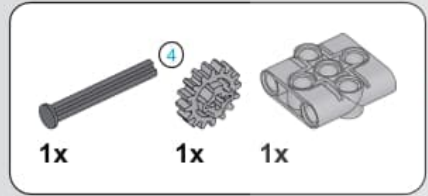
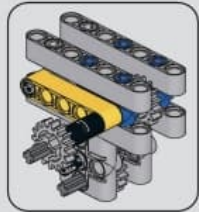
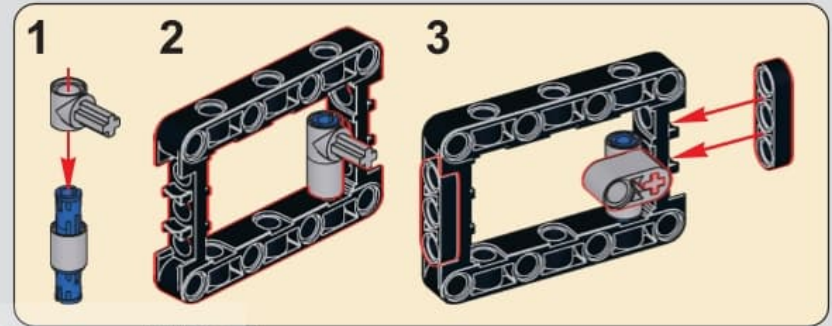
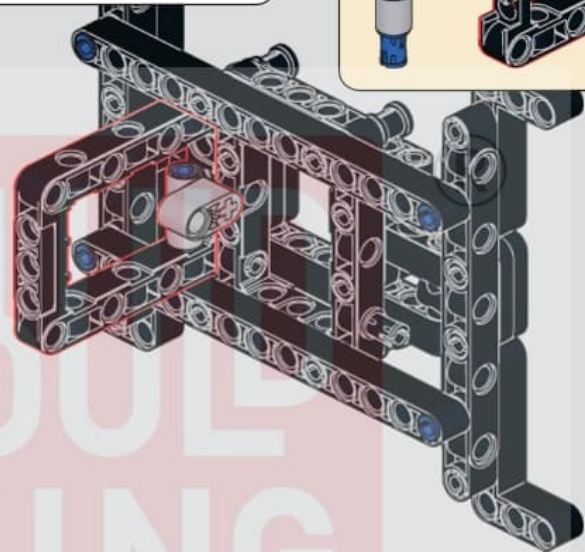

178



179



180

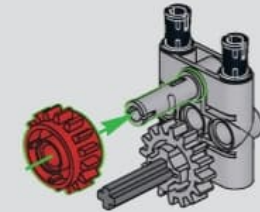
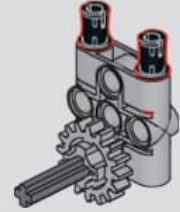
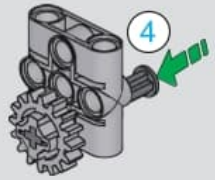

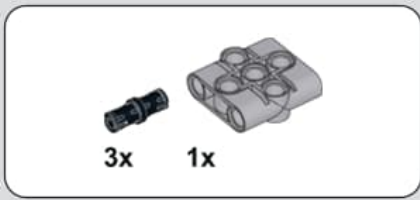

181

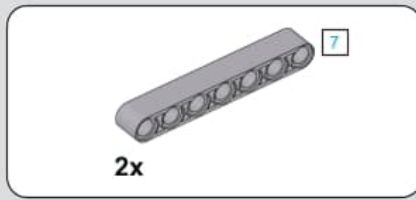
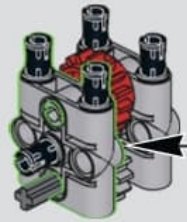
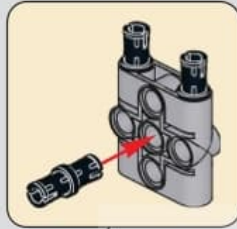

182

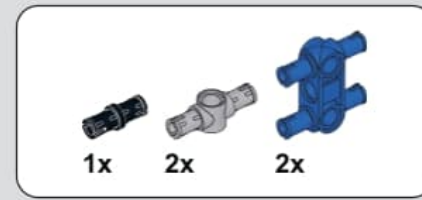
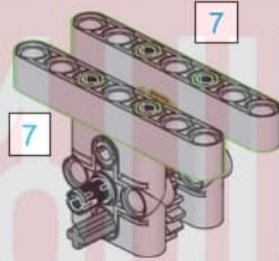

183

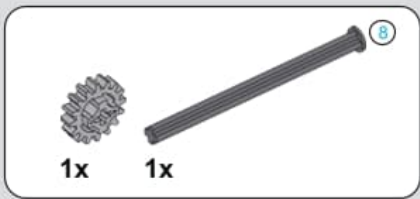
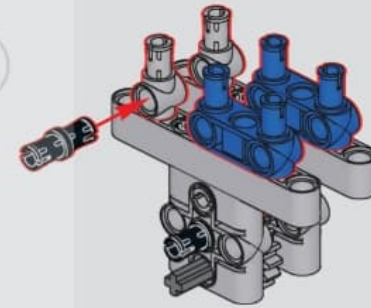

184

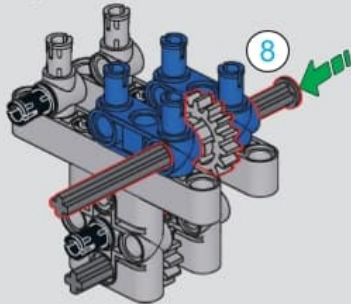

185

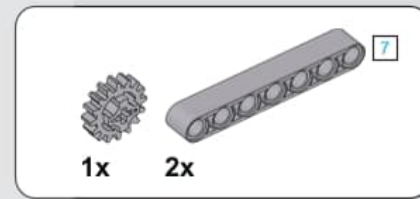
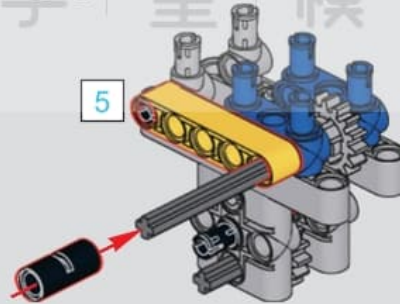

186

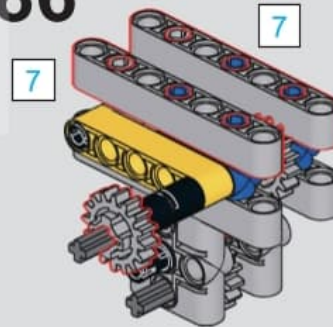





187

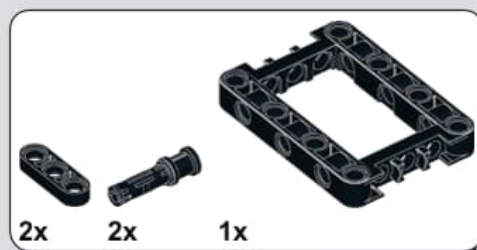
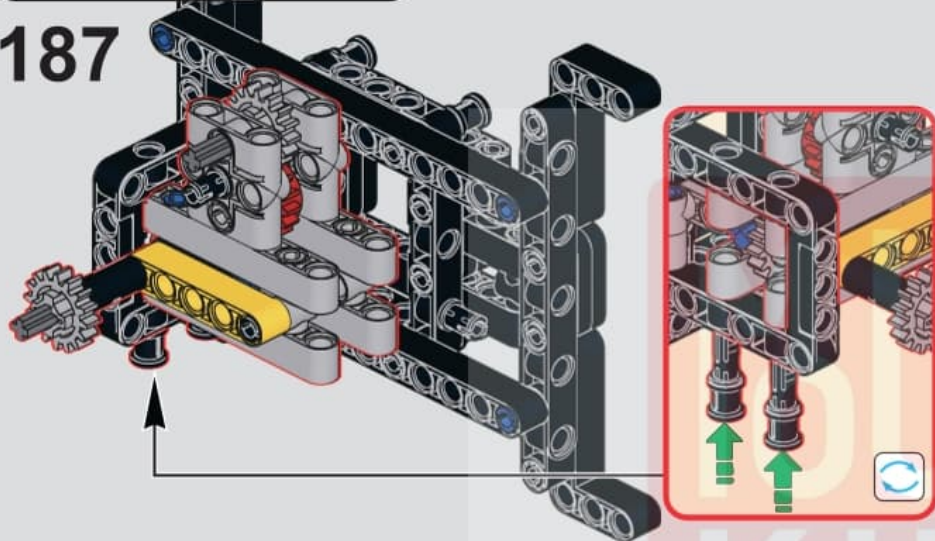

188

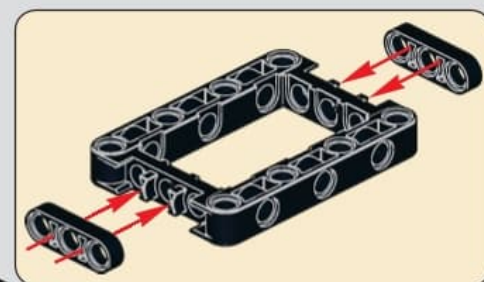
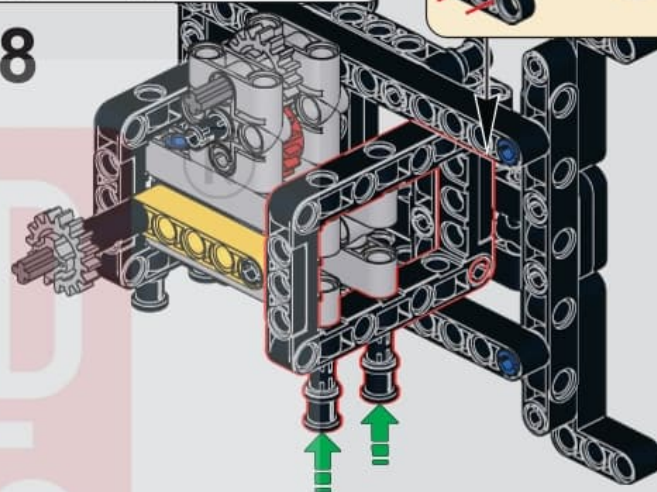

189

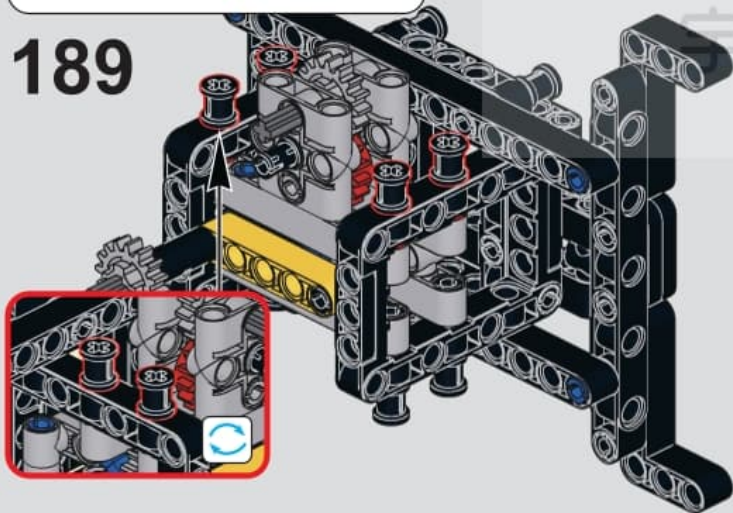

190

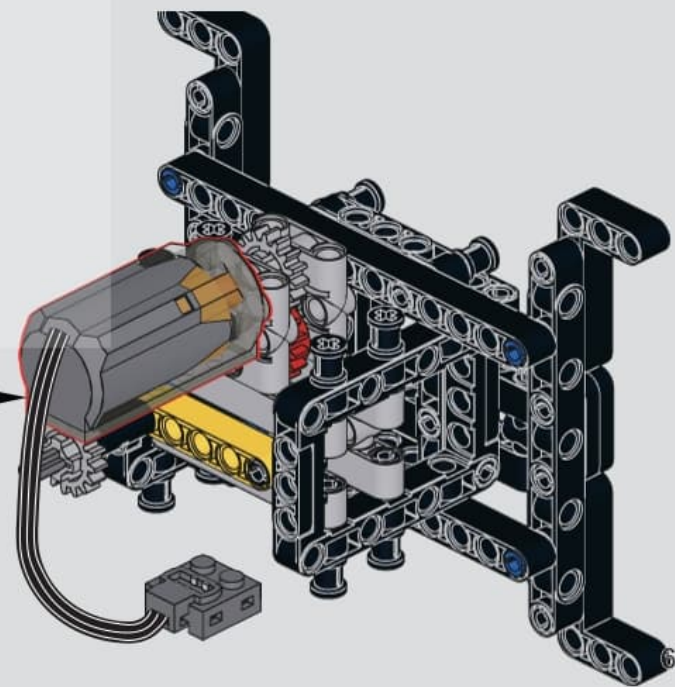
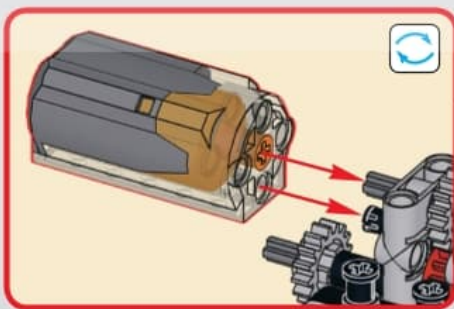

191

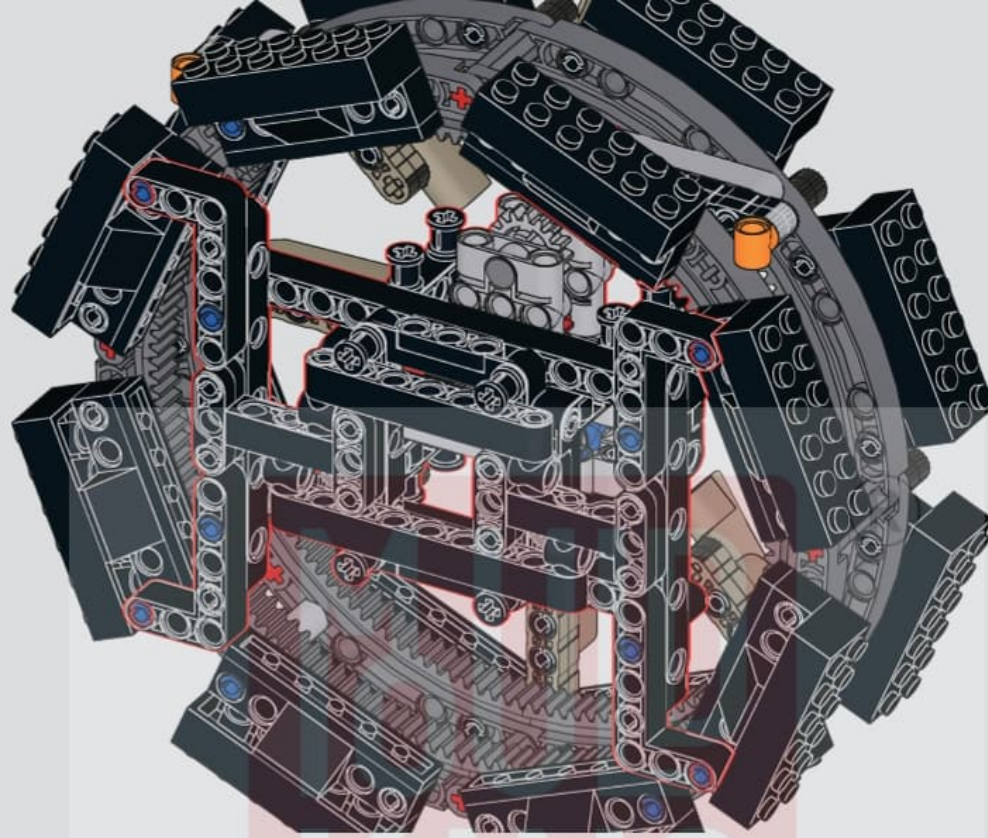

宇星

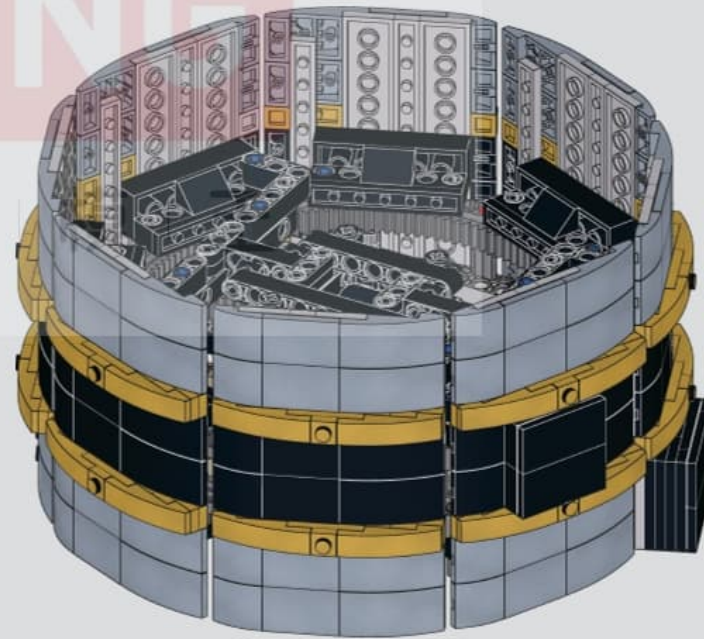



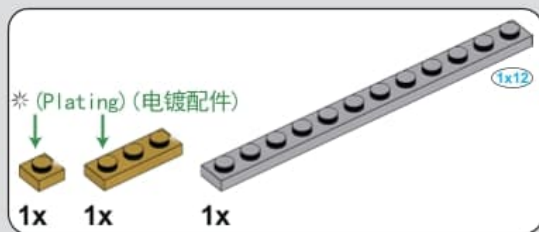
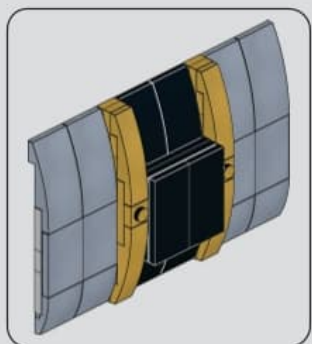

192



193

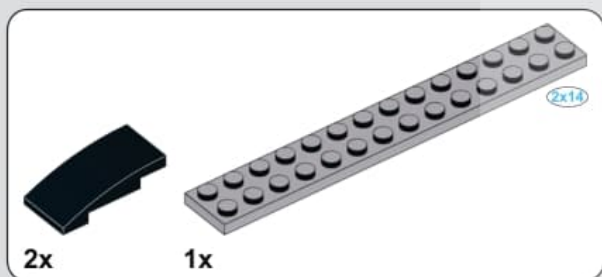
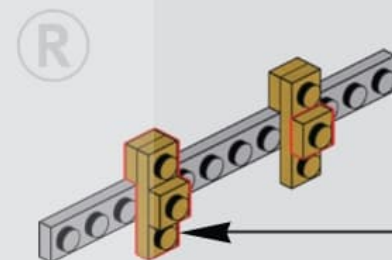
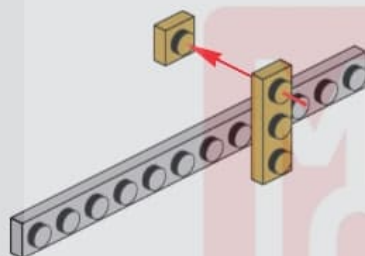
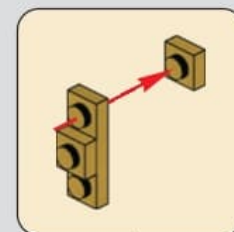

194

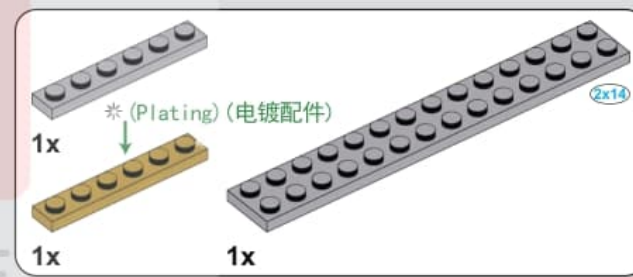
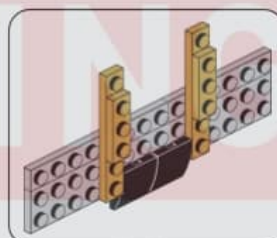

195

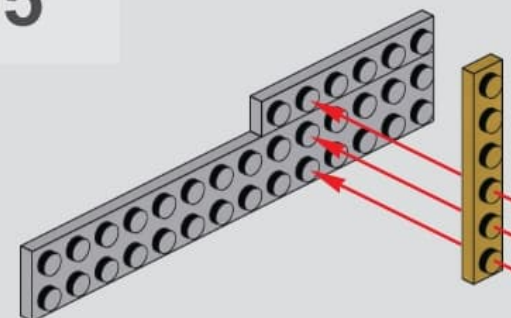
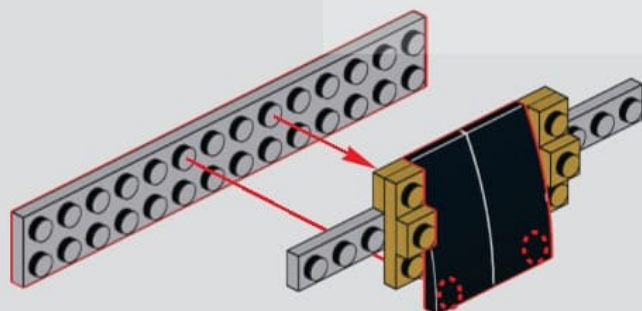

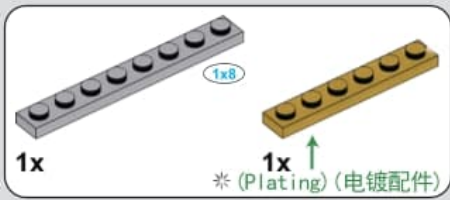

196

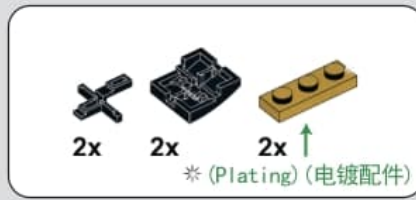
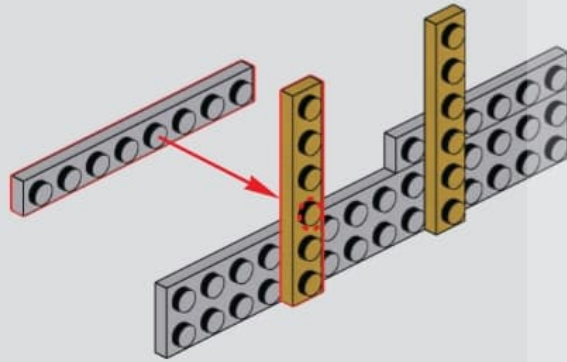

197

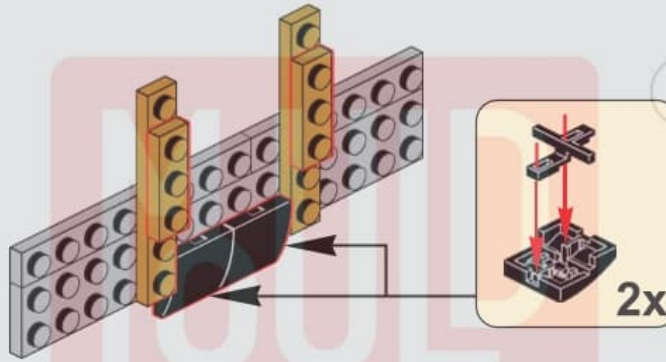

198

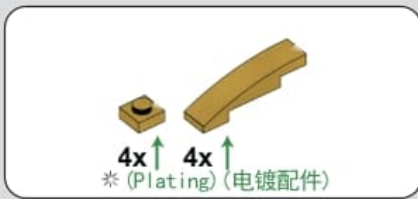
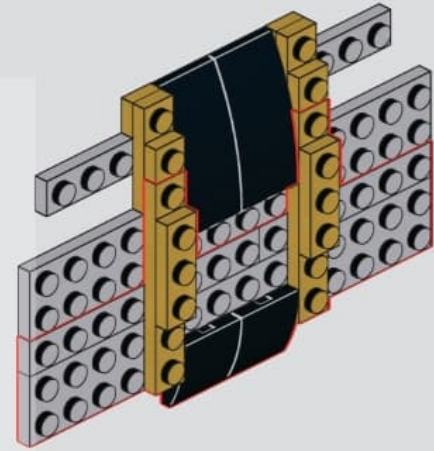

199

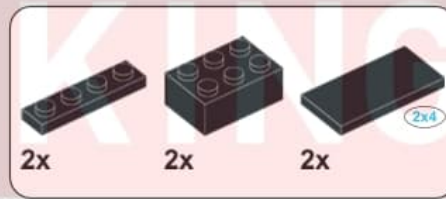
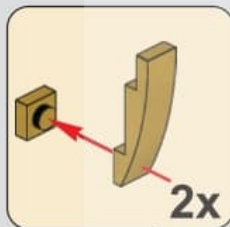
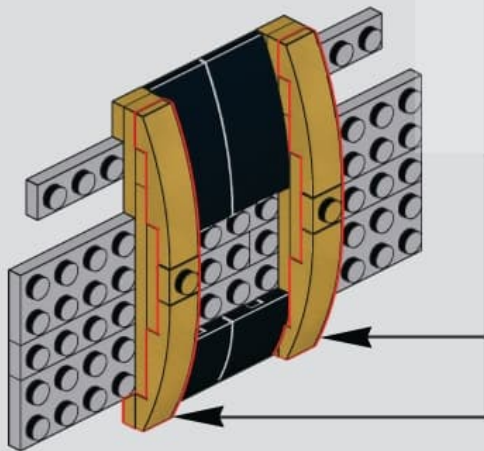

200

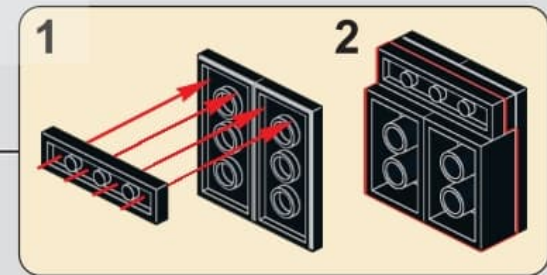
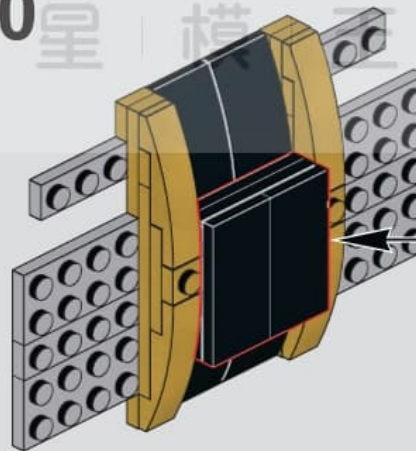



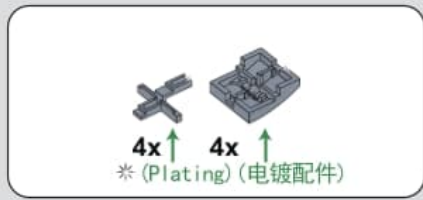

201

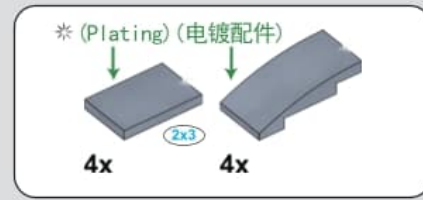
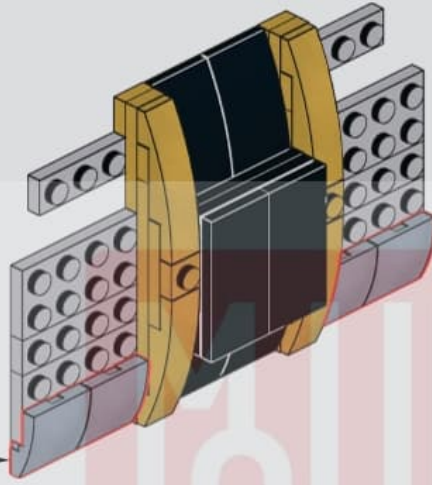
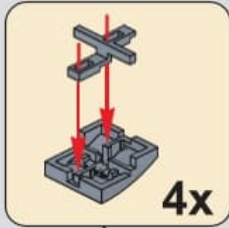

202

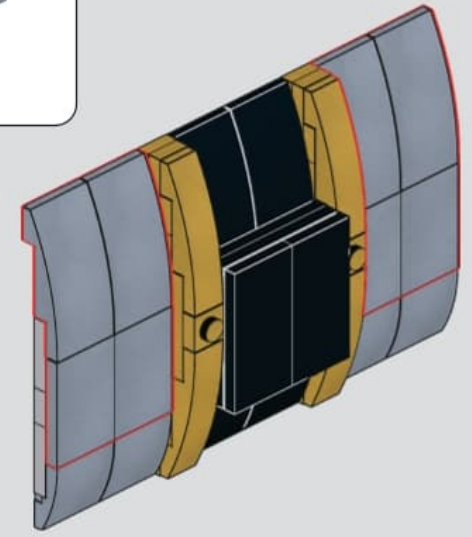

203

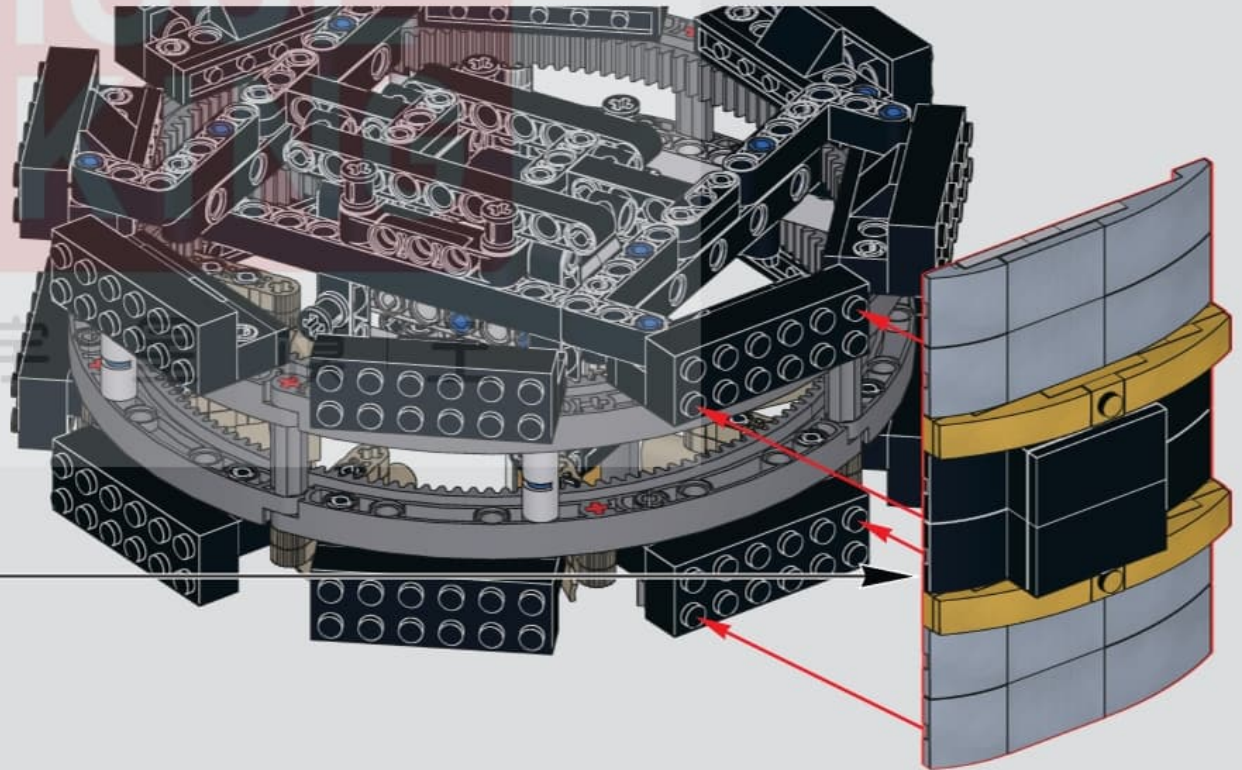
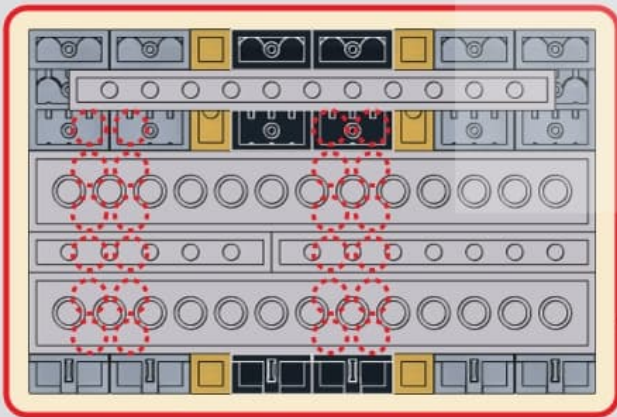

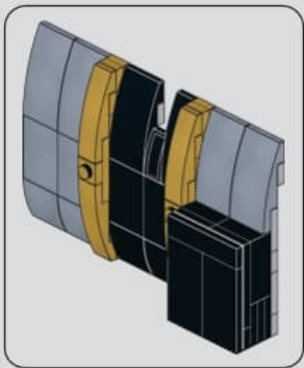

204

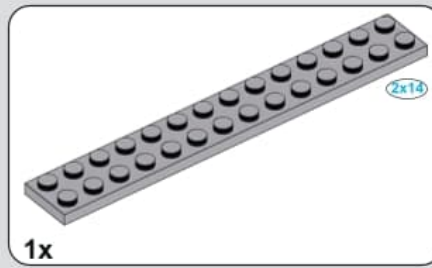

205



206

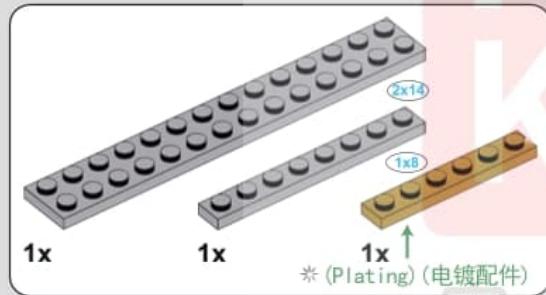
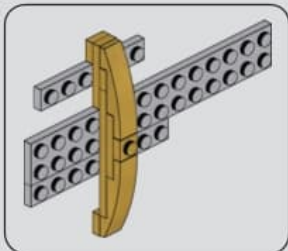
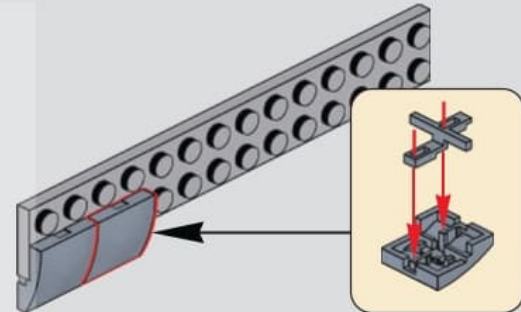
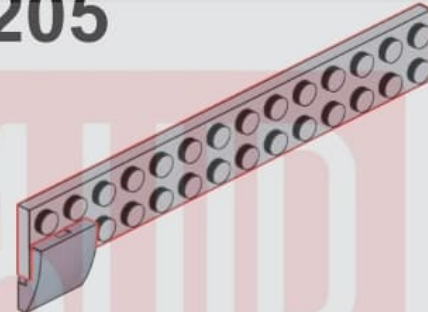
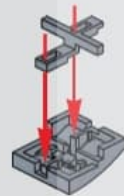

207



208

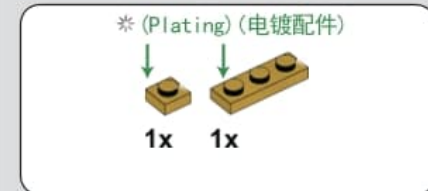

209

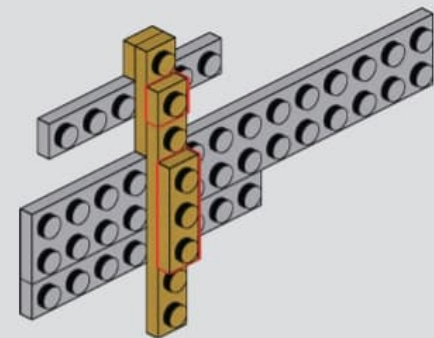
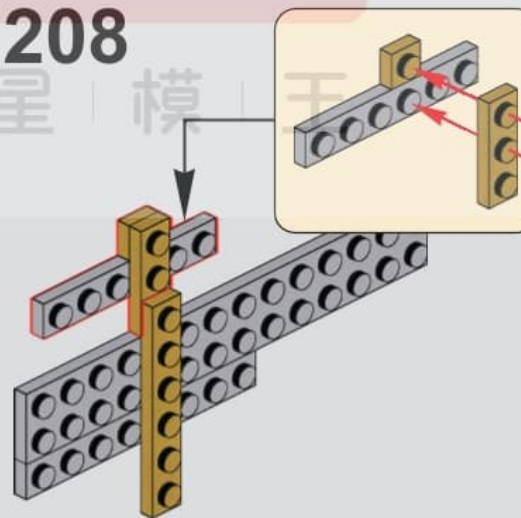
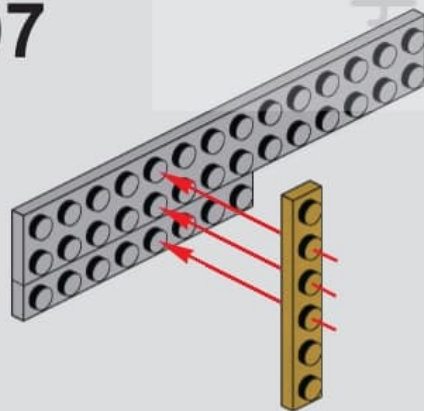



# 211

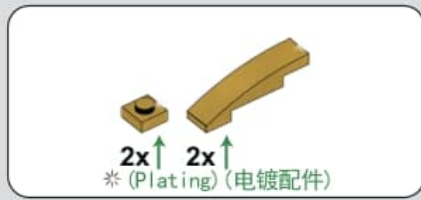

## 210

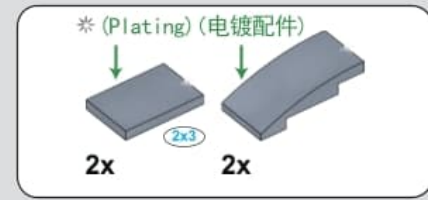
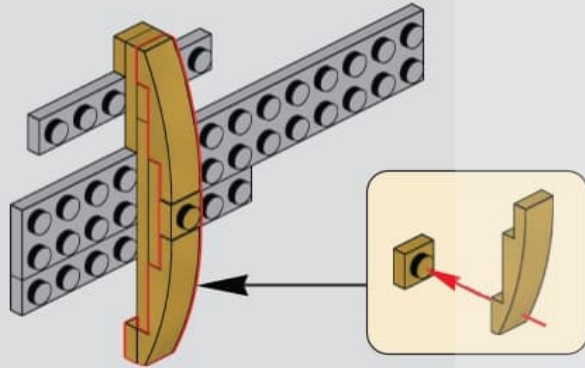

## 212

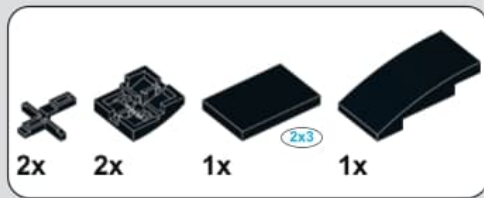
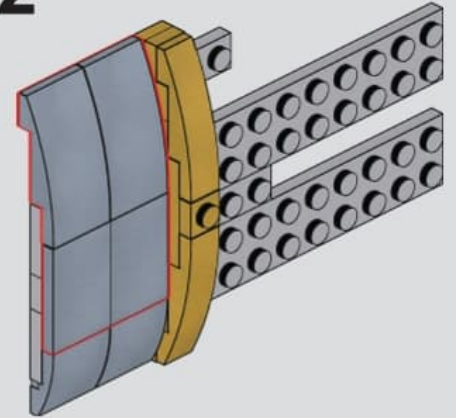

## 213

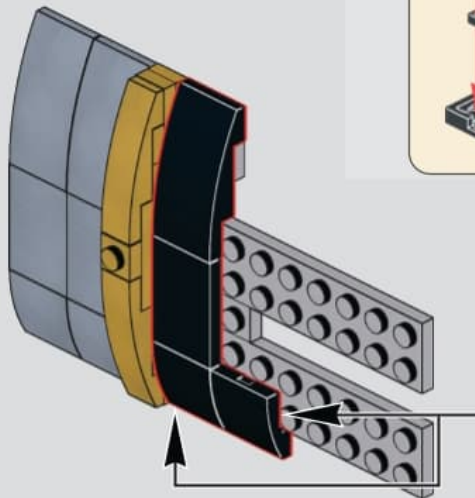

## 214

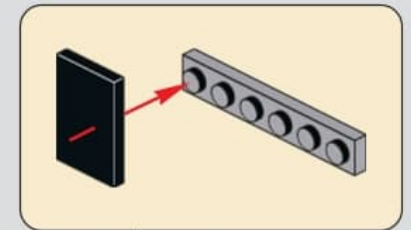
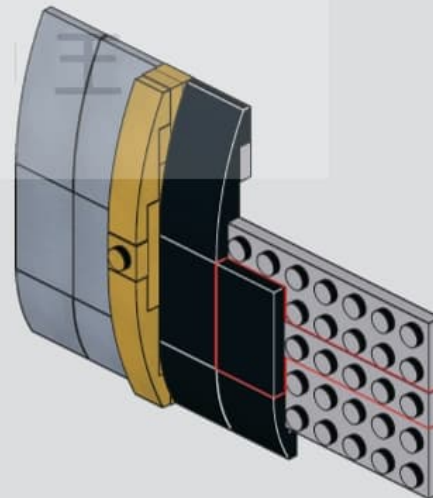

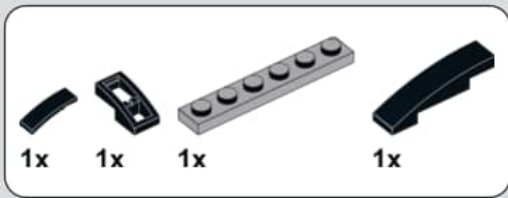

215

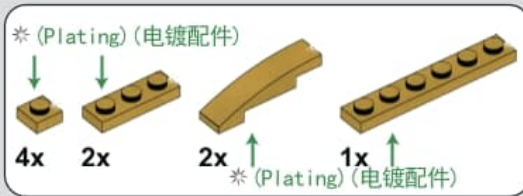
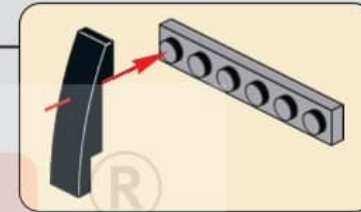
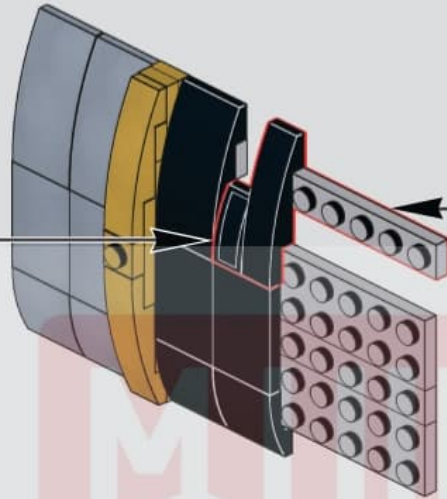

216

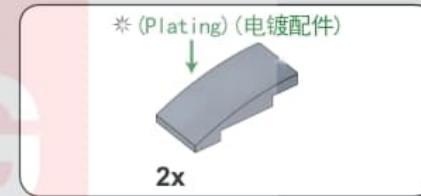
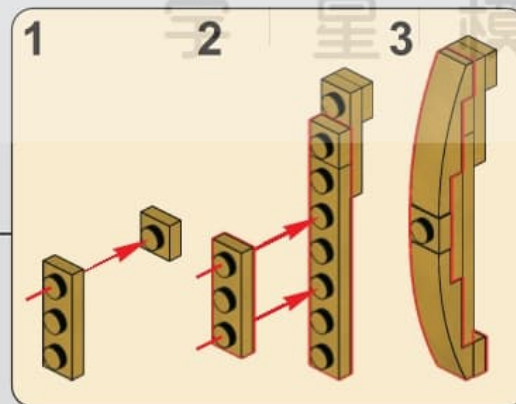
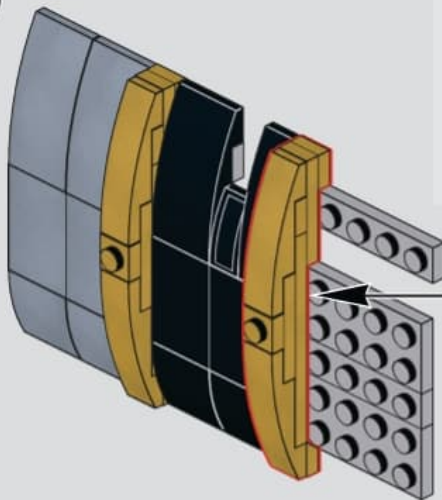

217

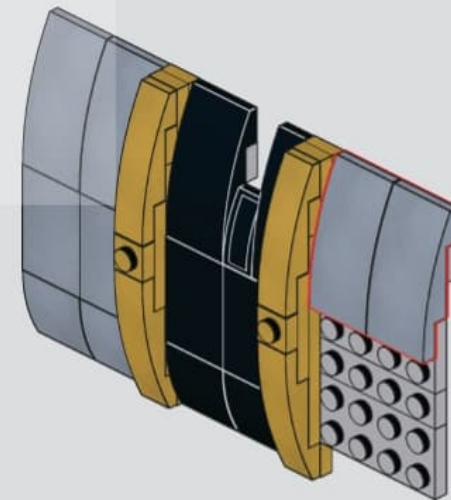



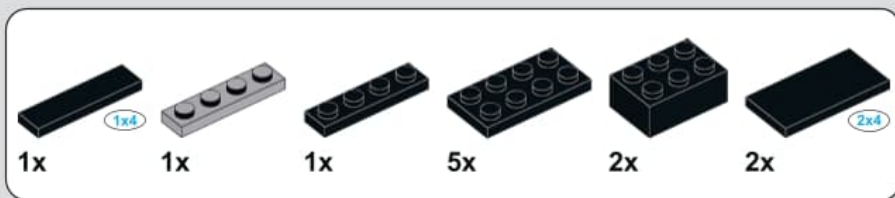

# 218

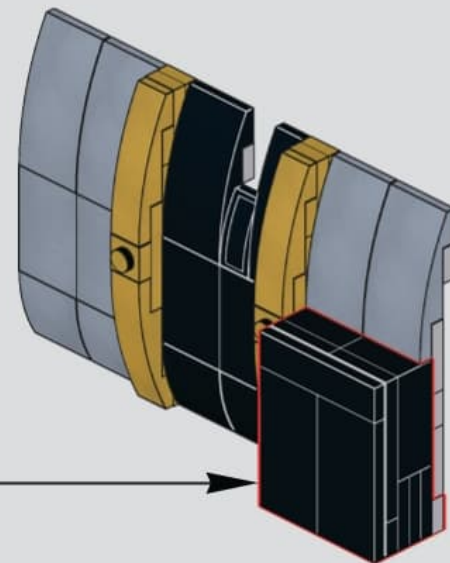
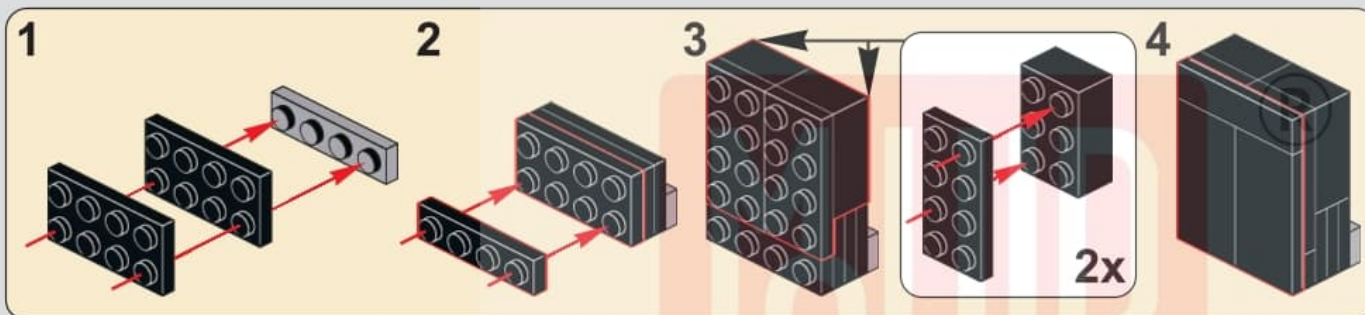

# 219

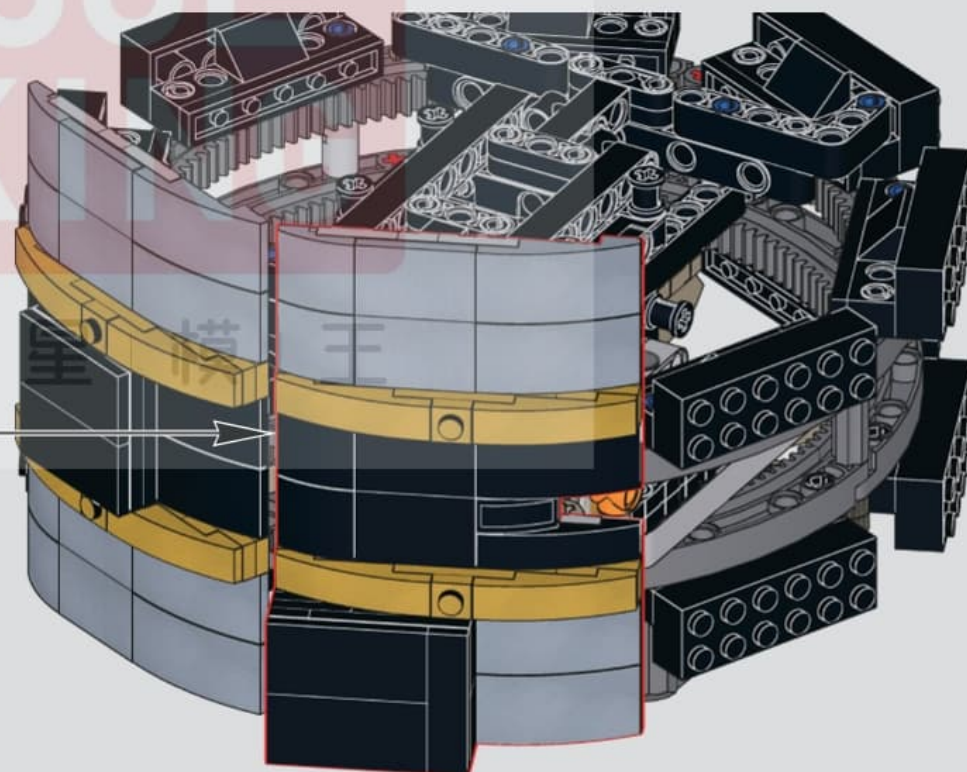
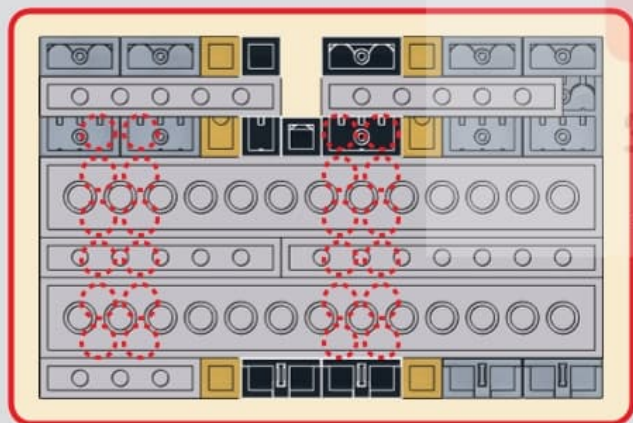

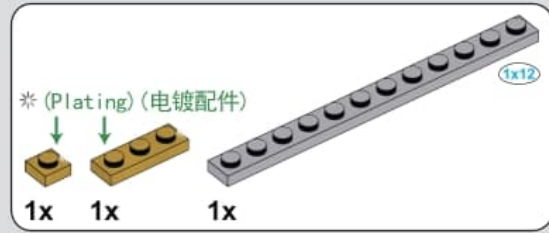
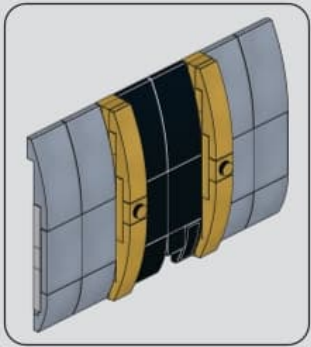

220

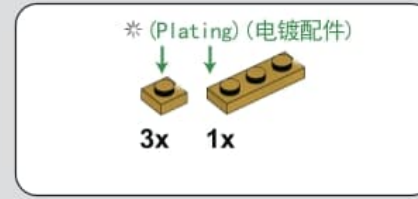

221

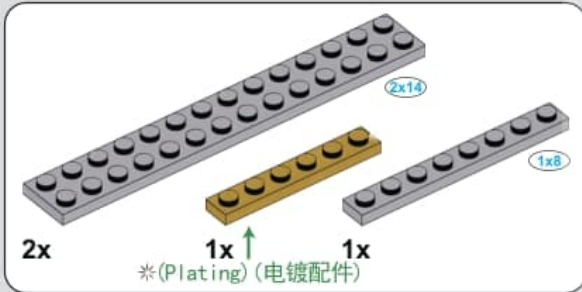

222

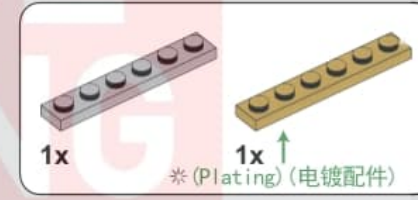

223

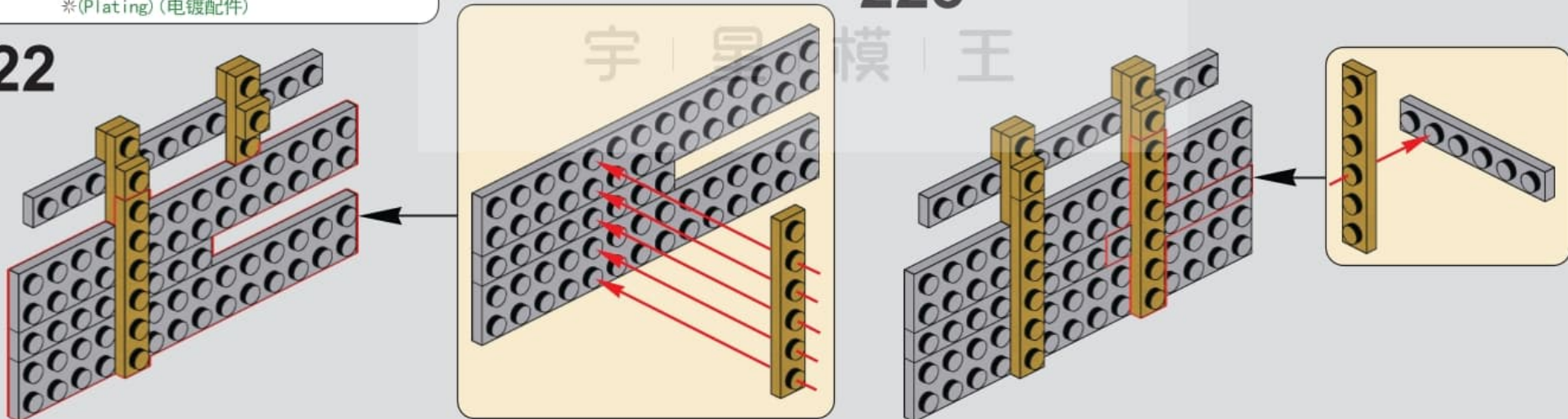



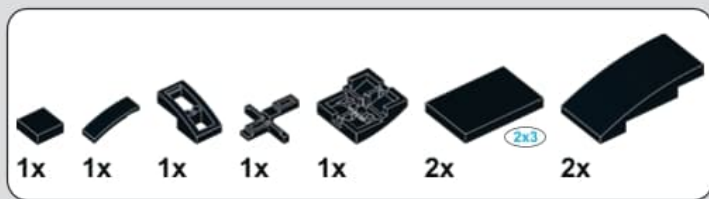

224

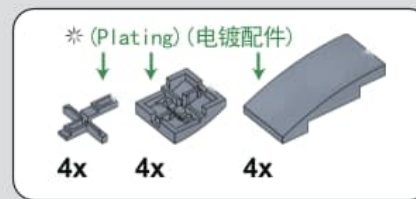
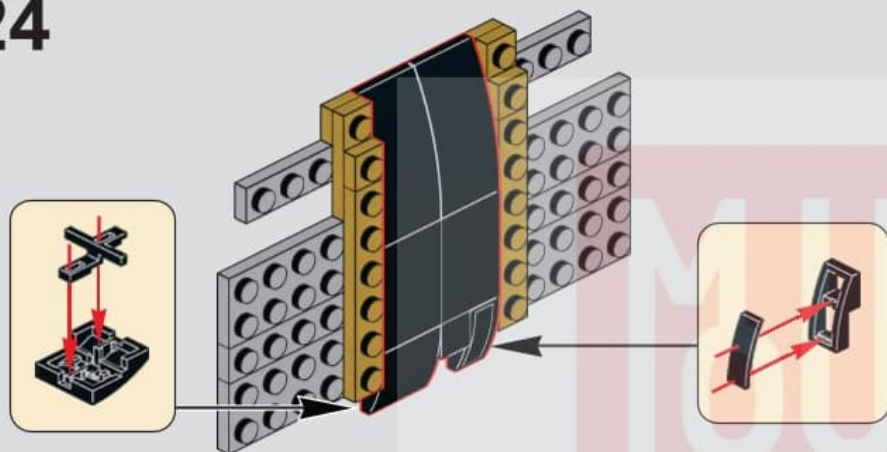

225

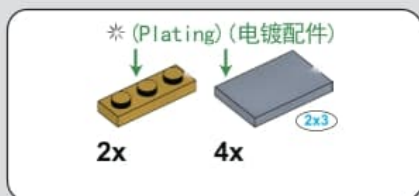
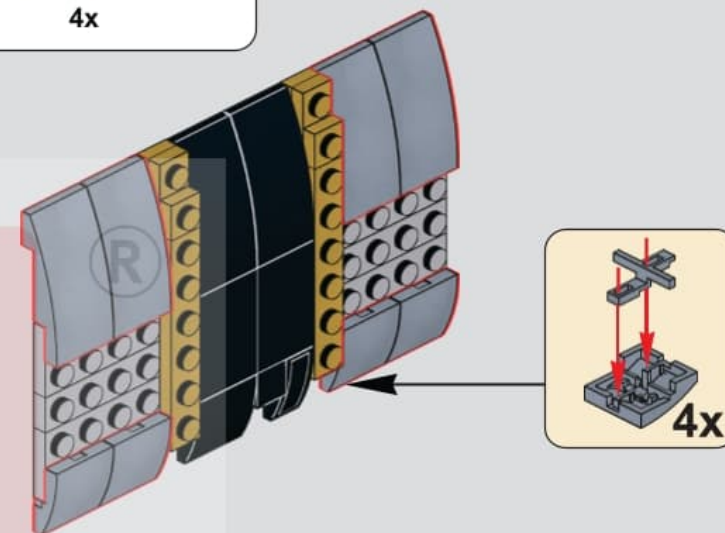

226

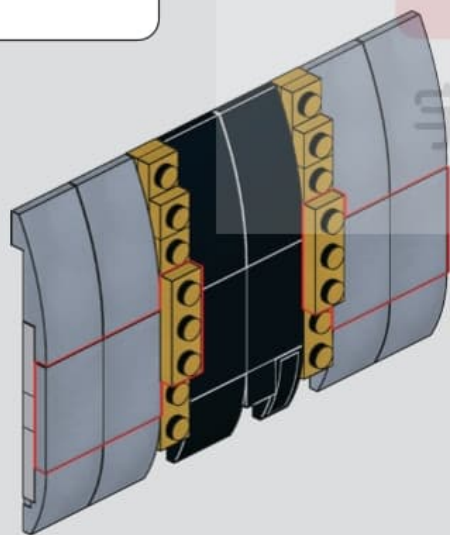

227

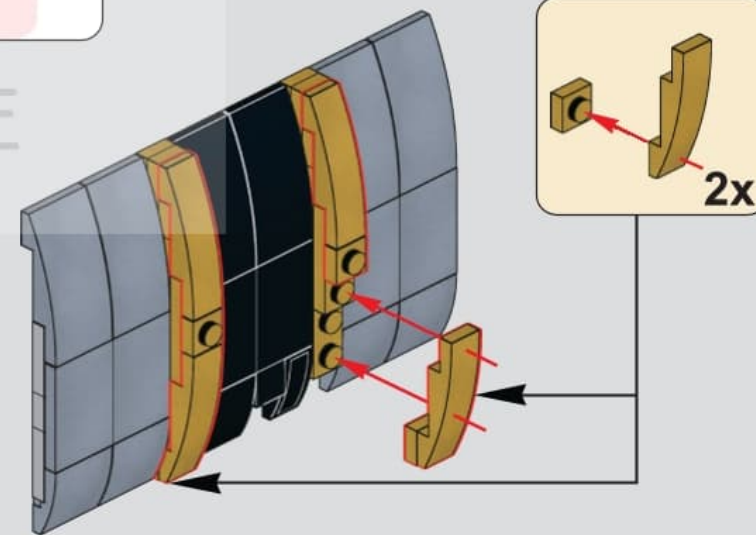

228

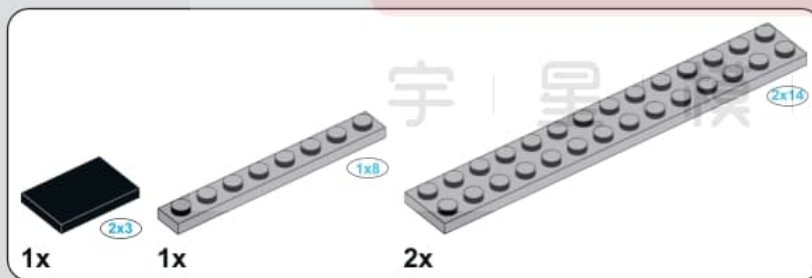
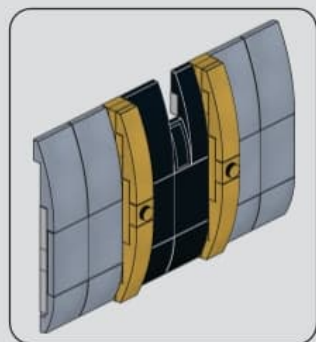
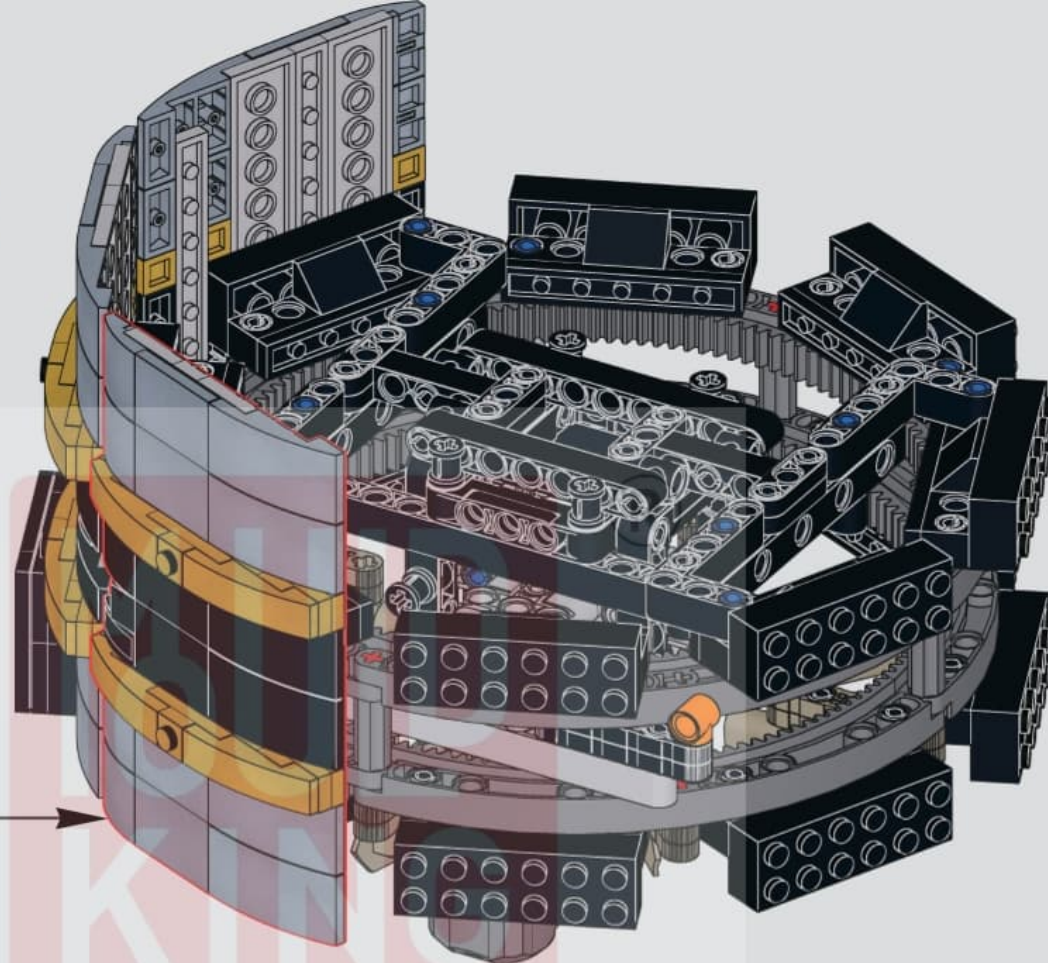
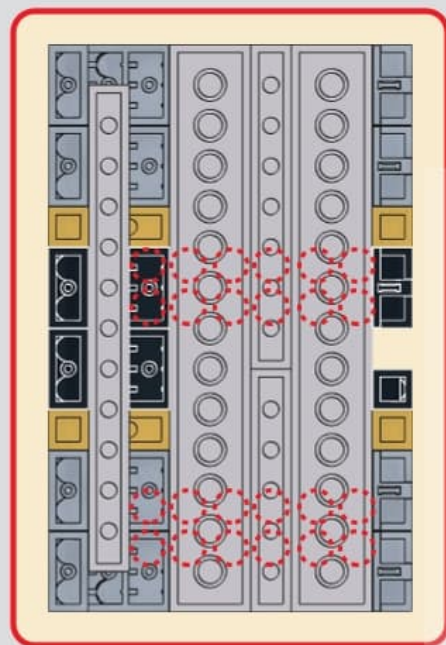

229

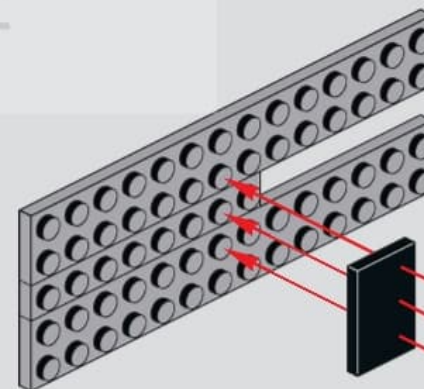



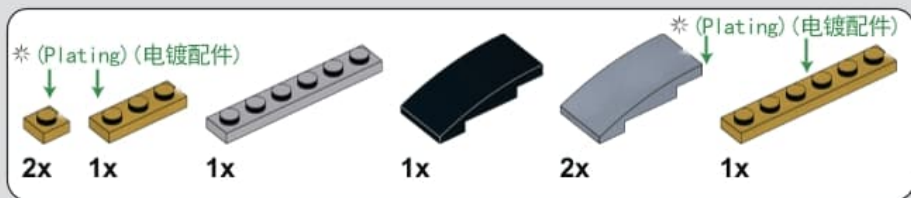

230

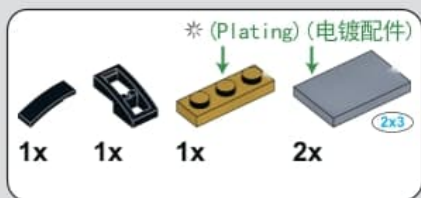
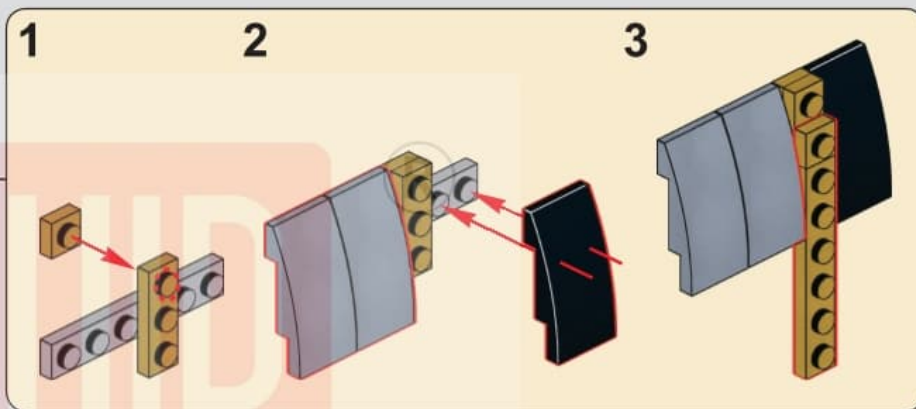
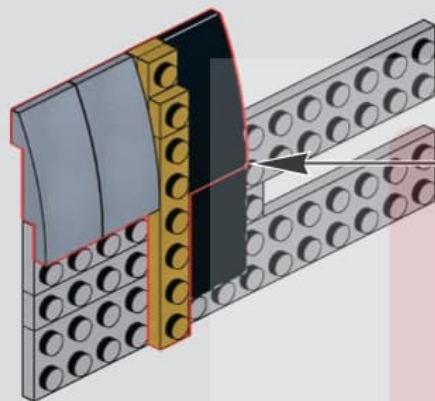

231

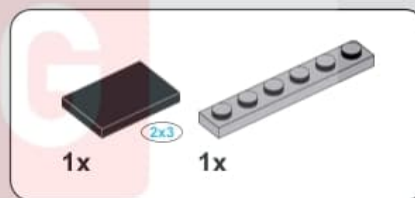
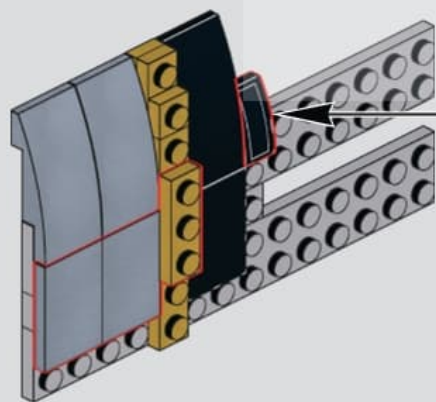

232

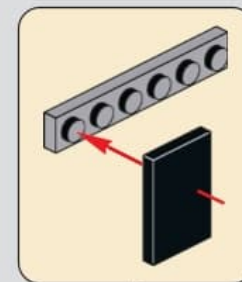
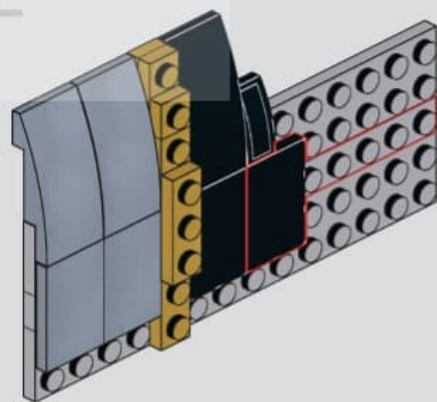

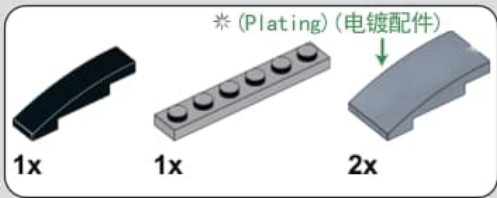

233

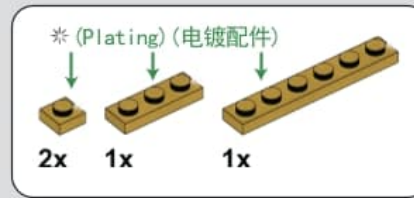
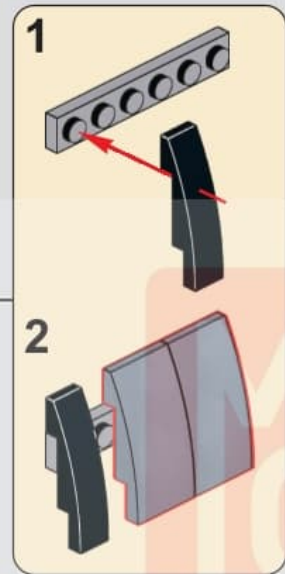
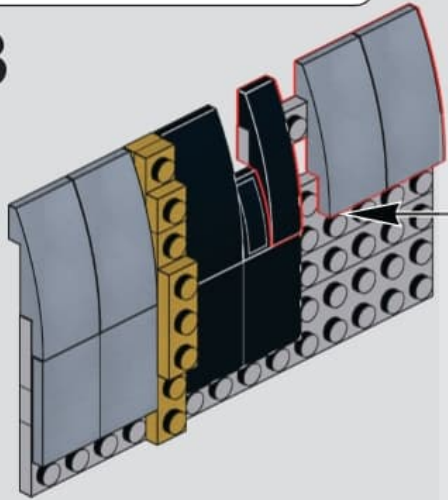

234

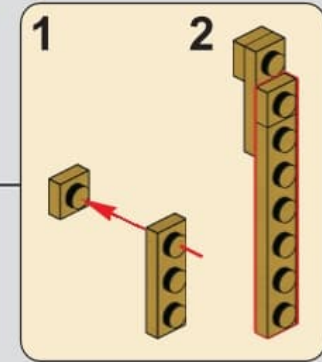
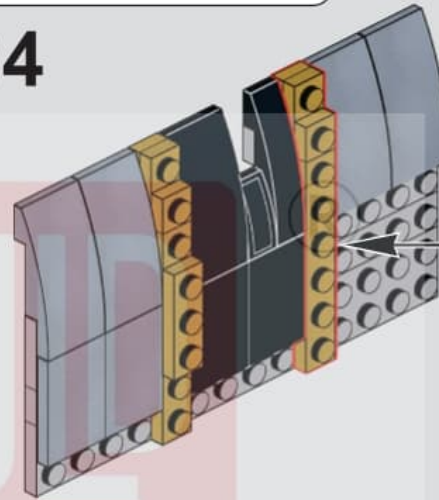

235

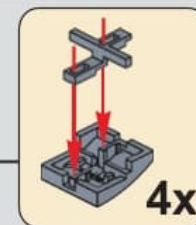
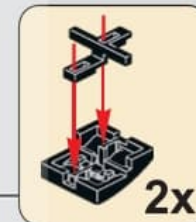
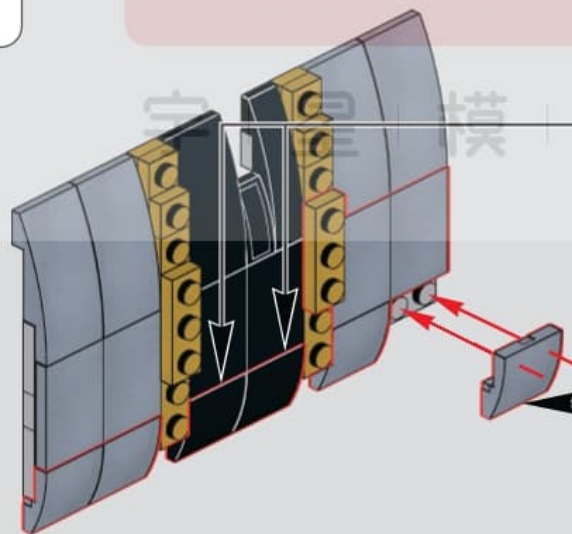



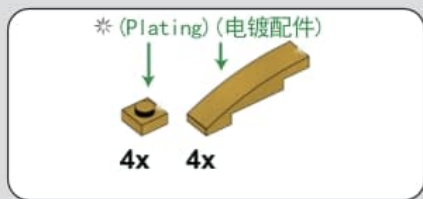

236

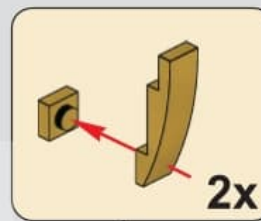
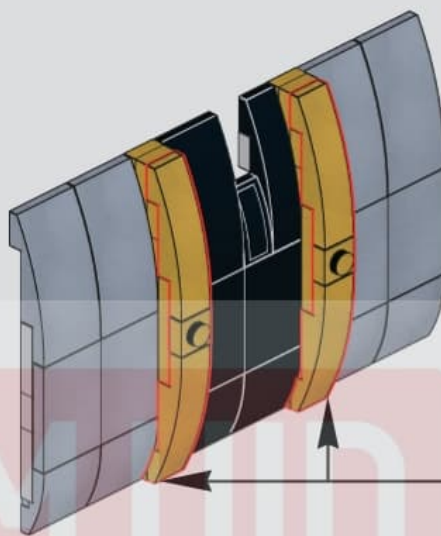

237

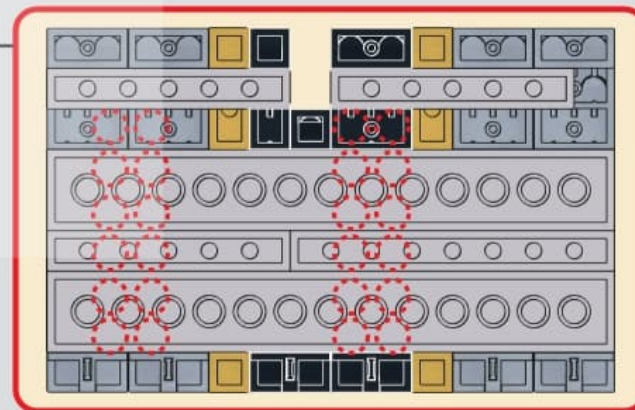
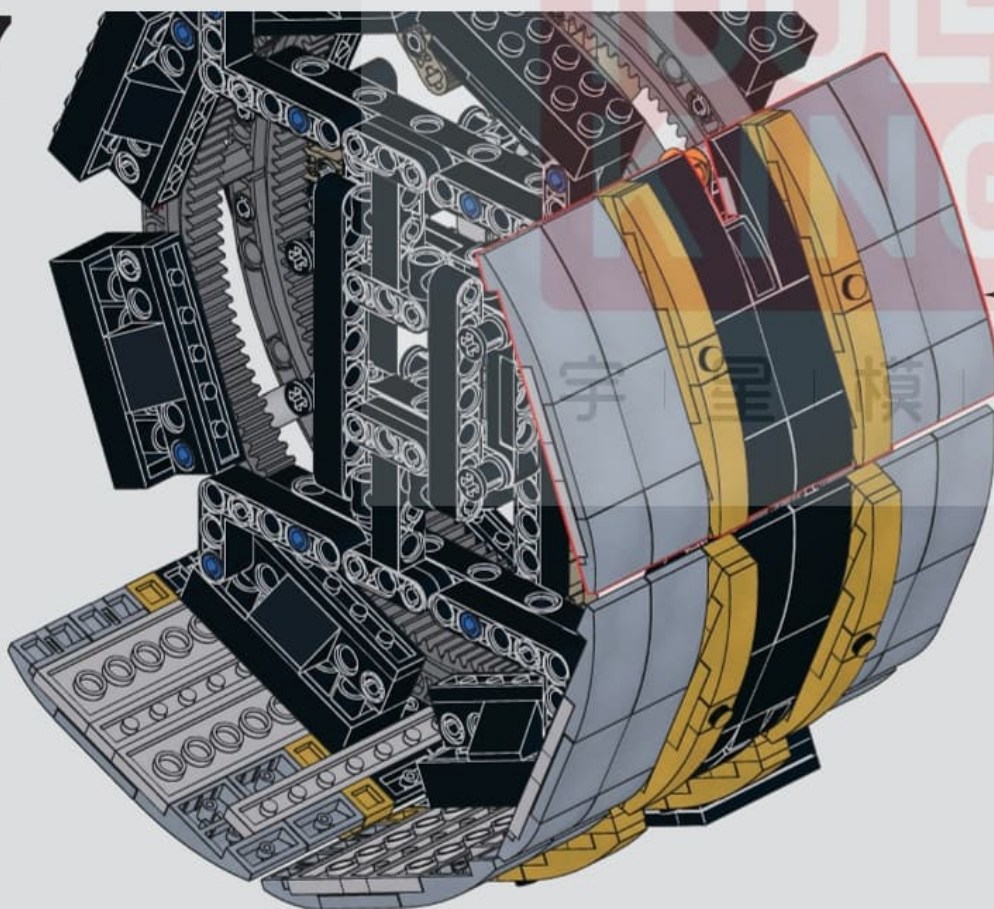





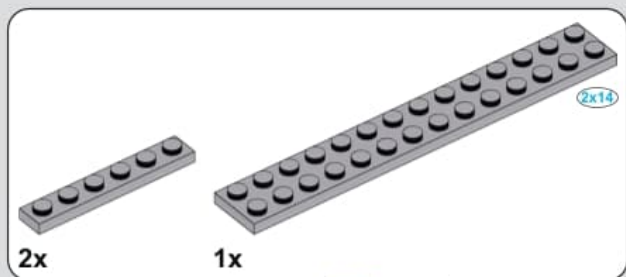

242

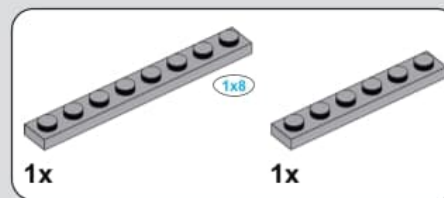
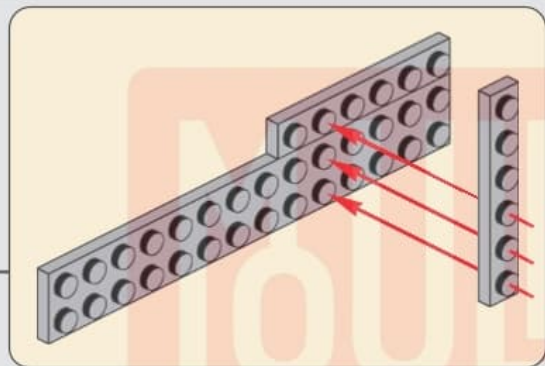
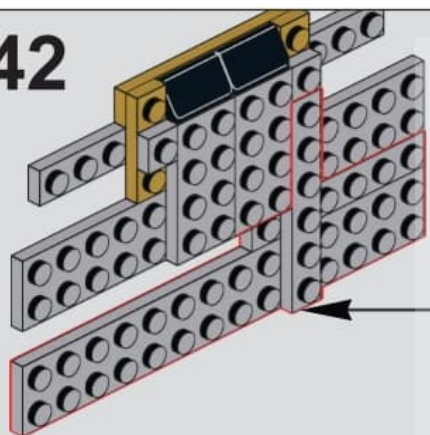

243

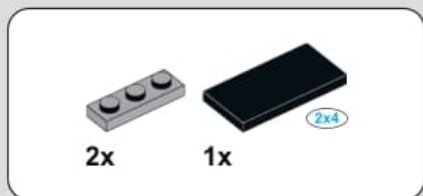
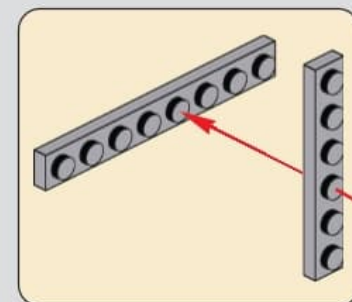
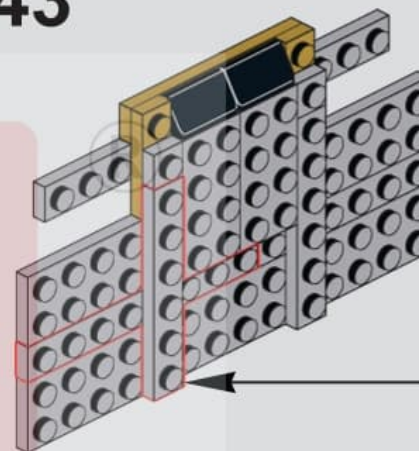

244

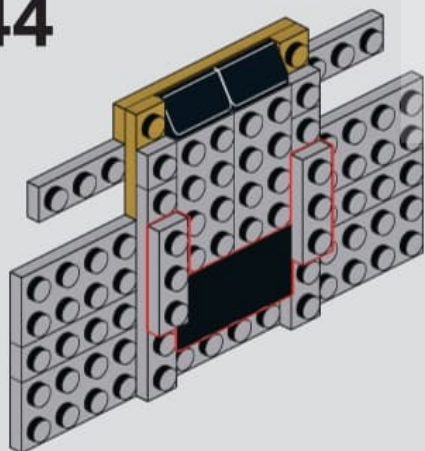

245

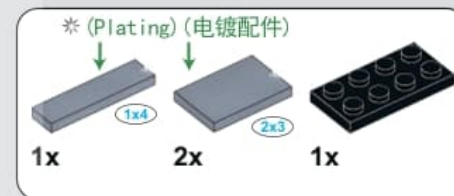
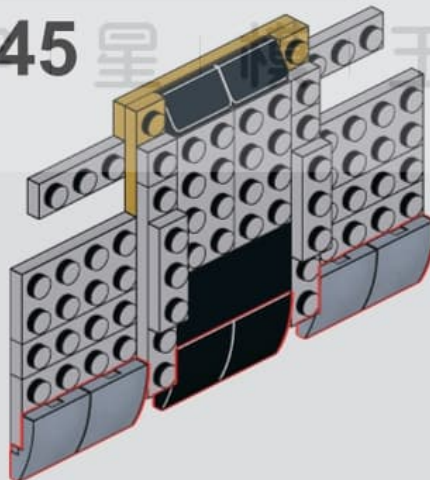

246

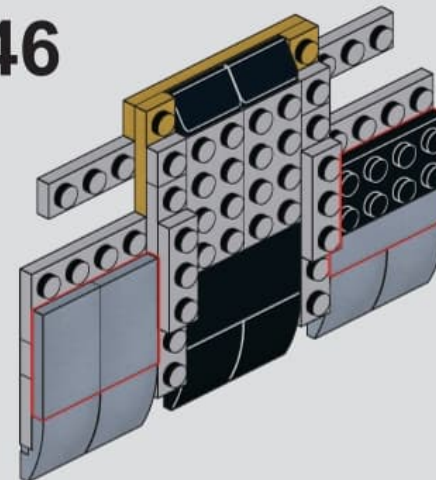

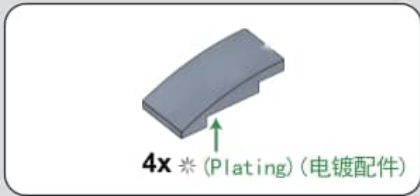

247

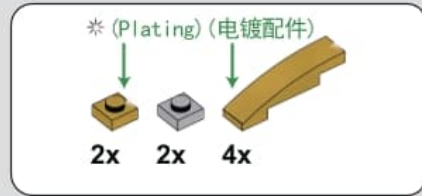
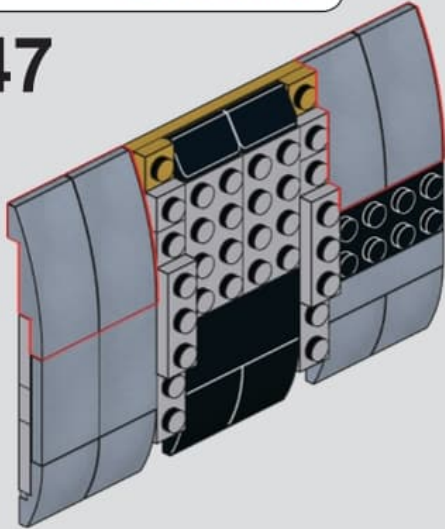

248

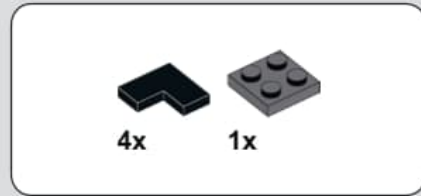
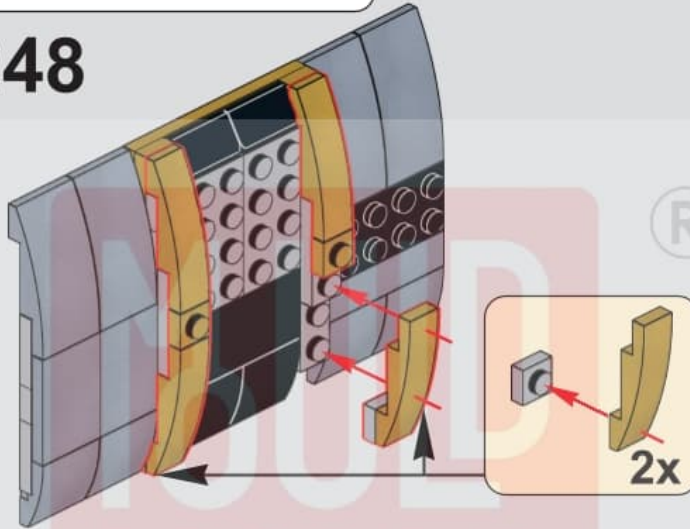

249

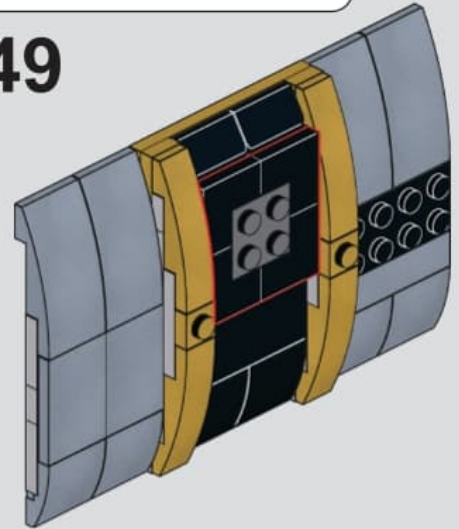

250

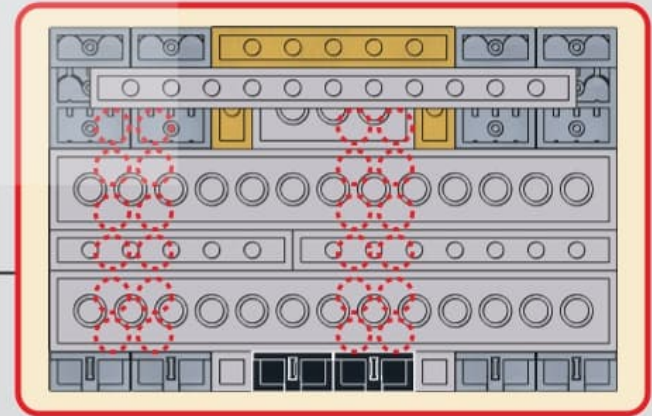
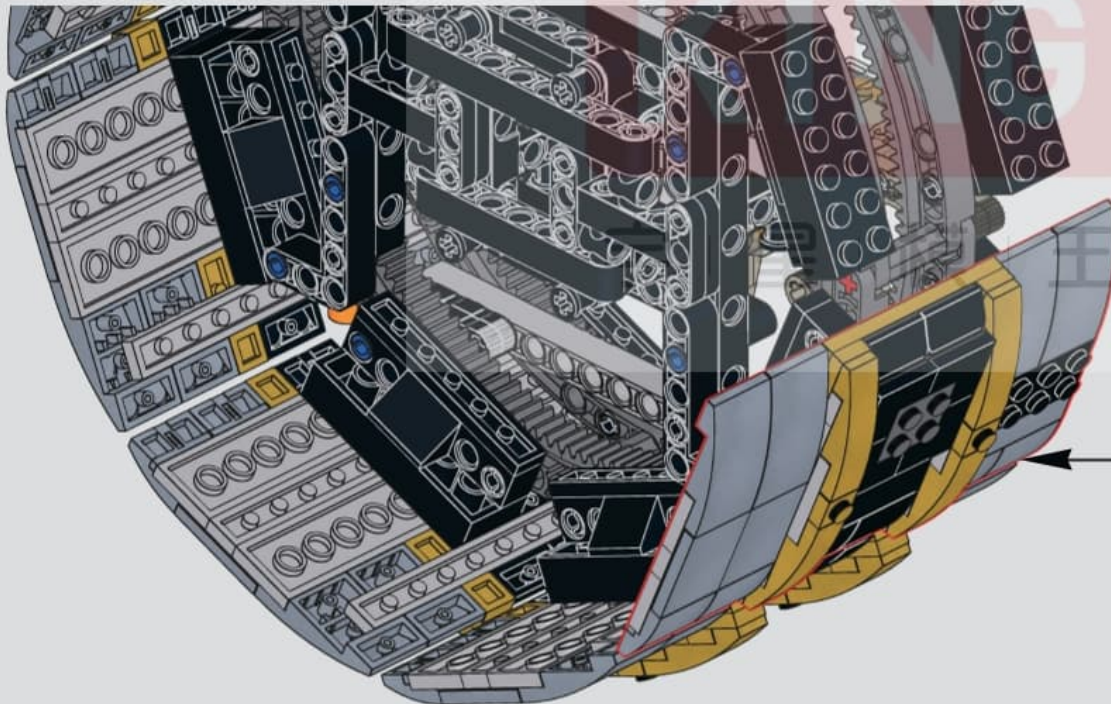



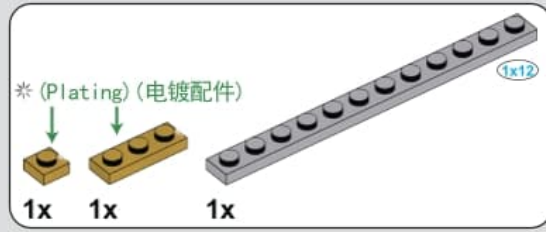
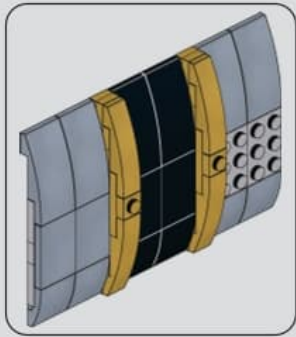

251

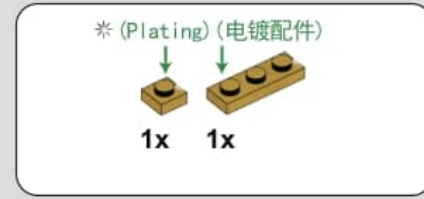
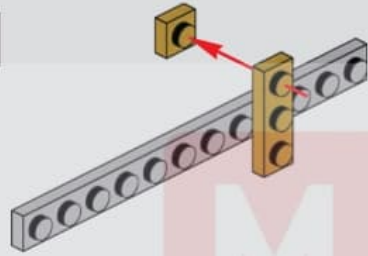

252

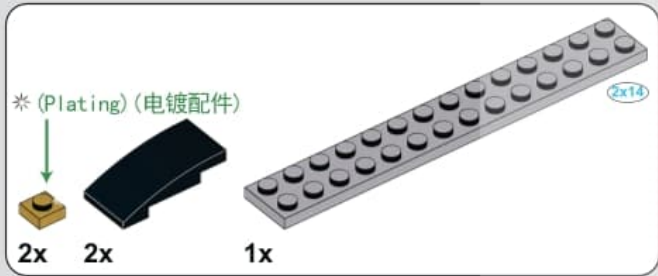
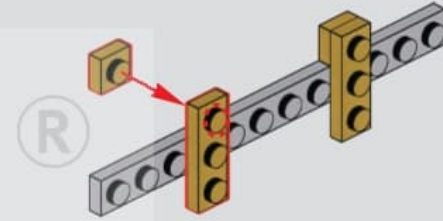

253

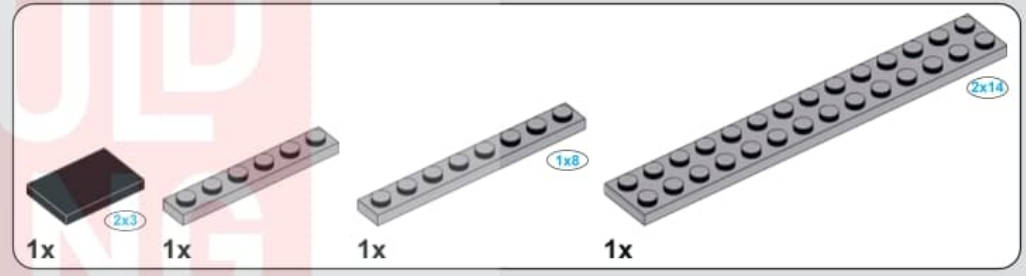
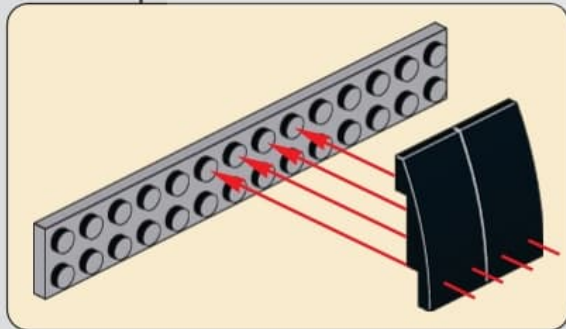
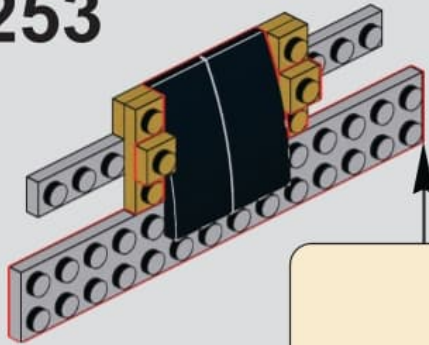

254

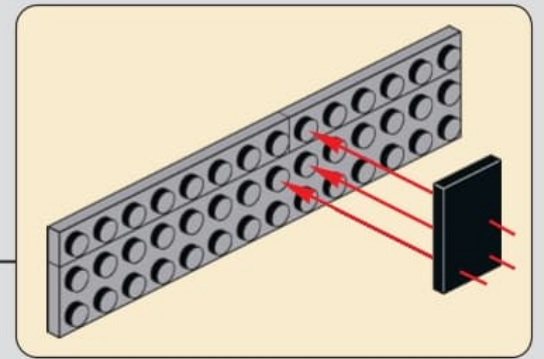
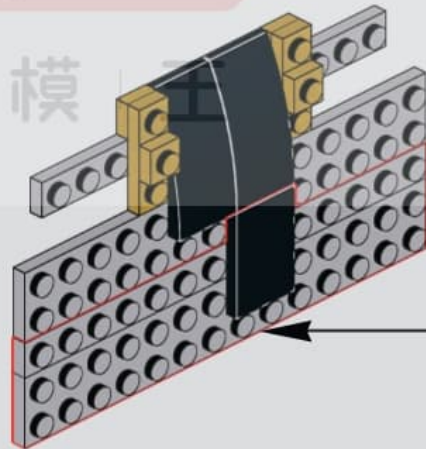

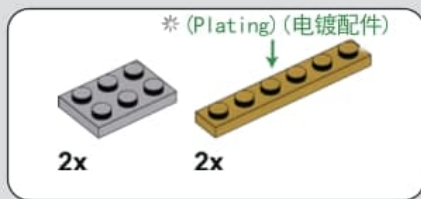

255

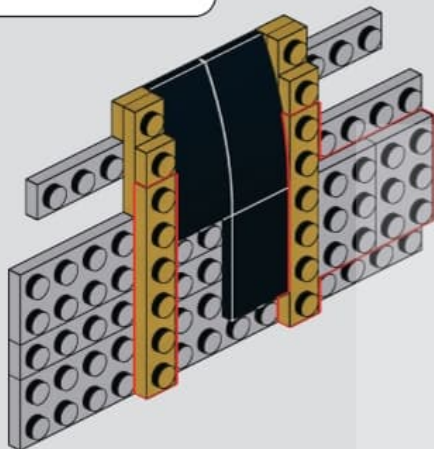

256

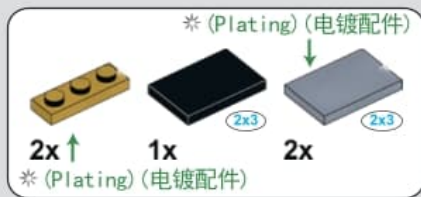
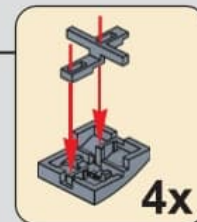
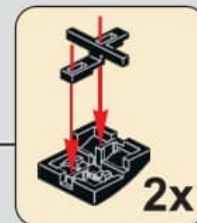
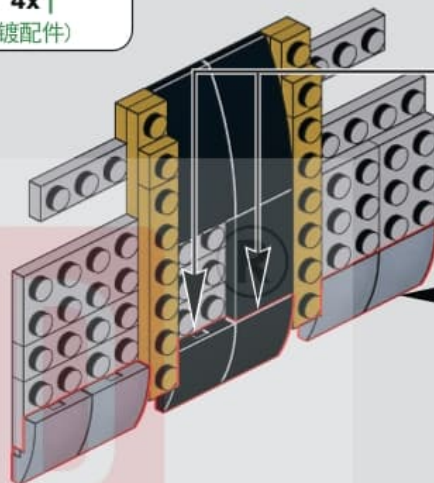

257

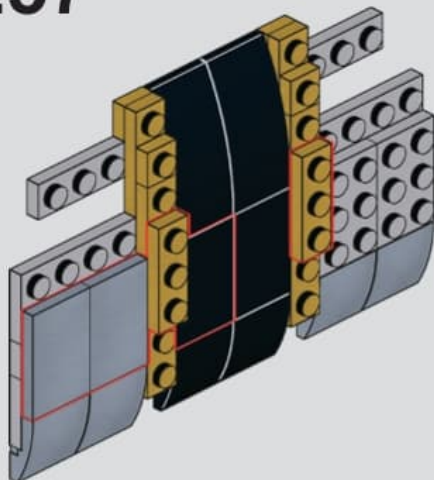

258

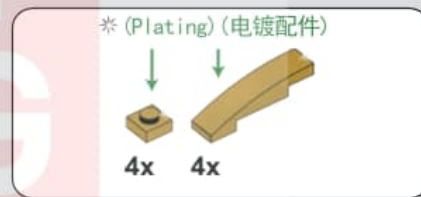
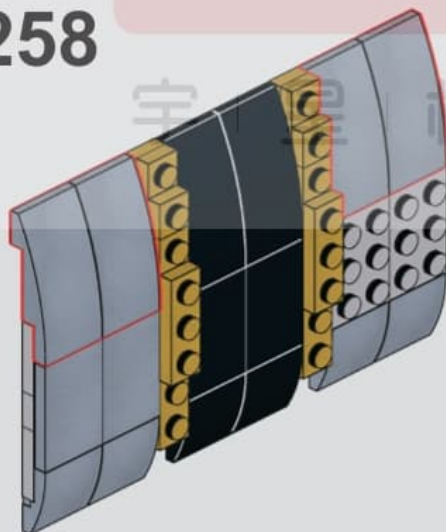

259

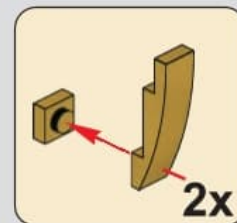
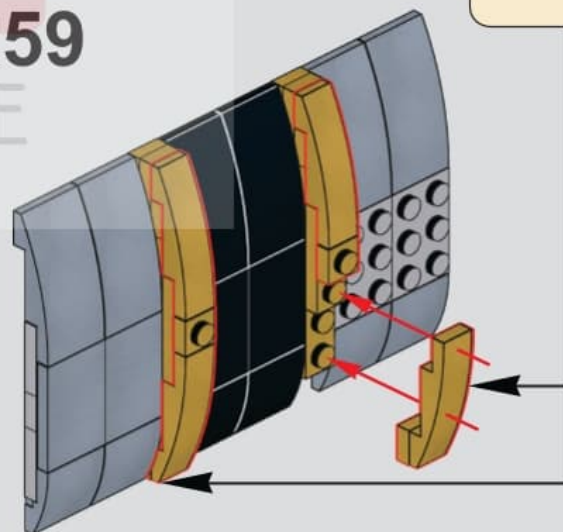



260

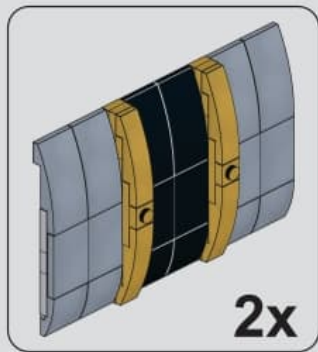
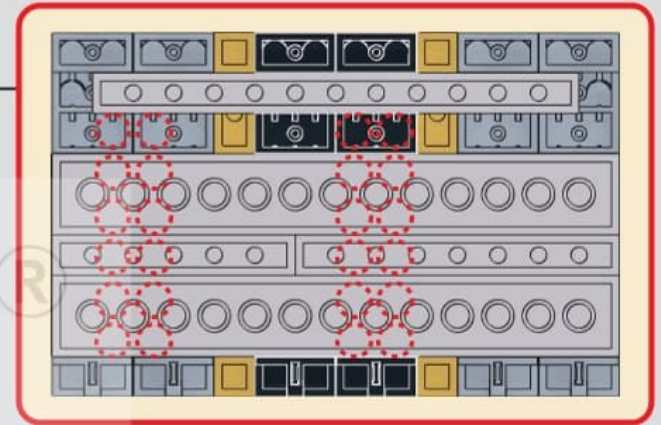
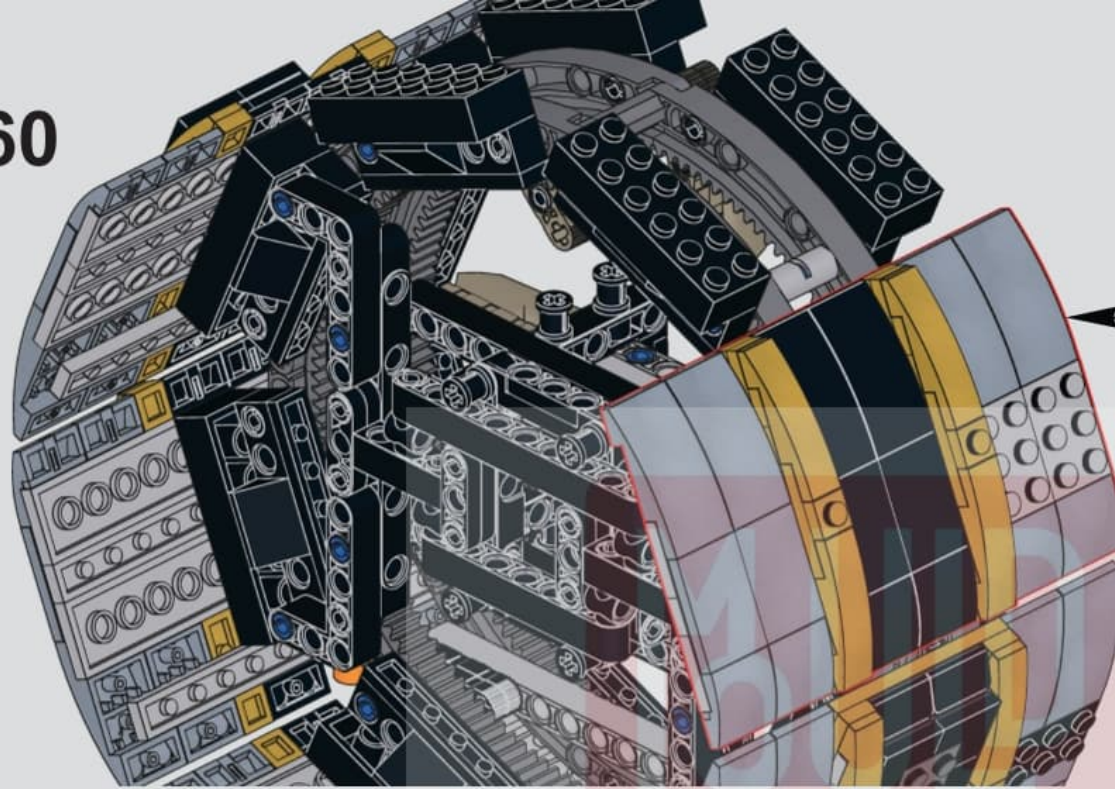

261

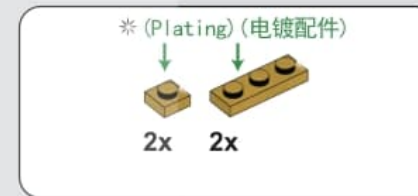

262

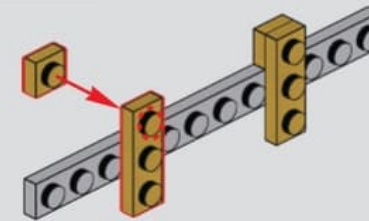
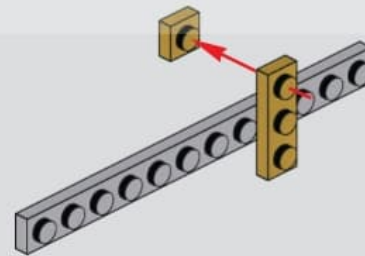

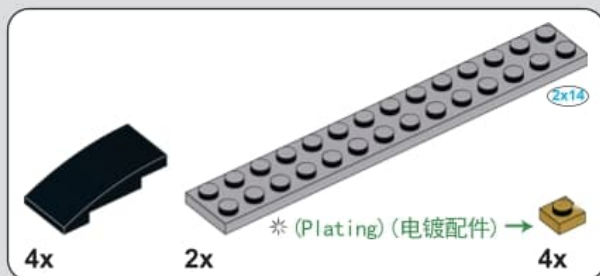

263

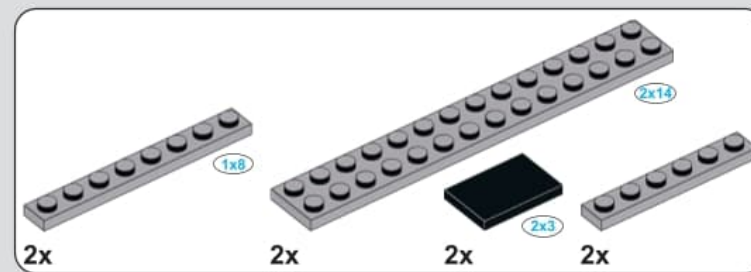

264

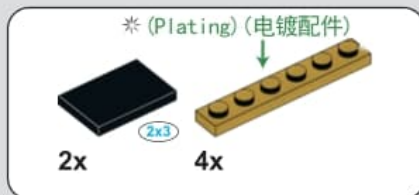
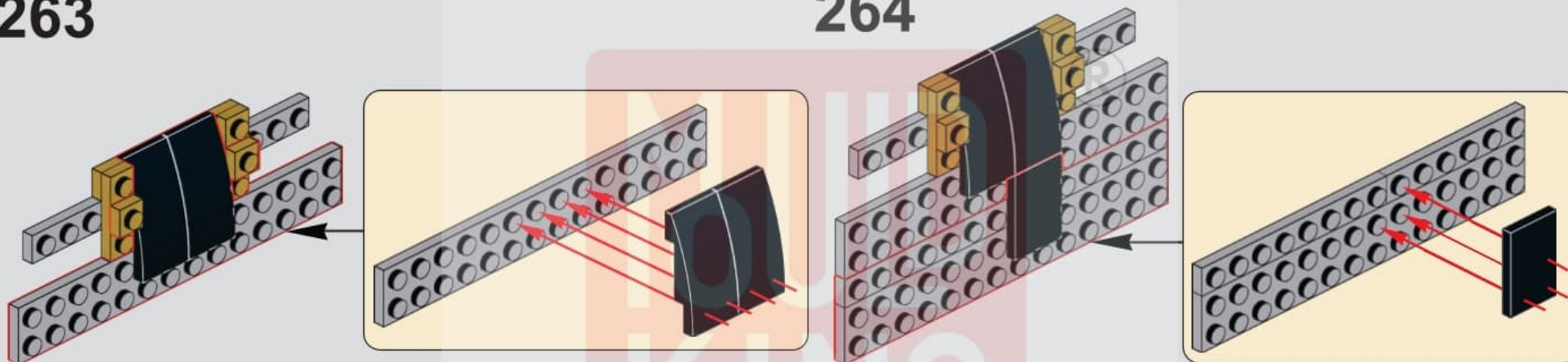

265



266

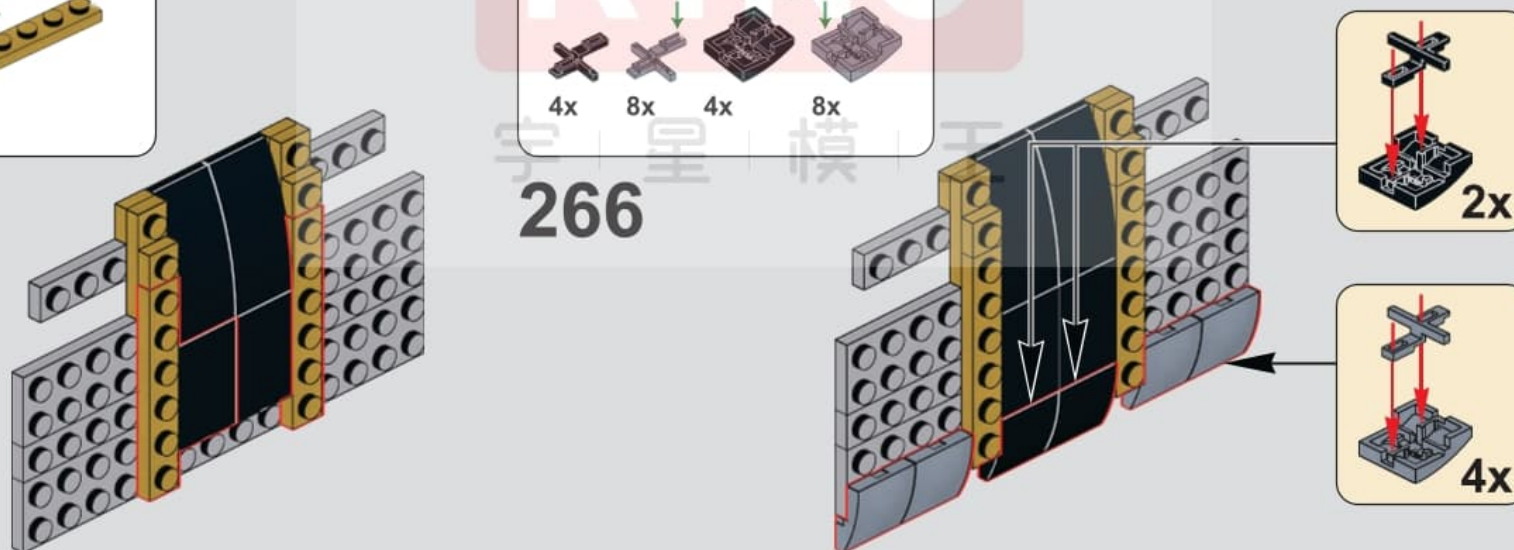



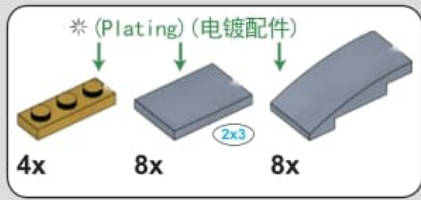

267

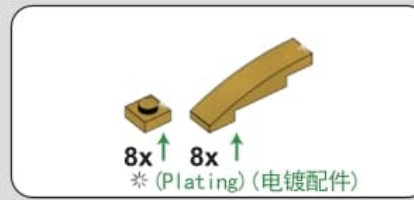
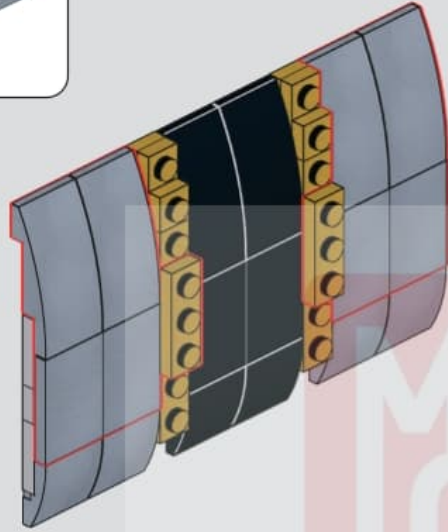

268

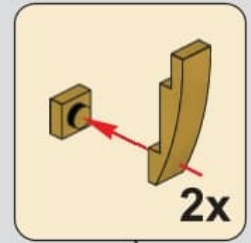
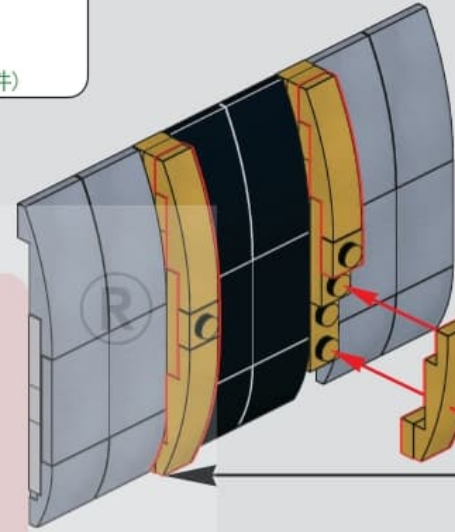

2x

269

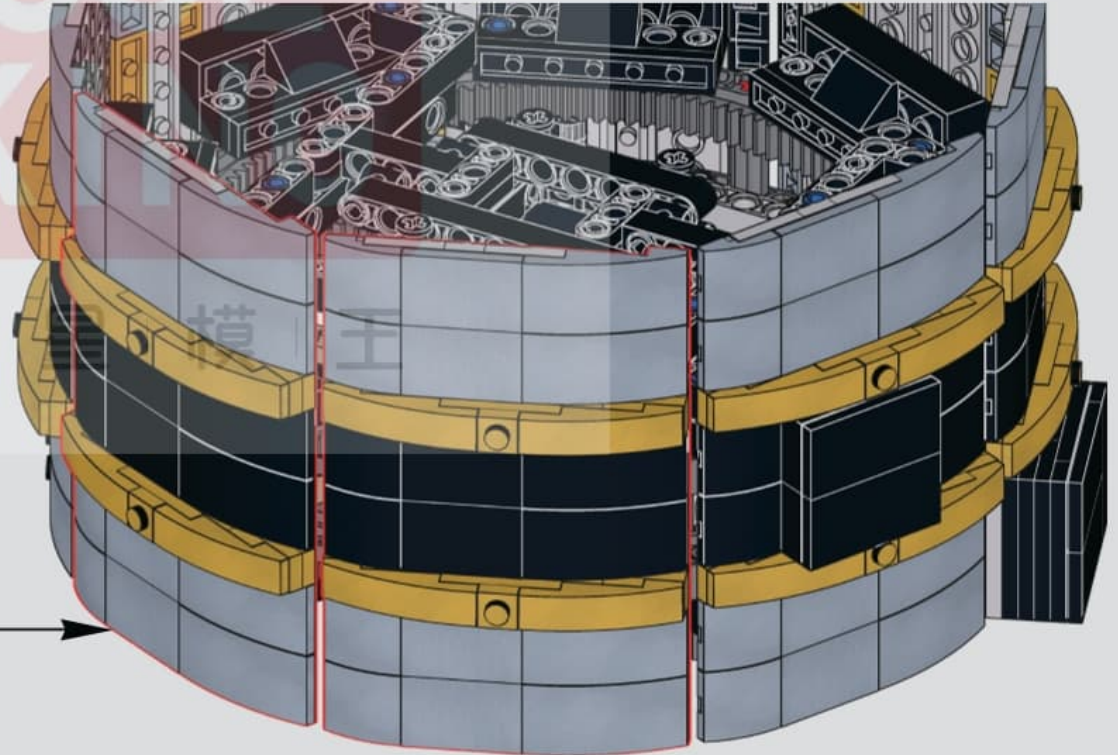
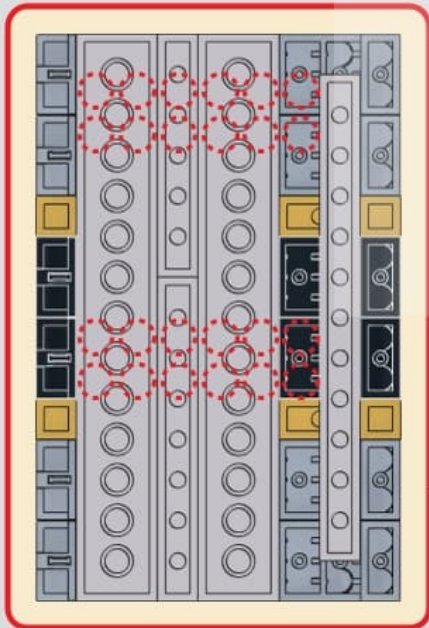

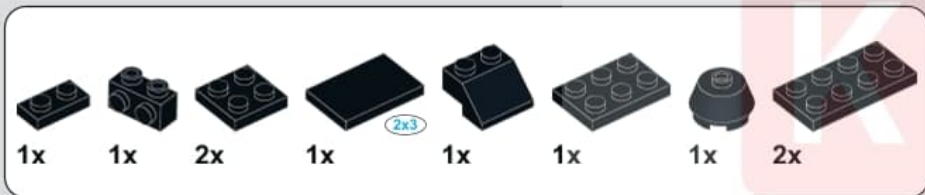
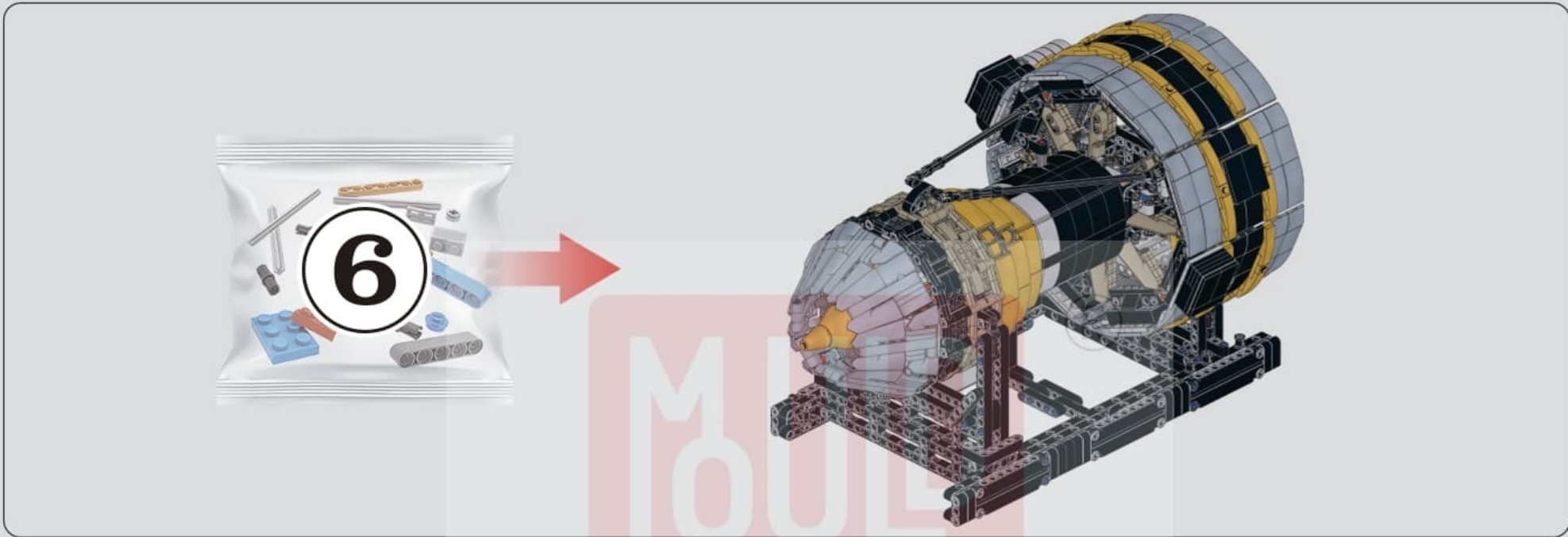

270

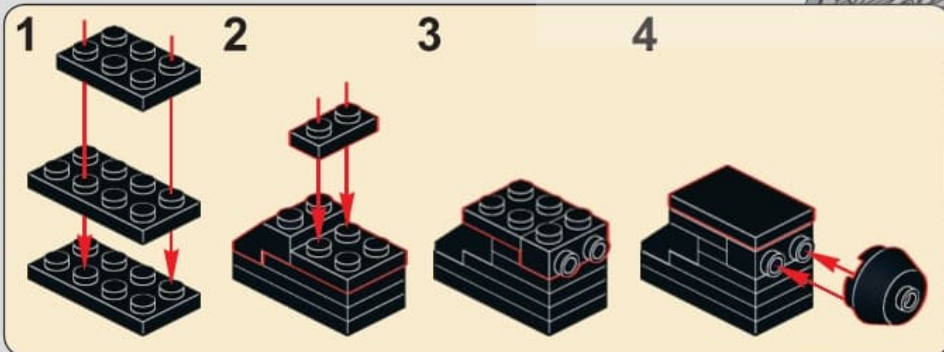



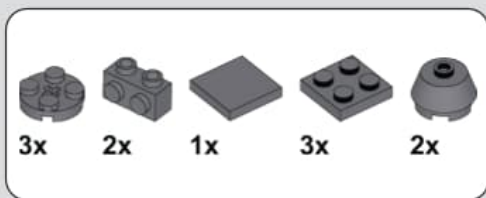

271

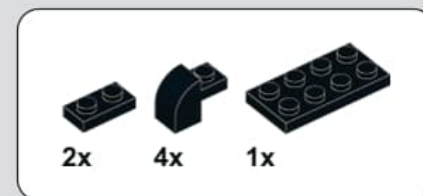
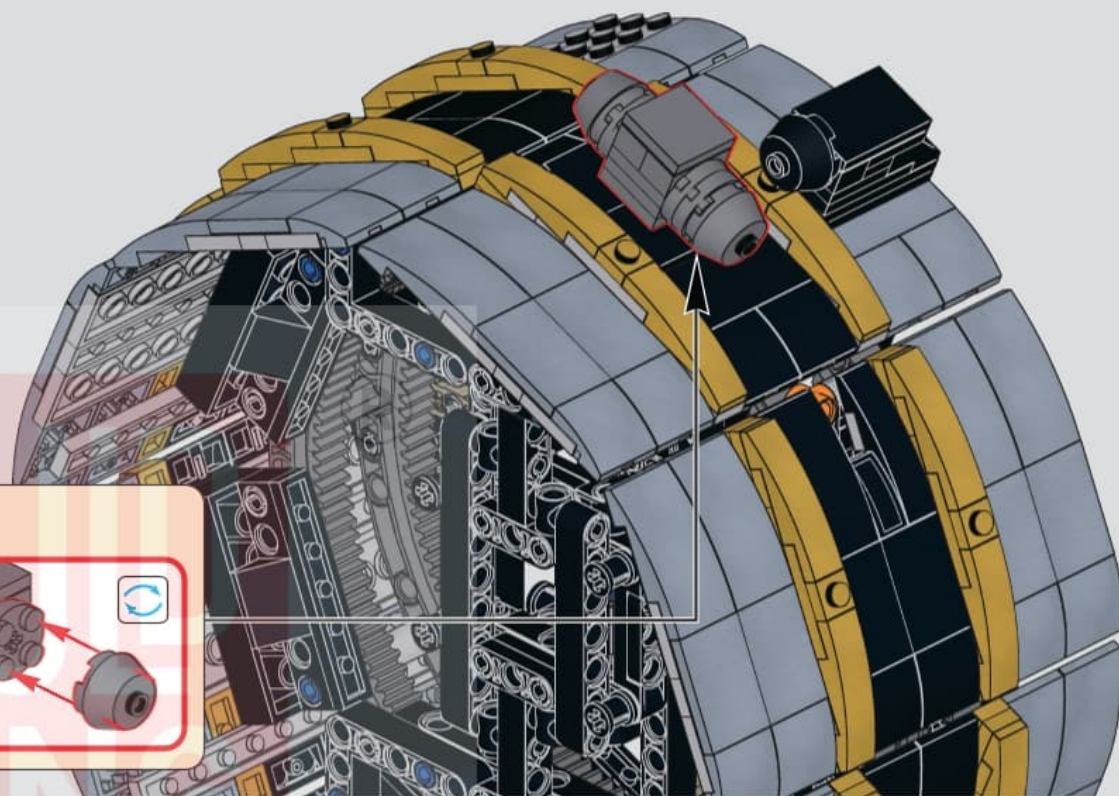
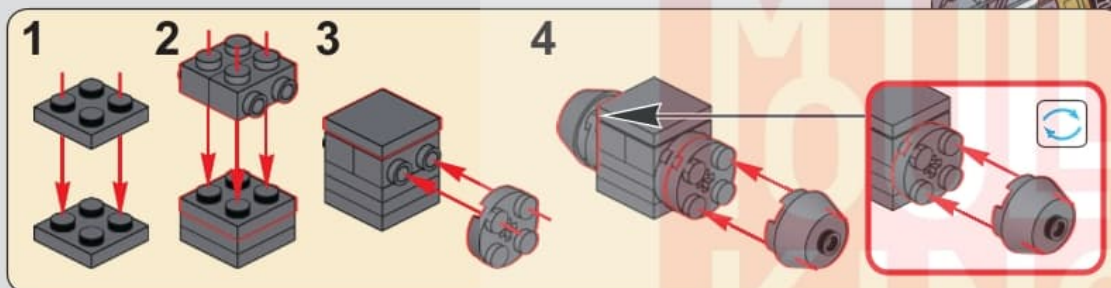

272

273

274

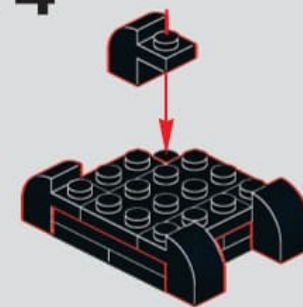
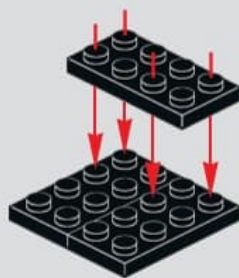

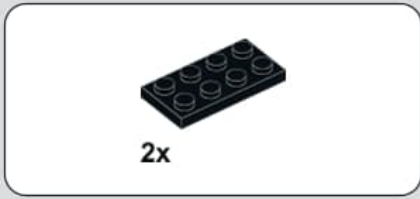

275

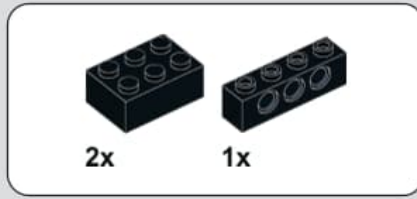

276

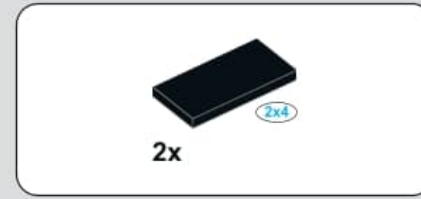

277

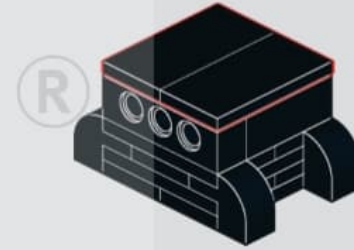
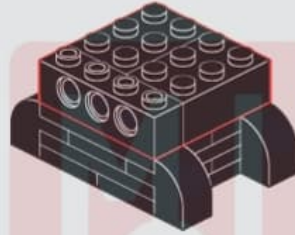
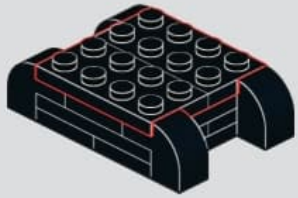

278

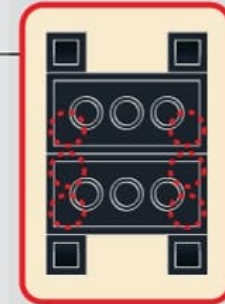
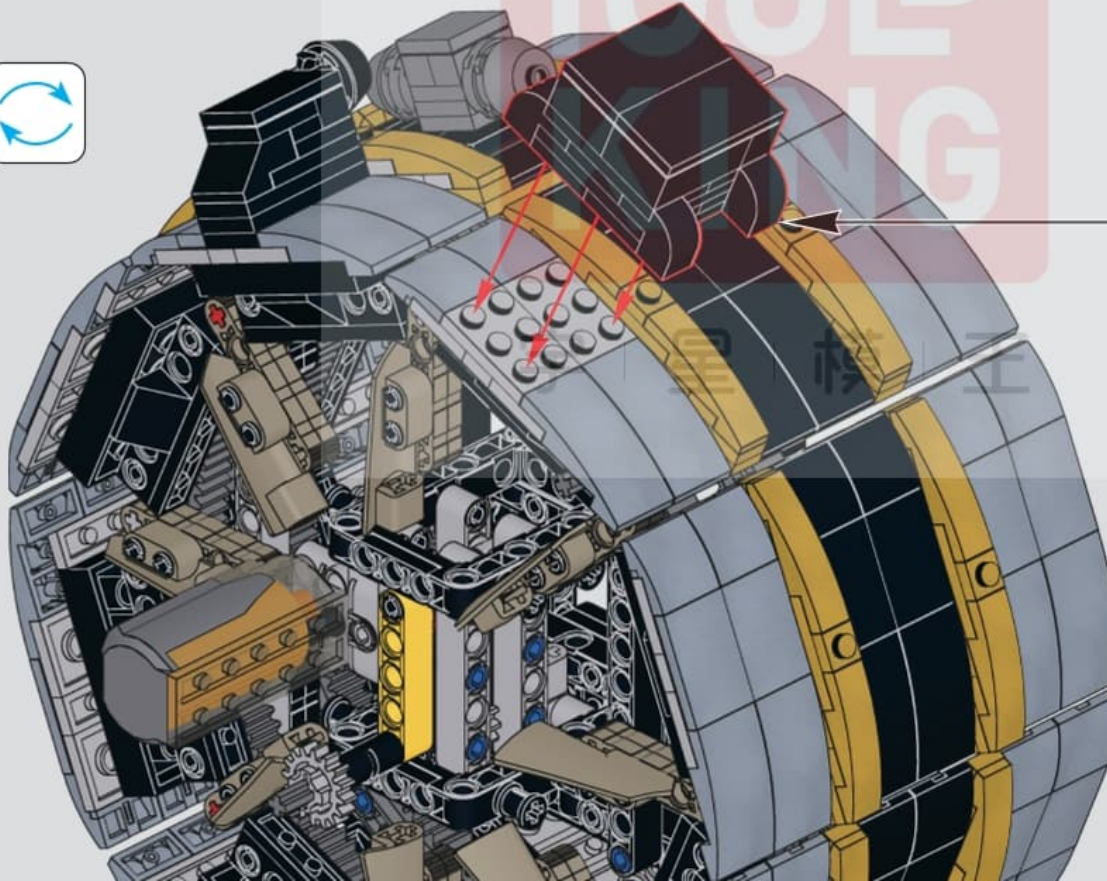



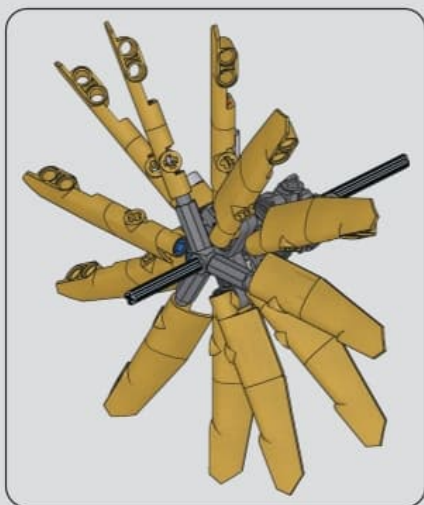

279

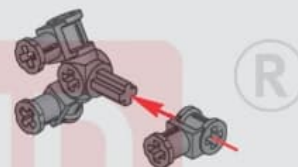

280



281

宇 | 星 | 模 | 王

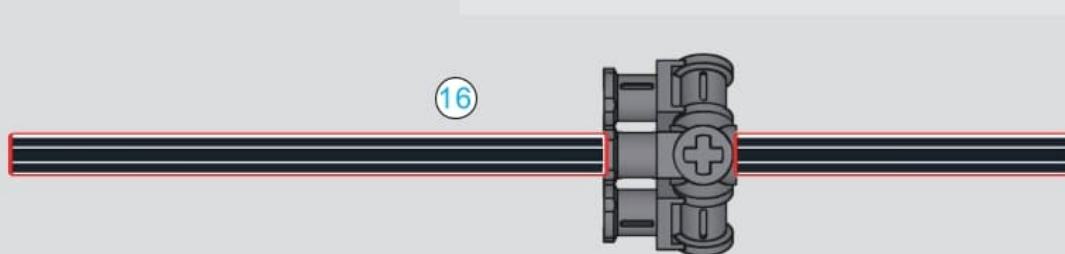

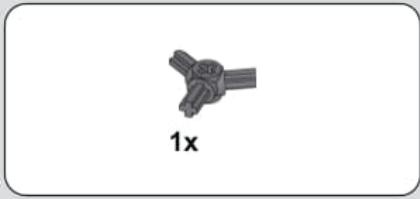

282

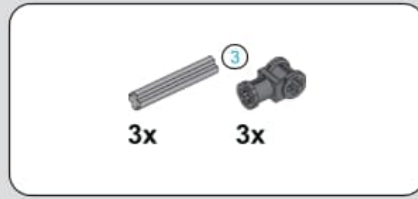

283

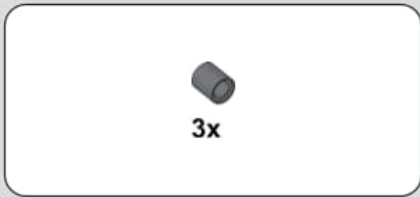
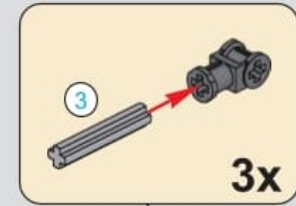
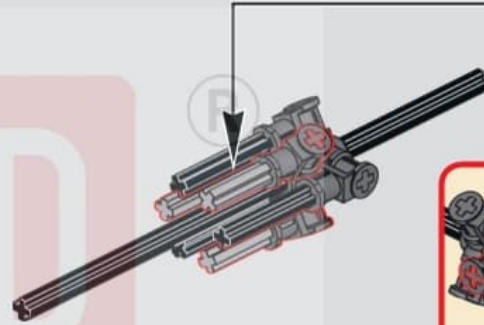

284

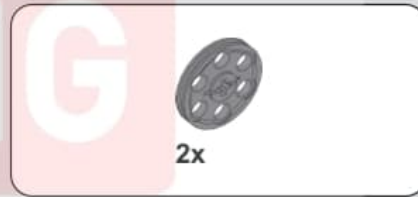
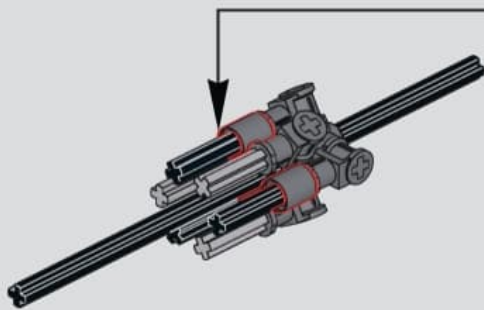

285

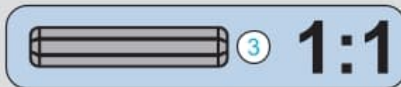
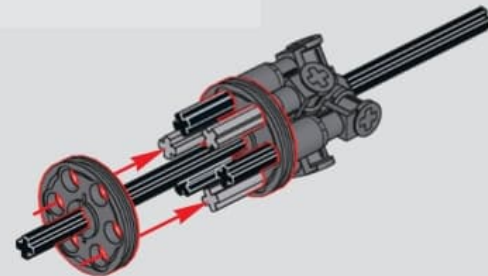

MULD  
KING

宇 | 星 | 模 | 王



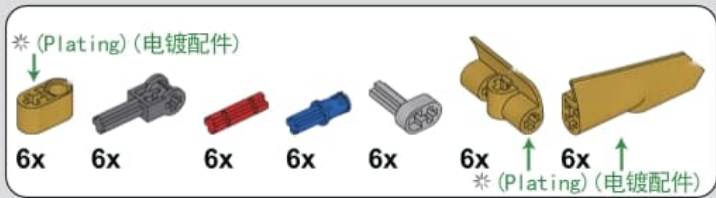

286

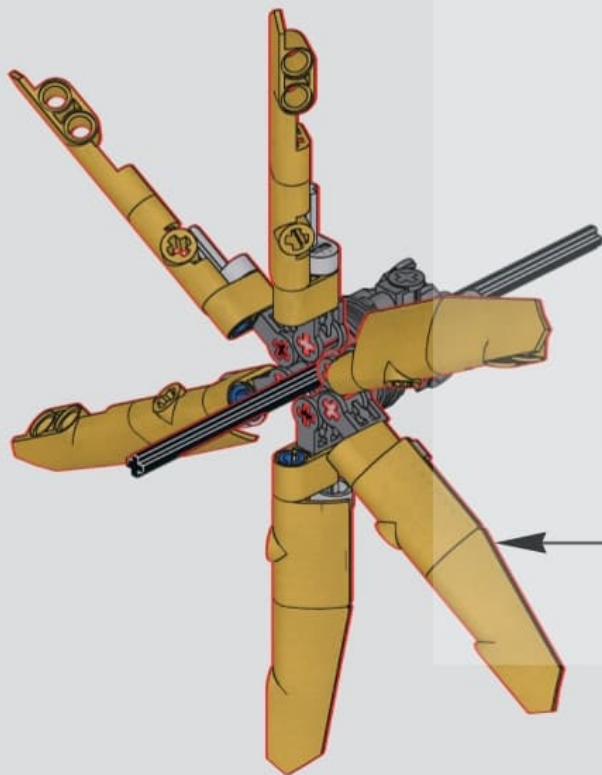

287

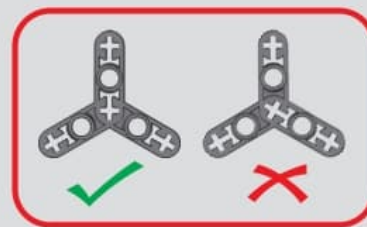
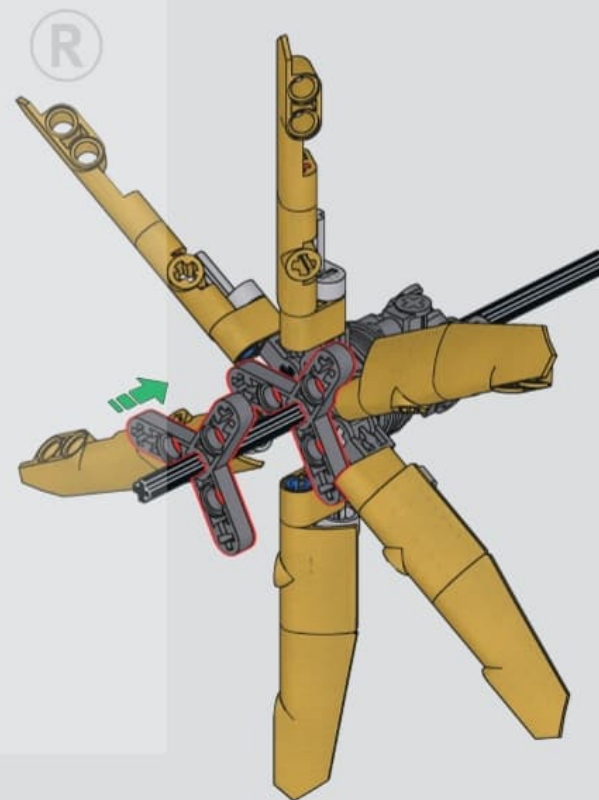



288

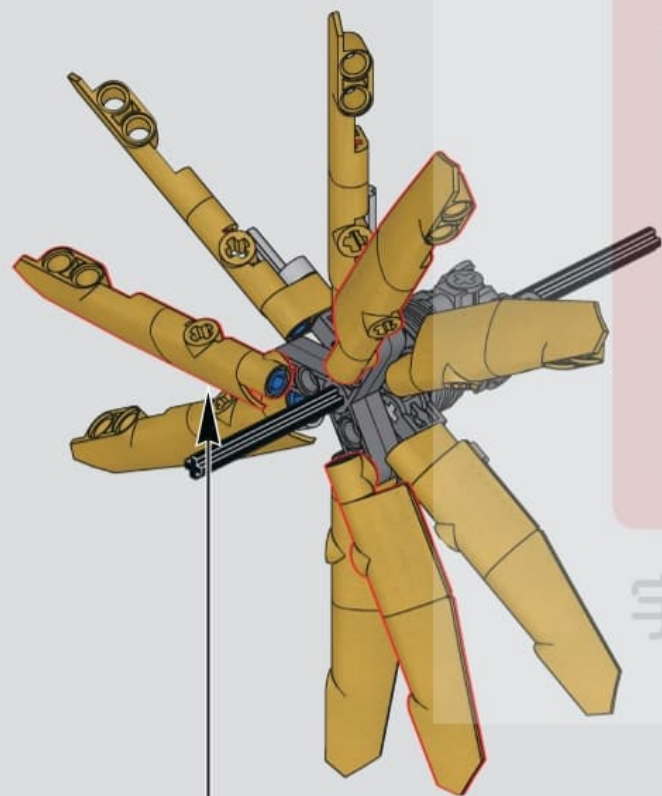

289

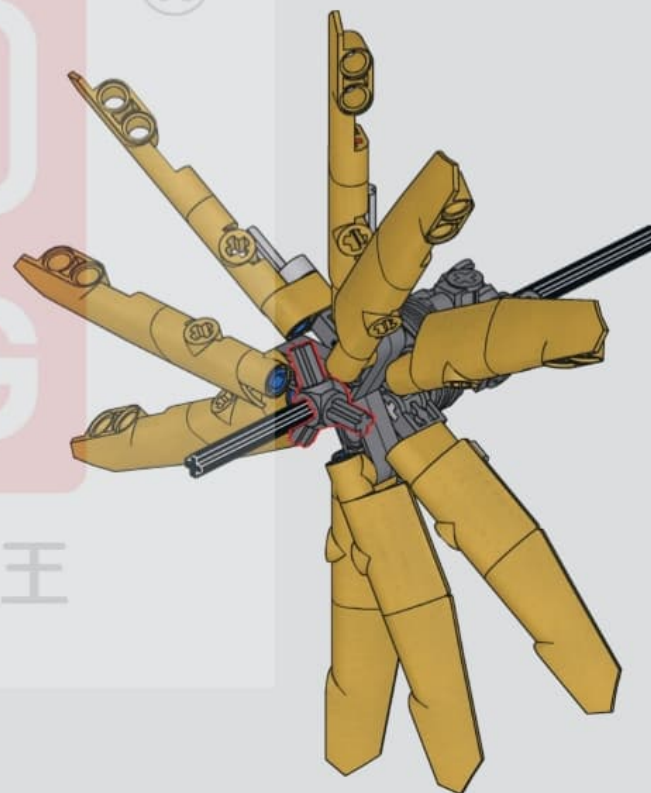



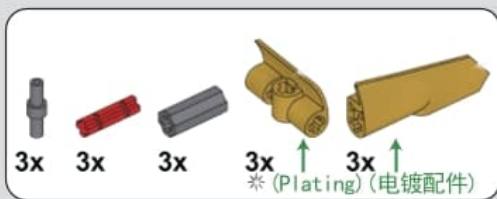

290

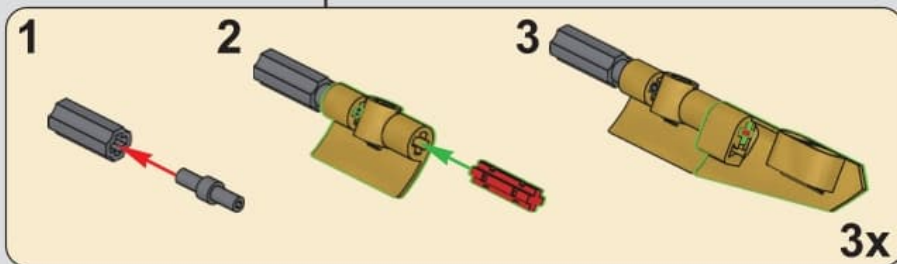
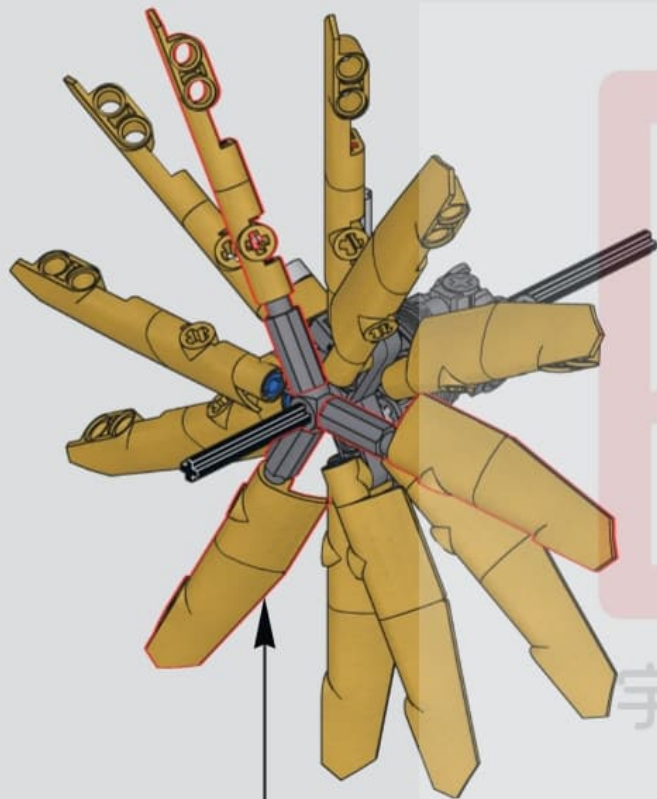

291

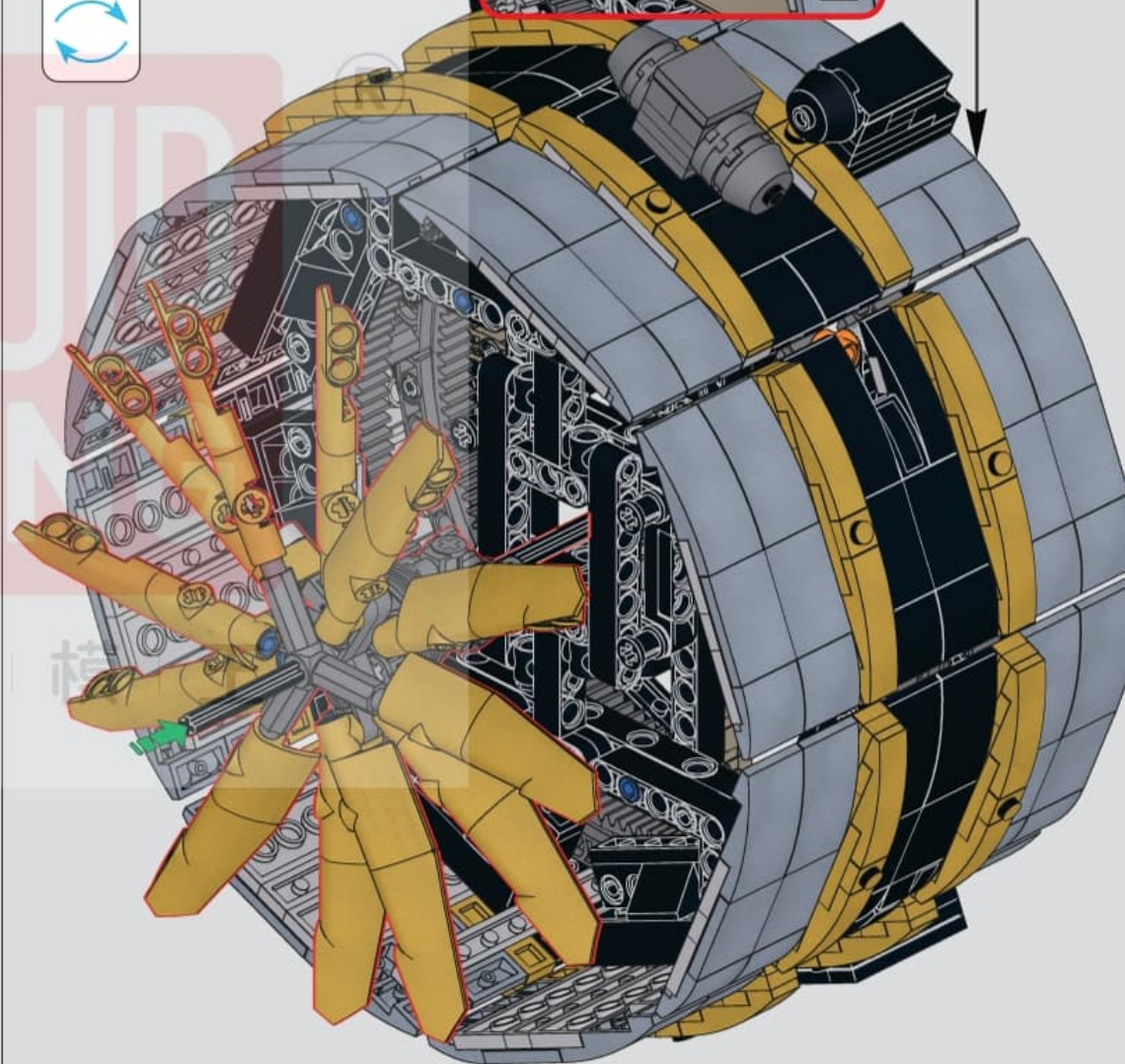
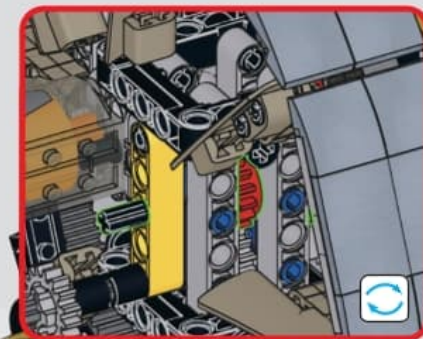



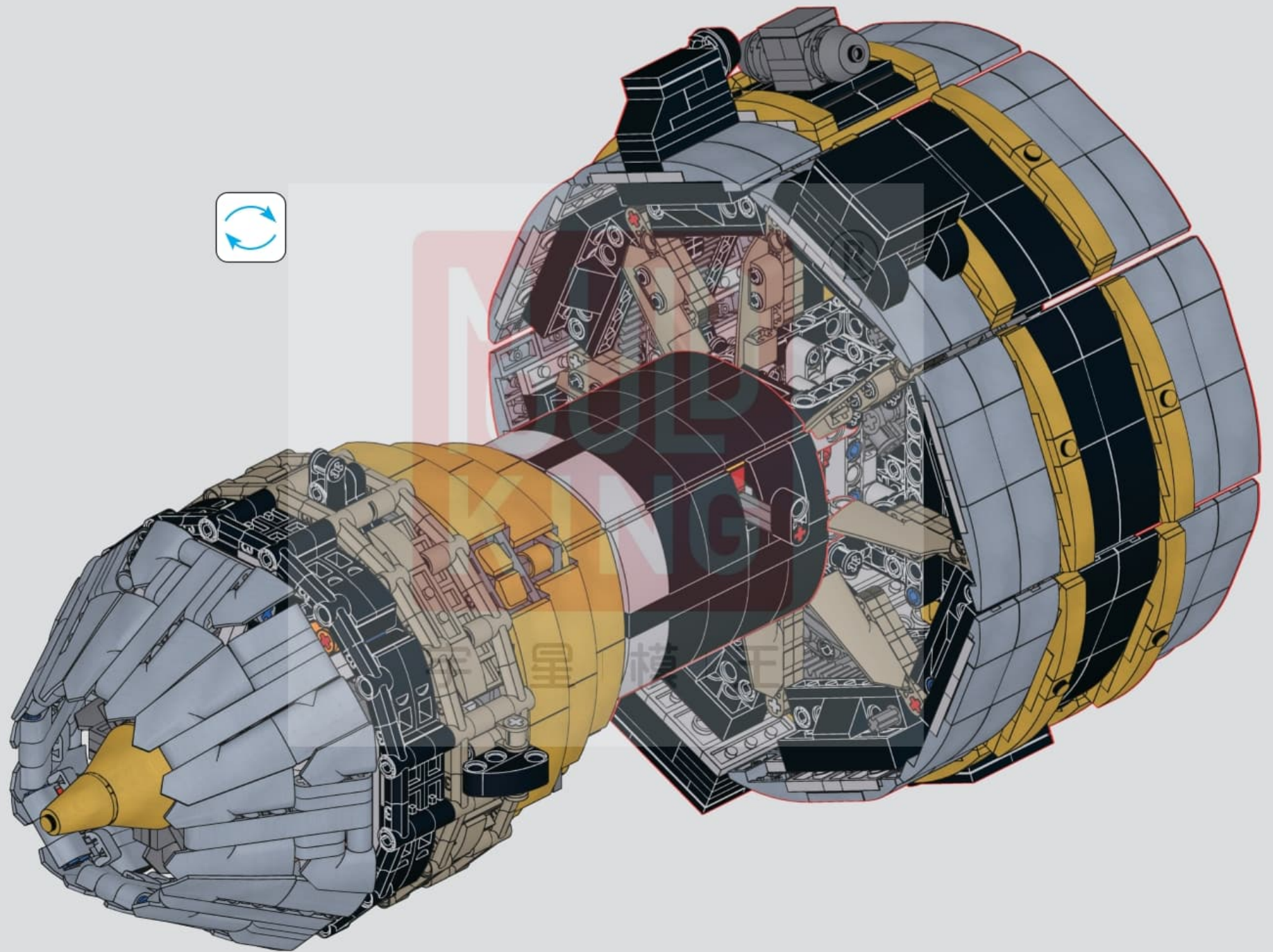





293

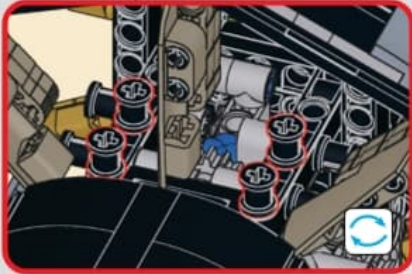
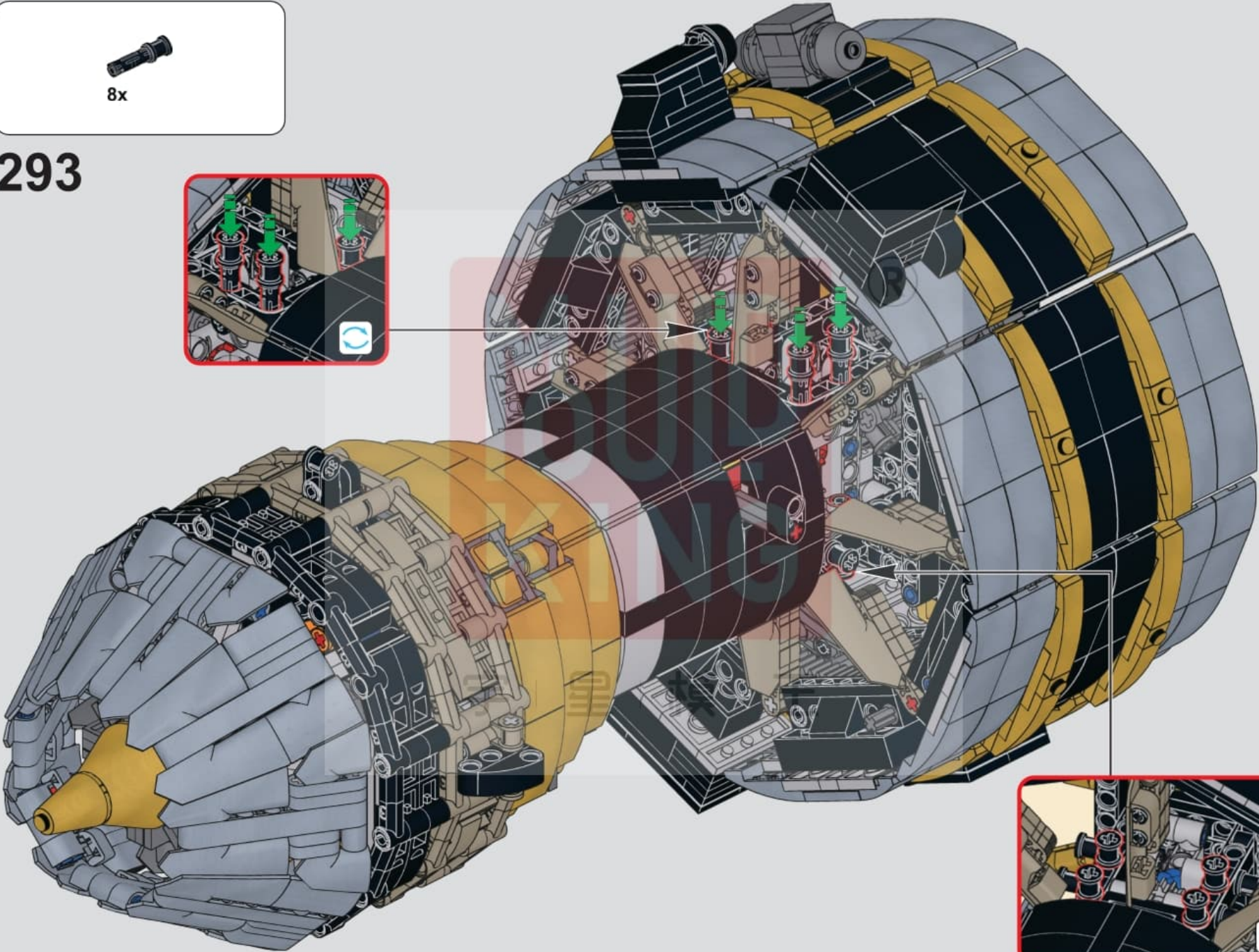
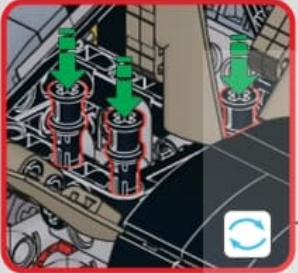



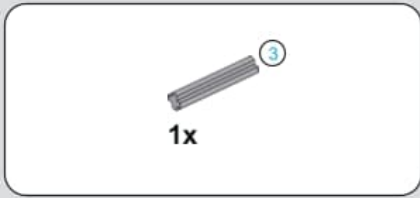

294

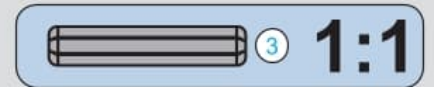
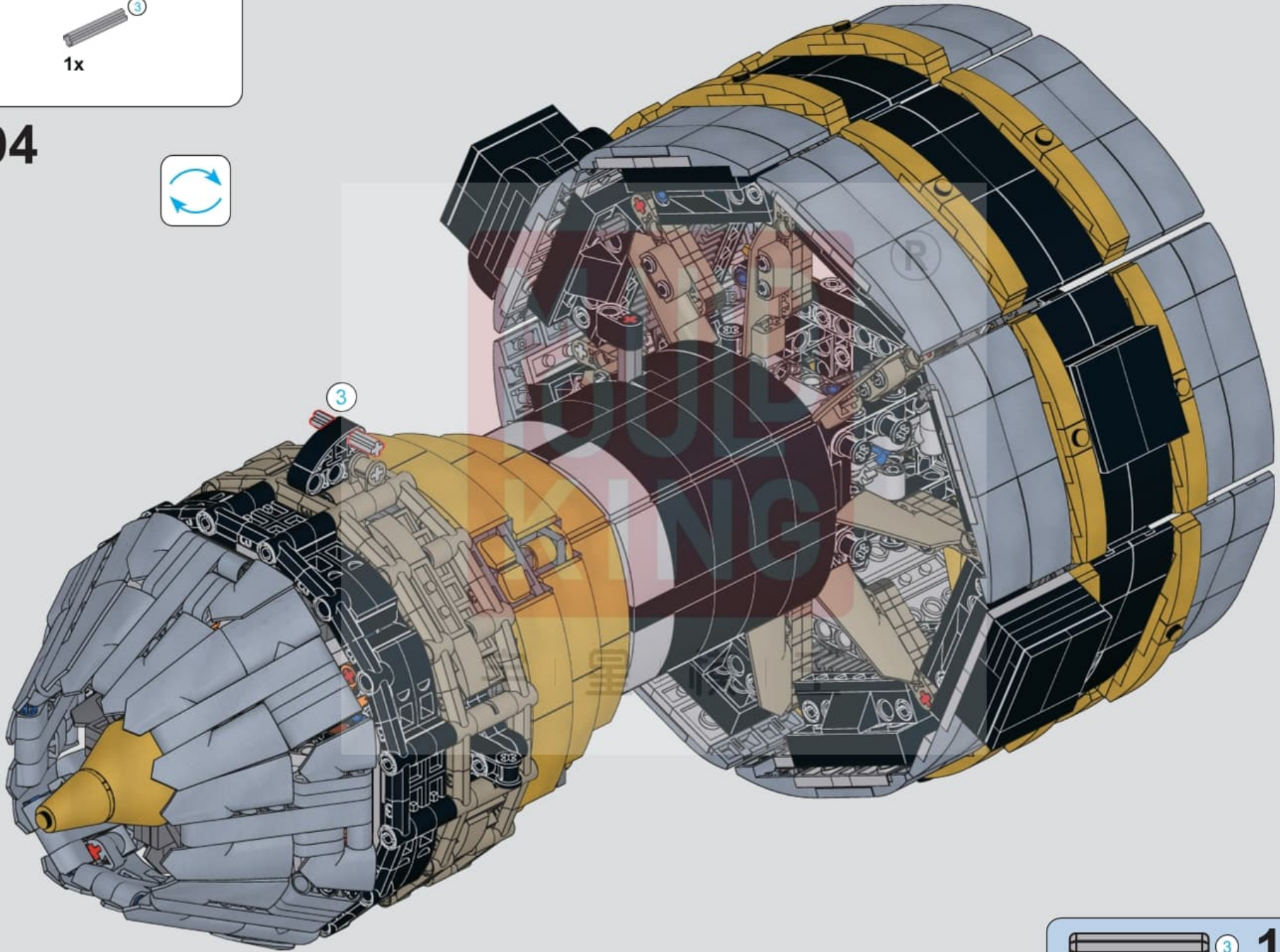





295

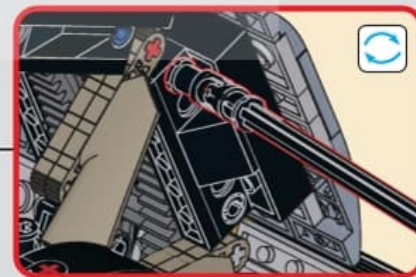
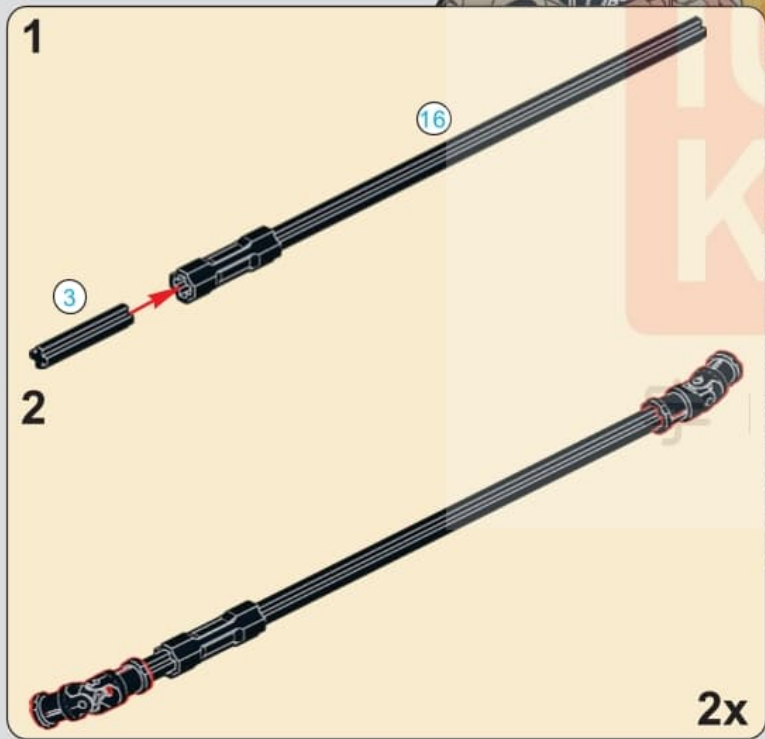





296

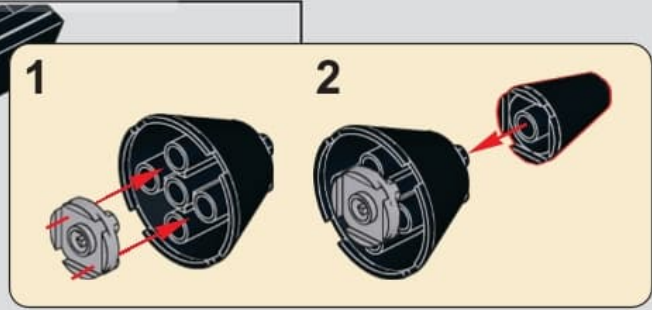
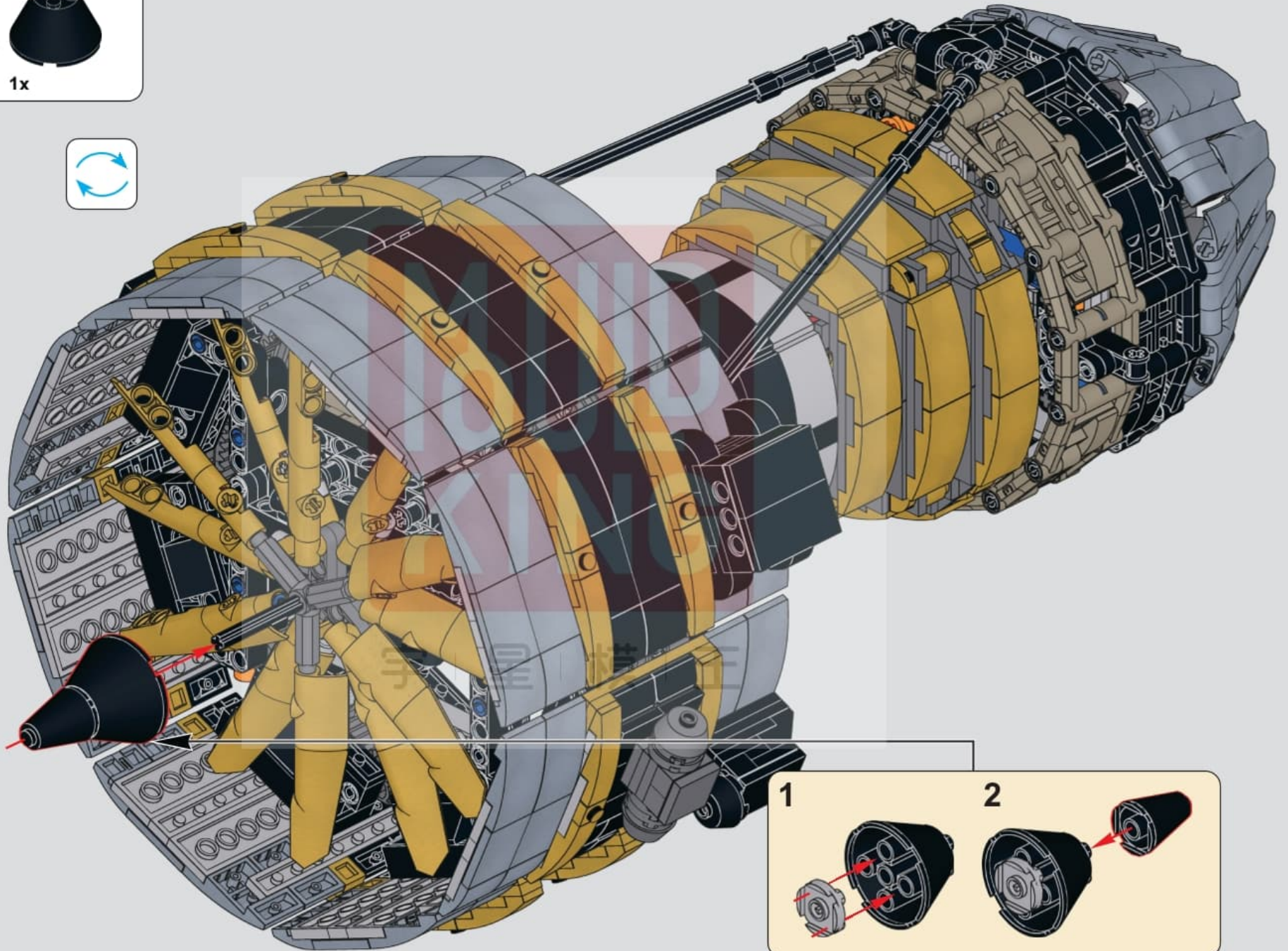



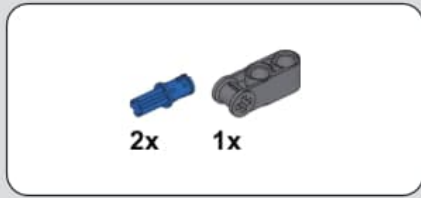
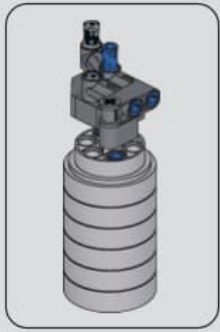

297

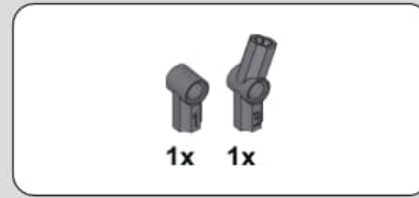

298

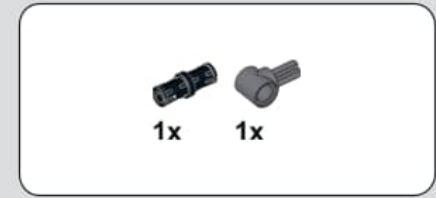

299

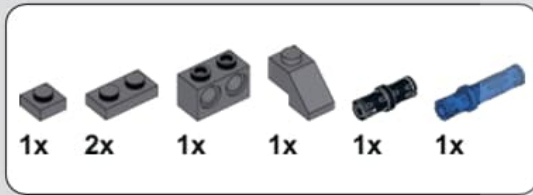
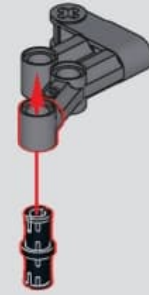
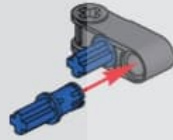
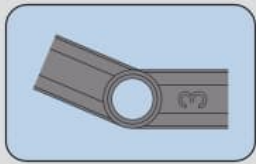

300



301

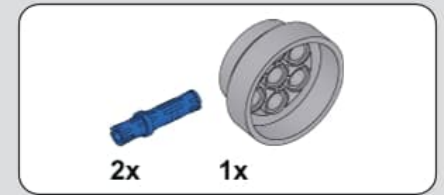

302

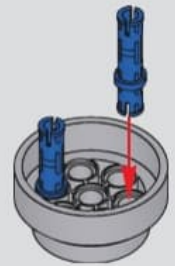
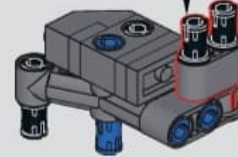
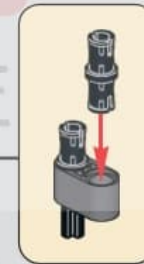
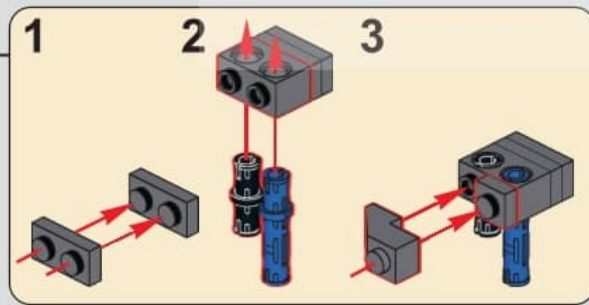
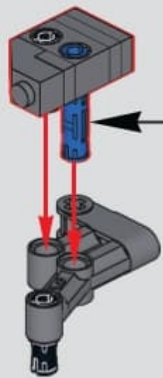

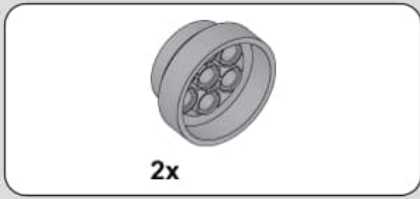

303

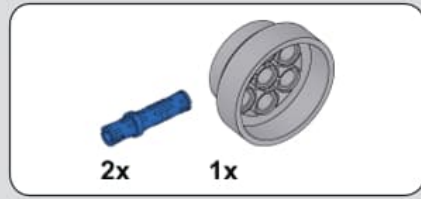
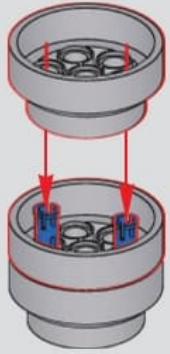

304

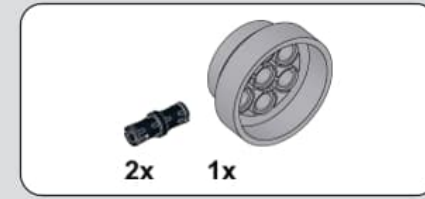
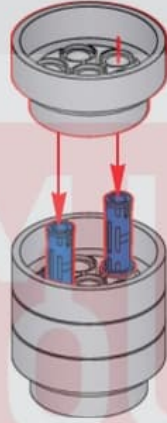

305

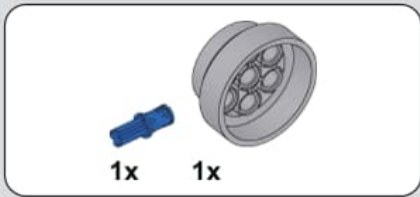

306



307



308

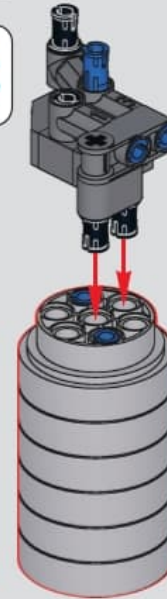



309

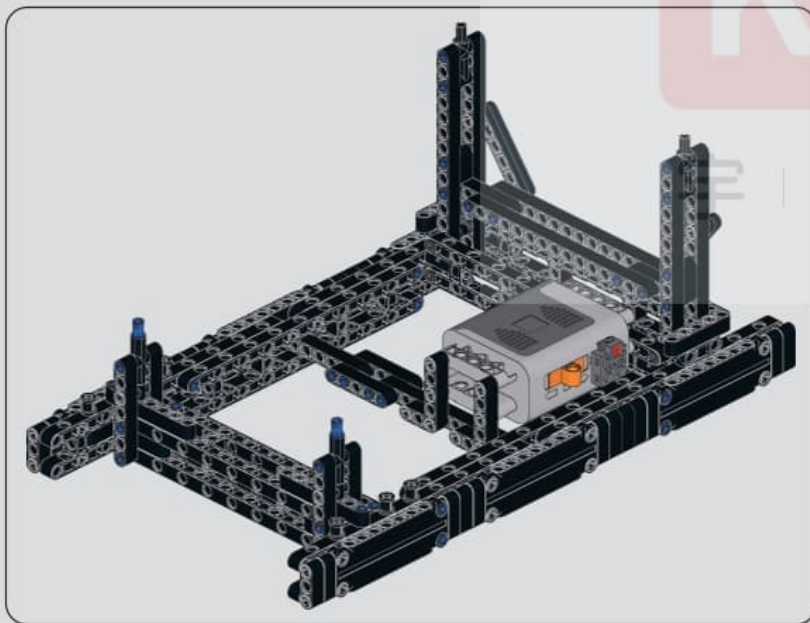
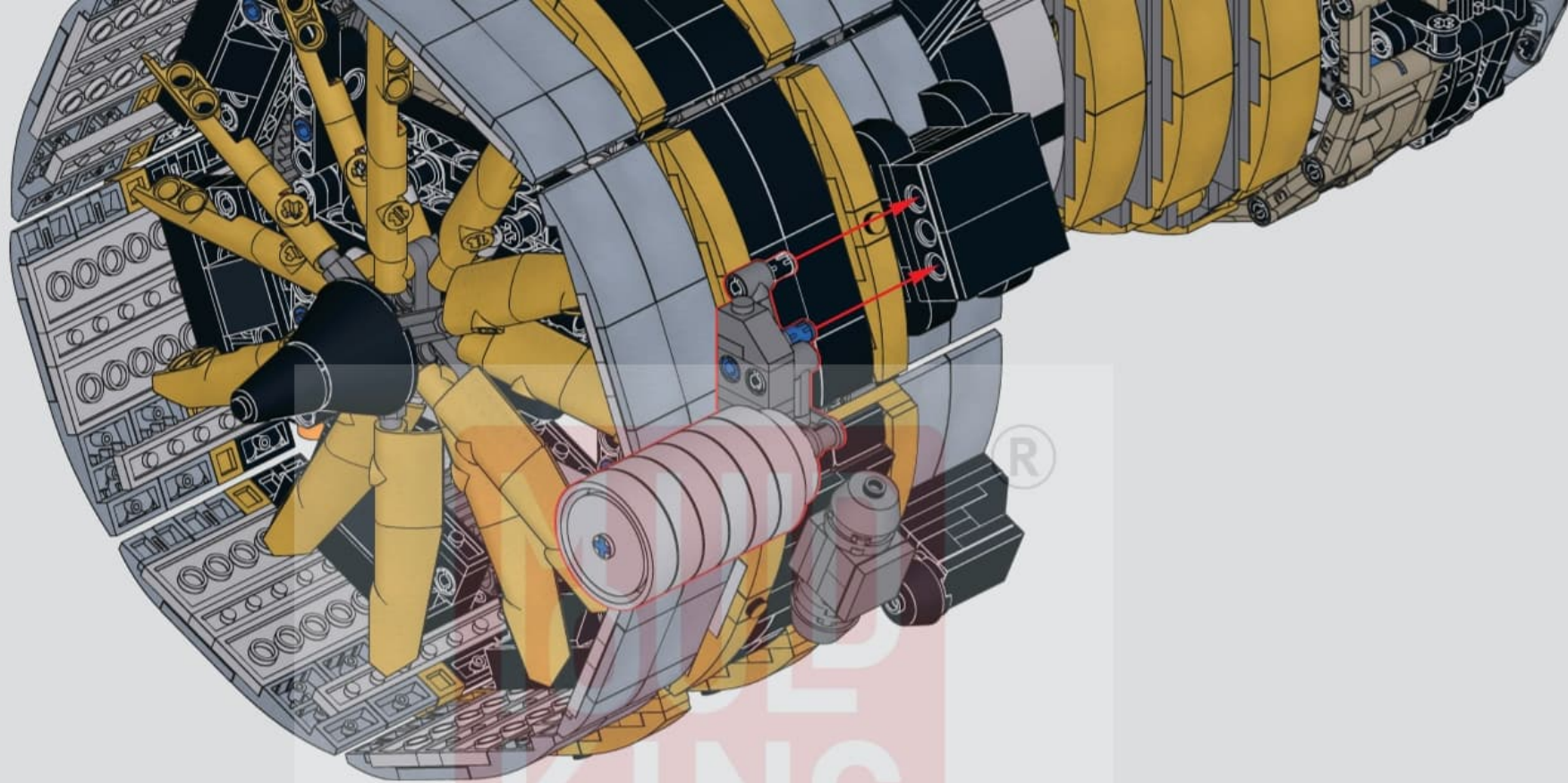

310

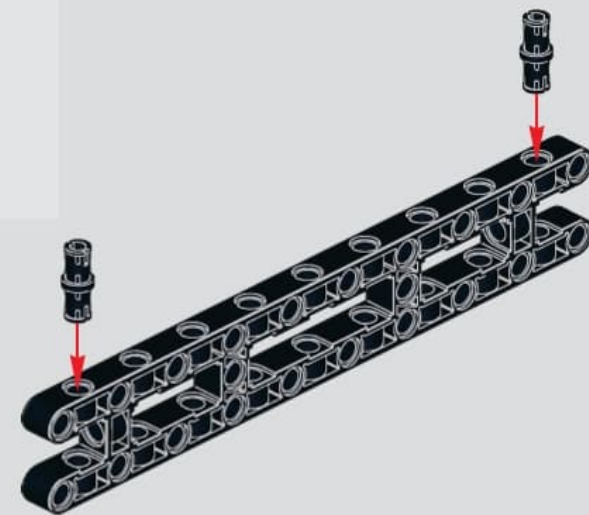



311

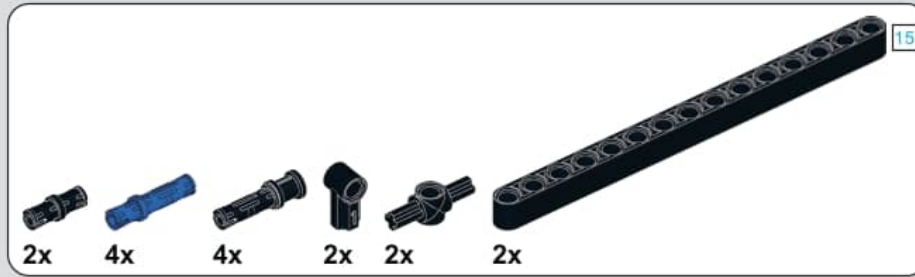
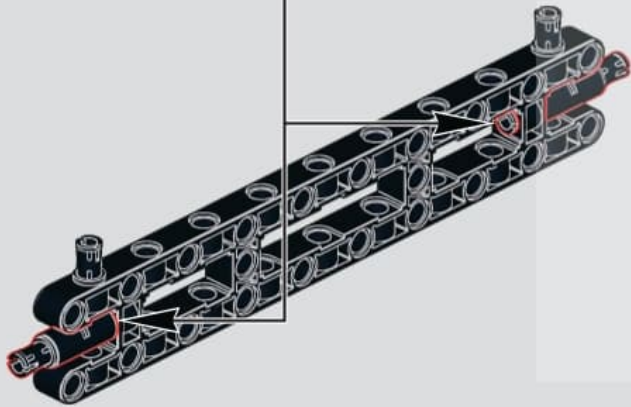
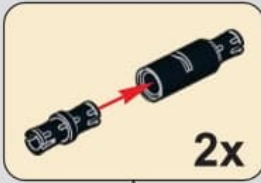

312

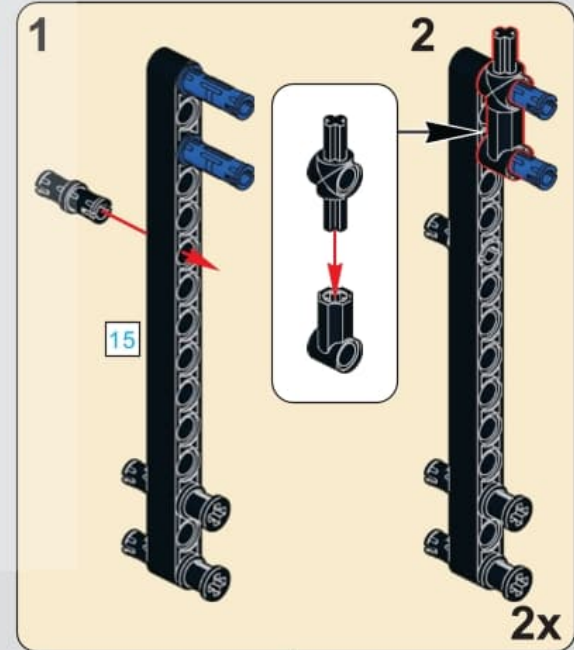
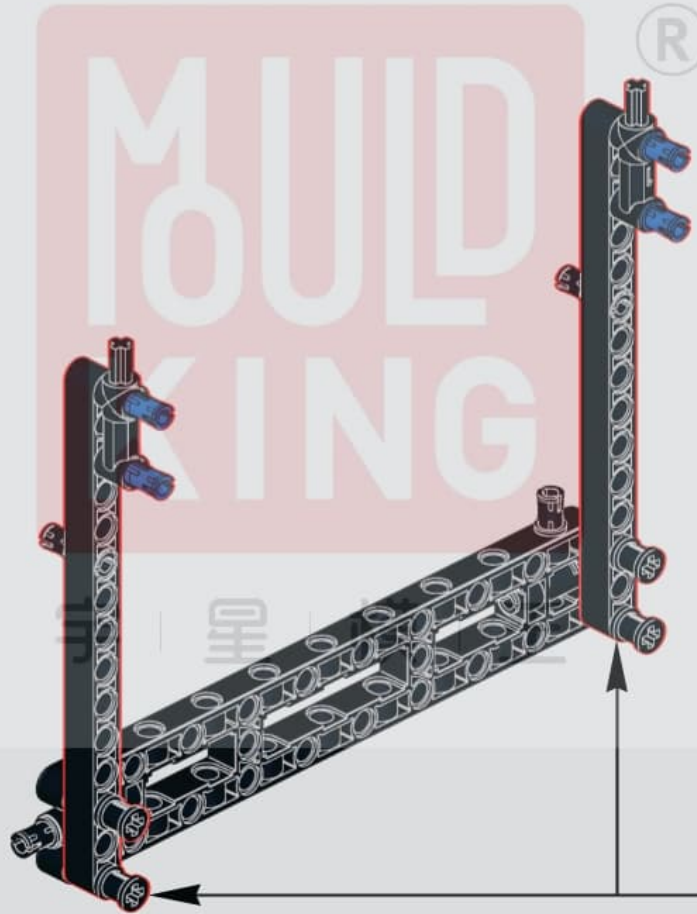



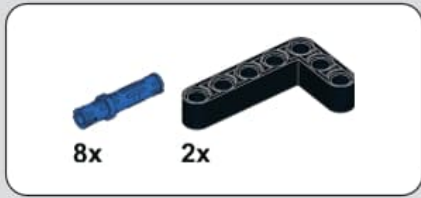

313

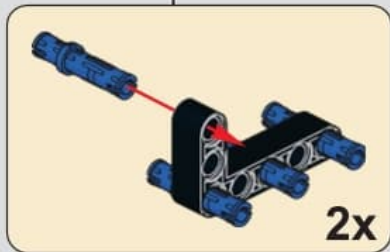
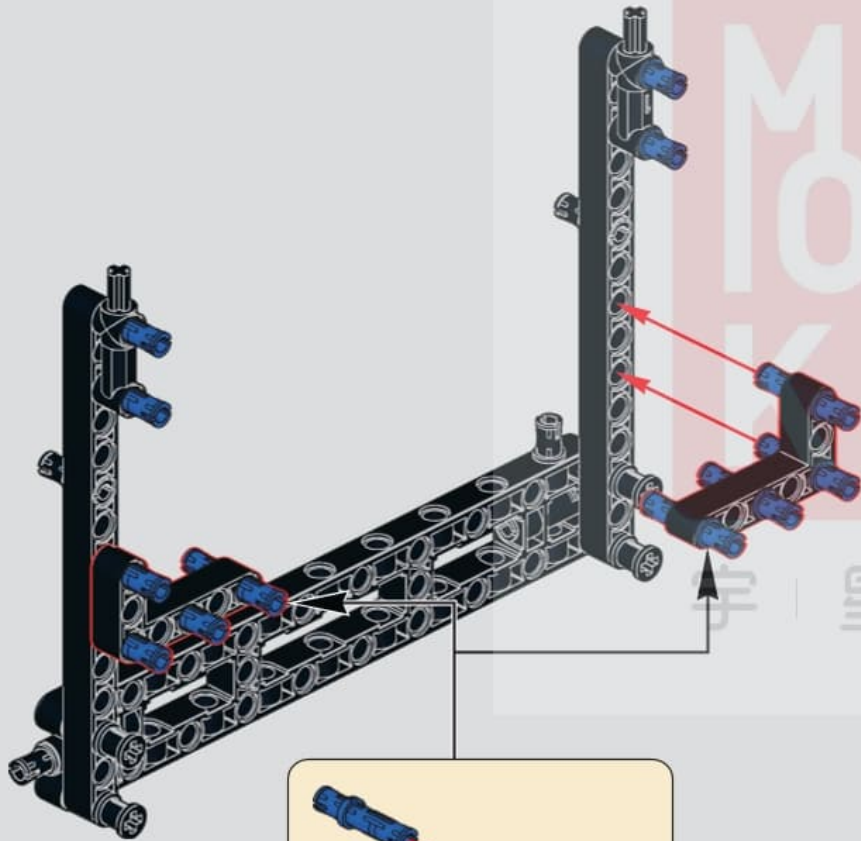

314

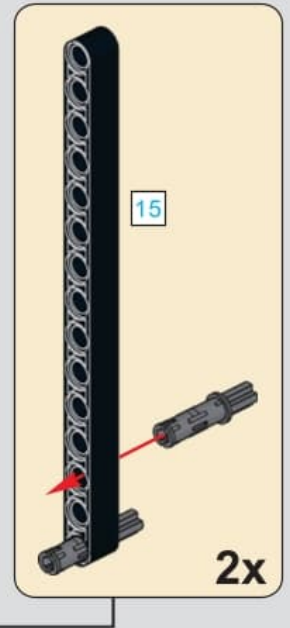

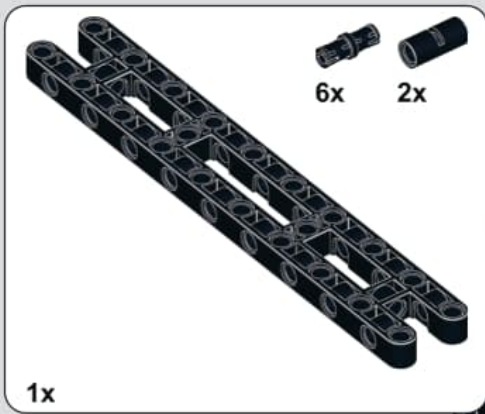

1x

315

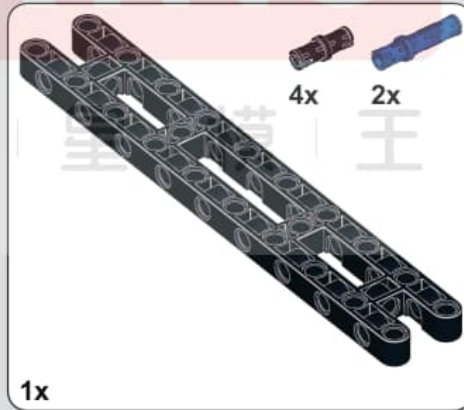
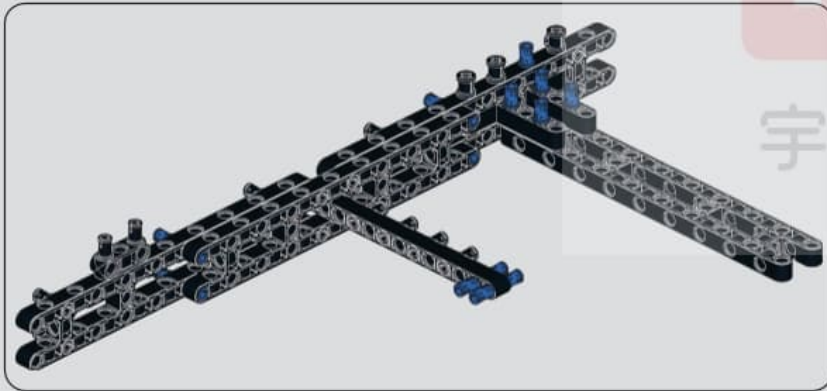
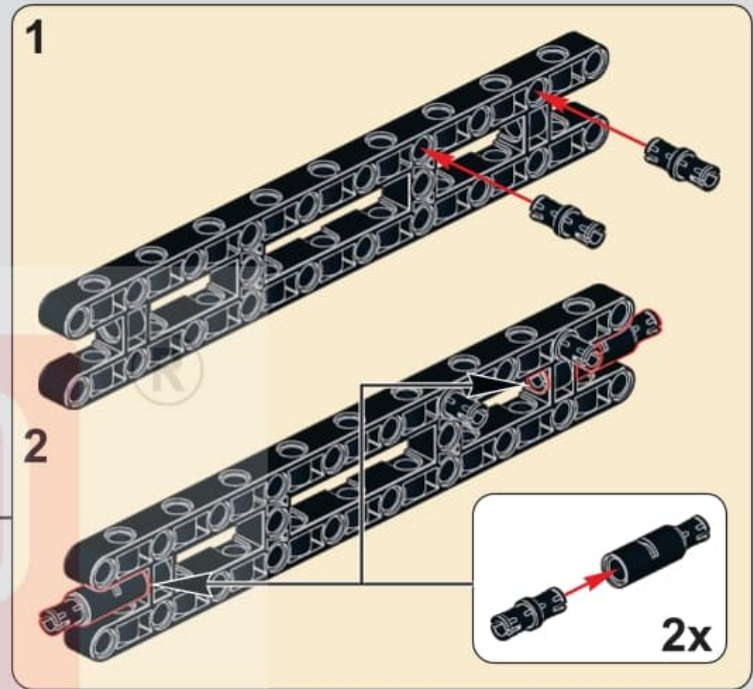

1x

316

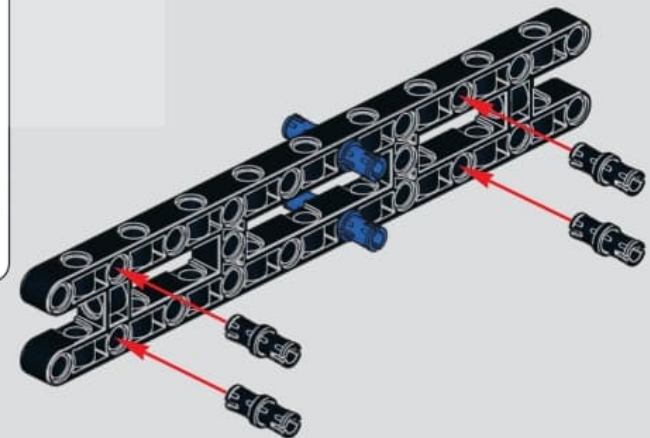





317

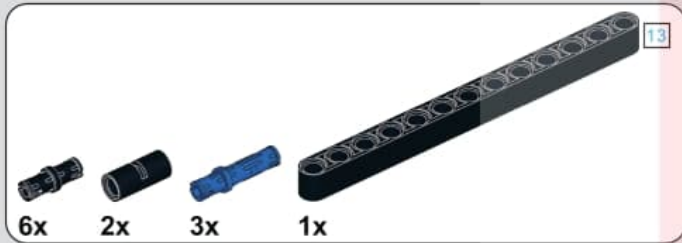
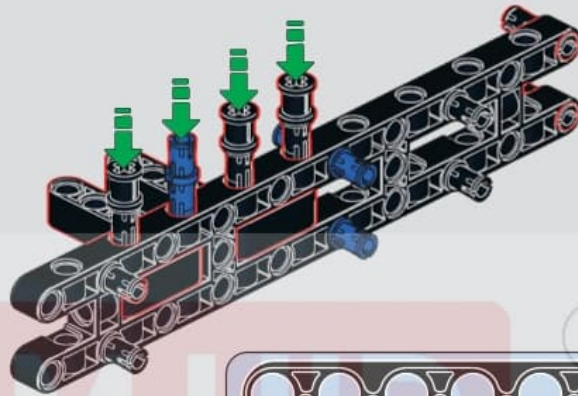

318

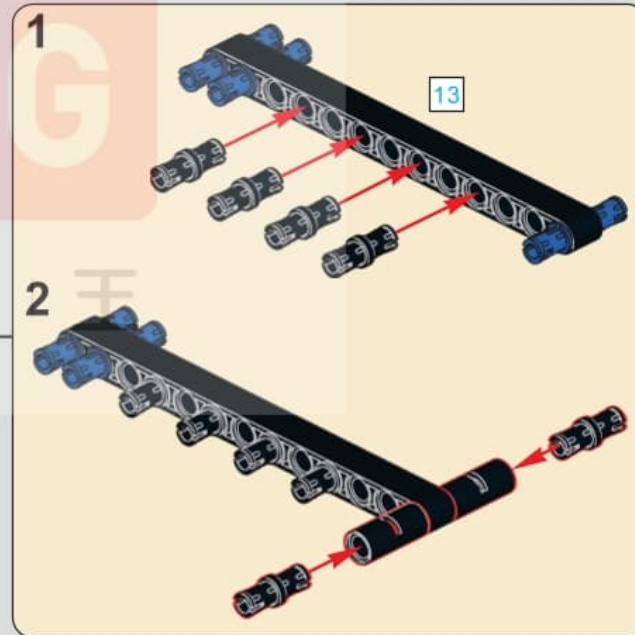
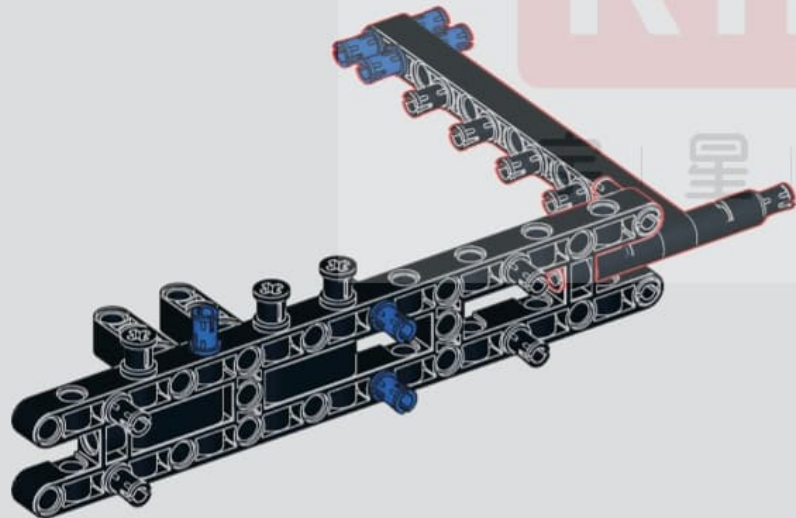

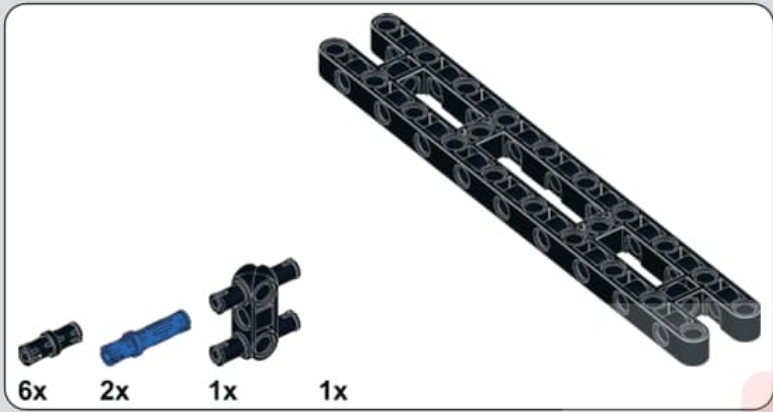

319

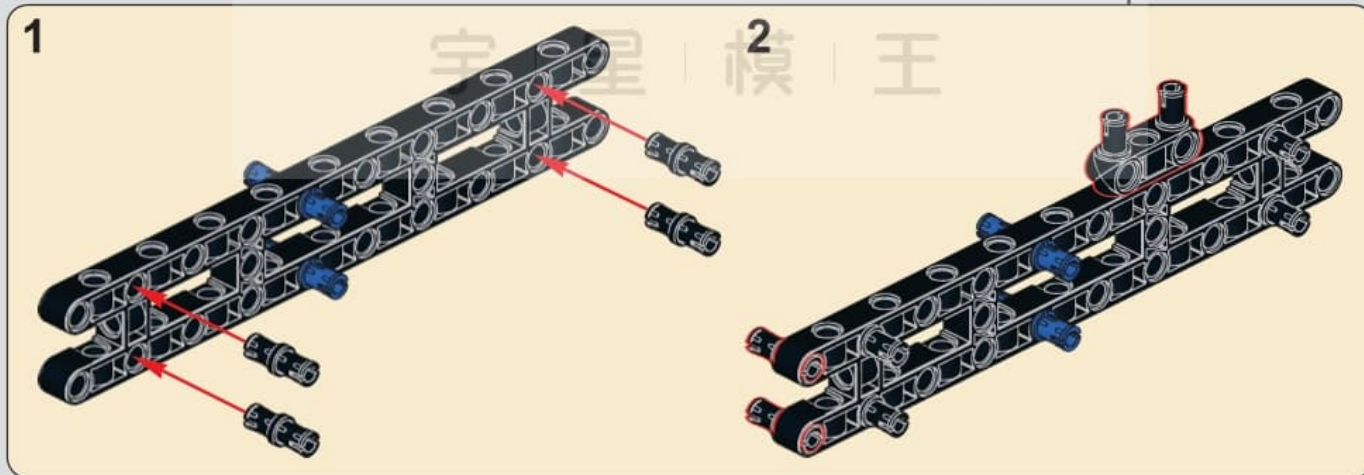
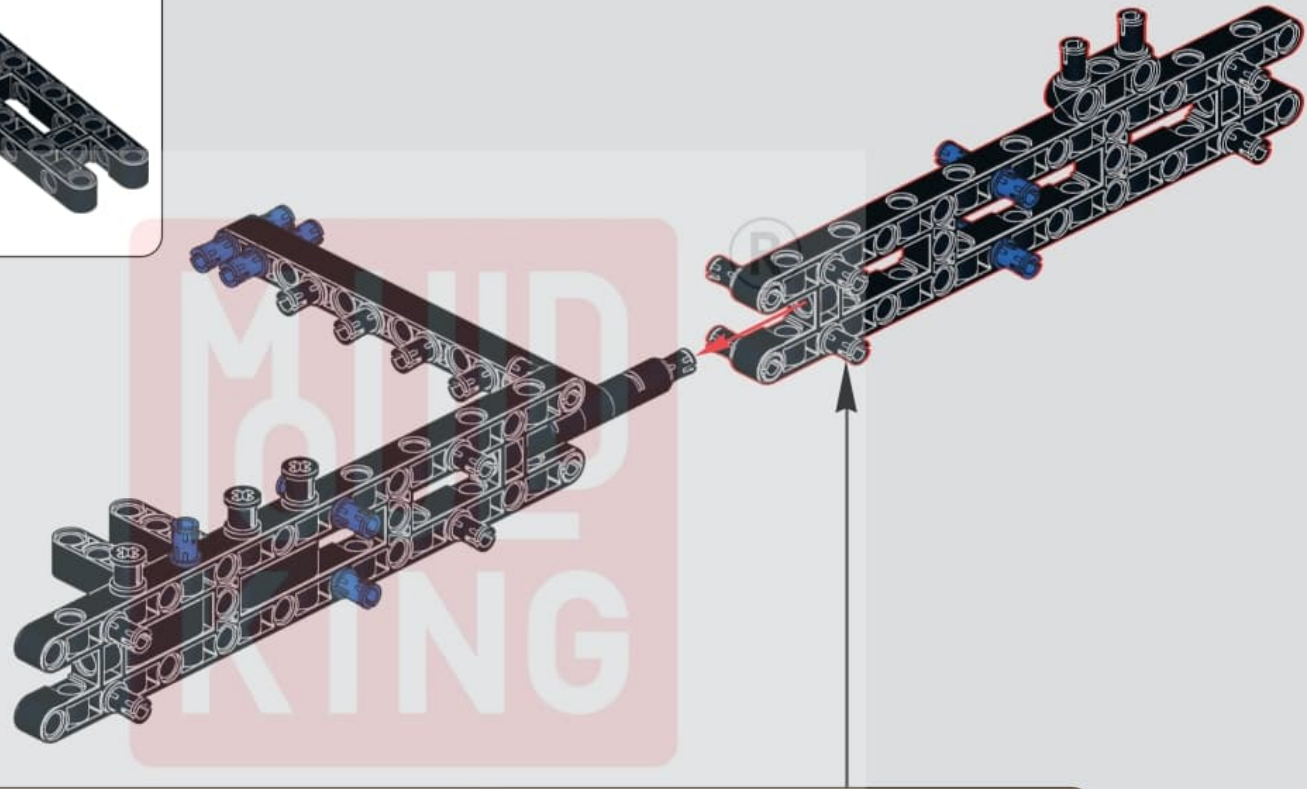





320

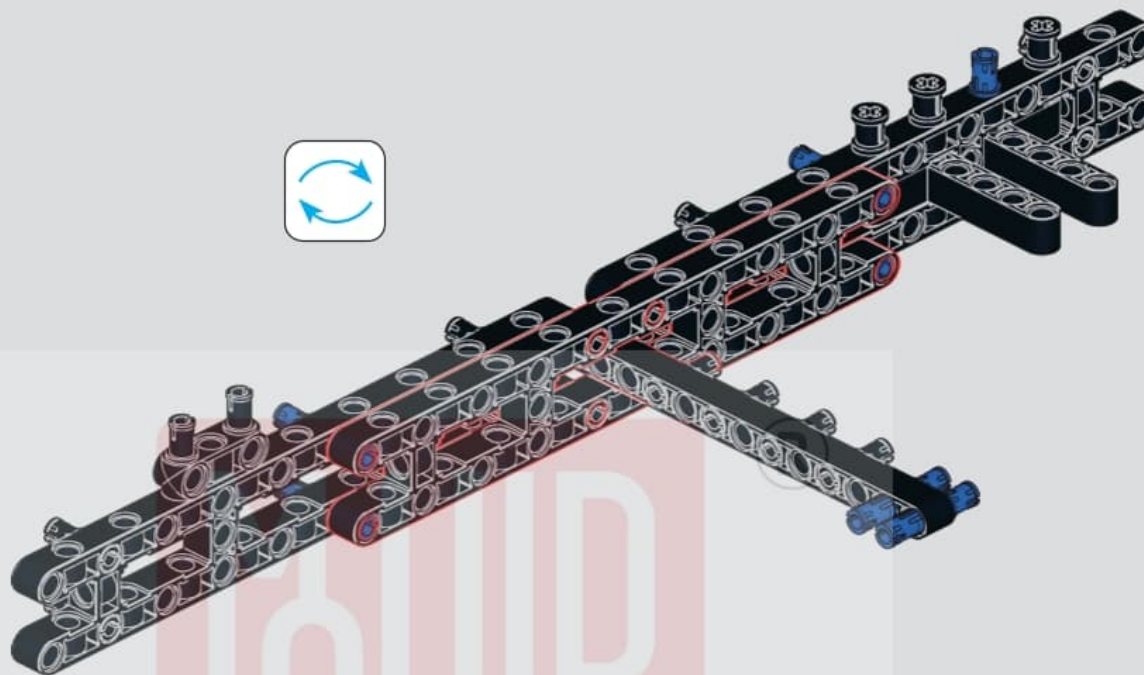

321

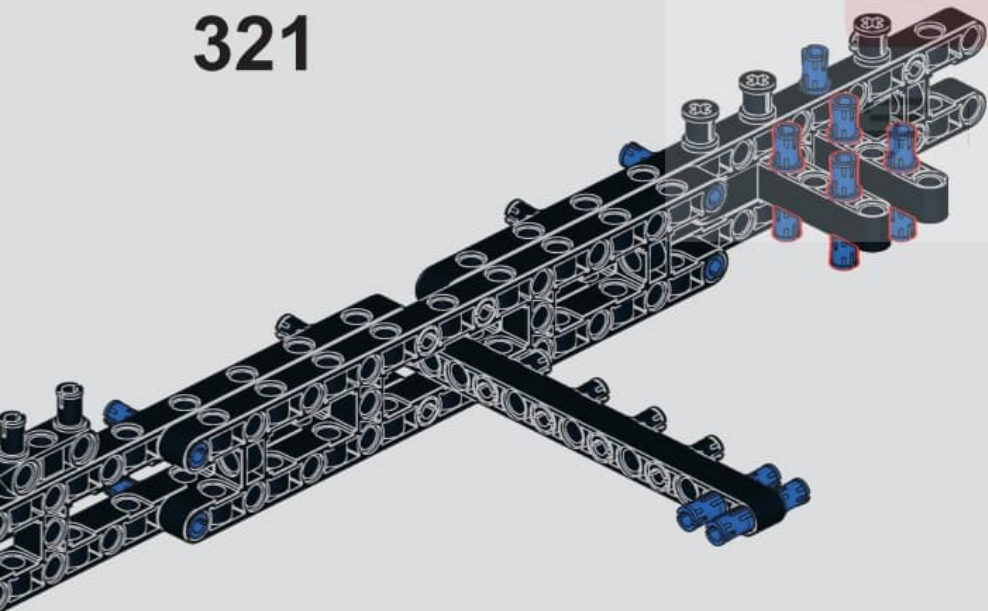

322

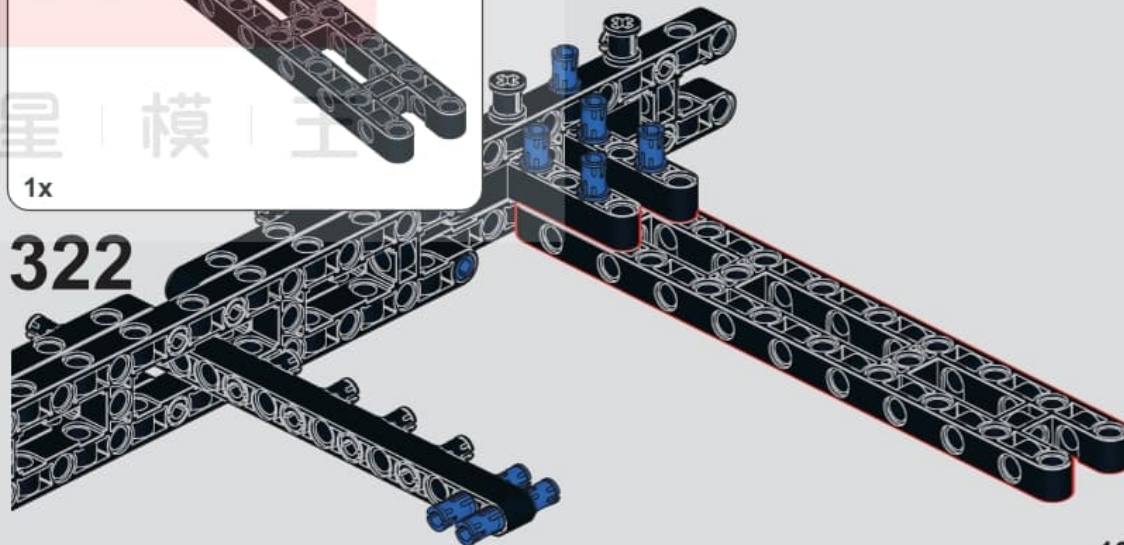

323

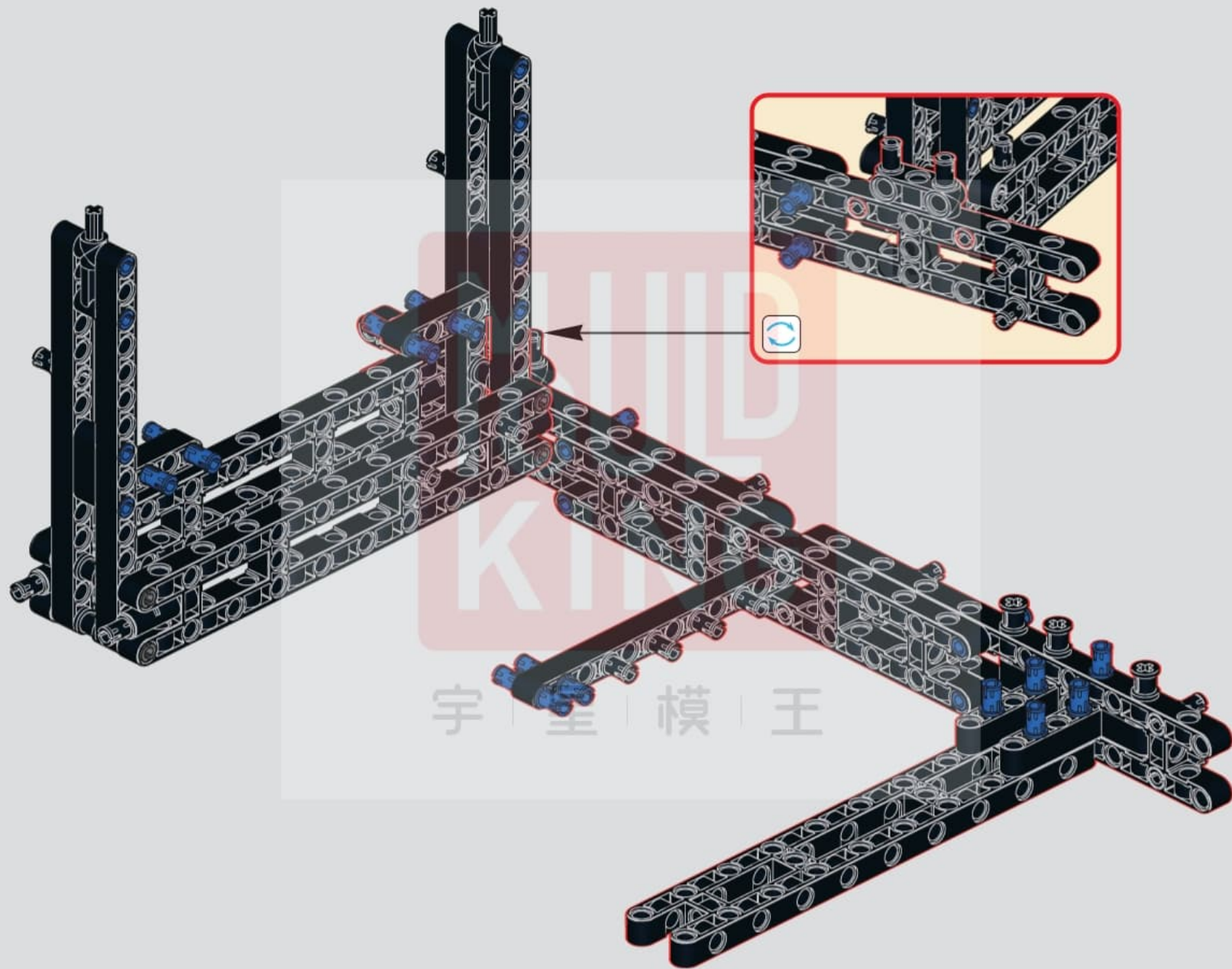



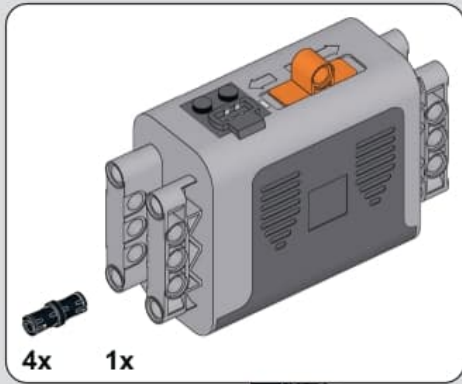

324

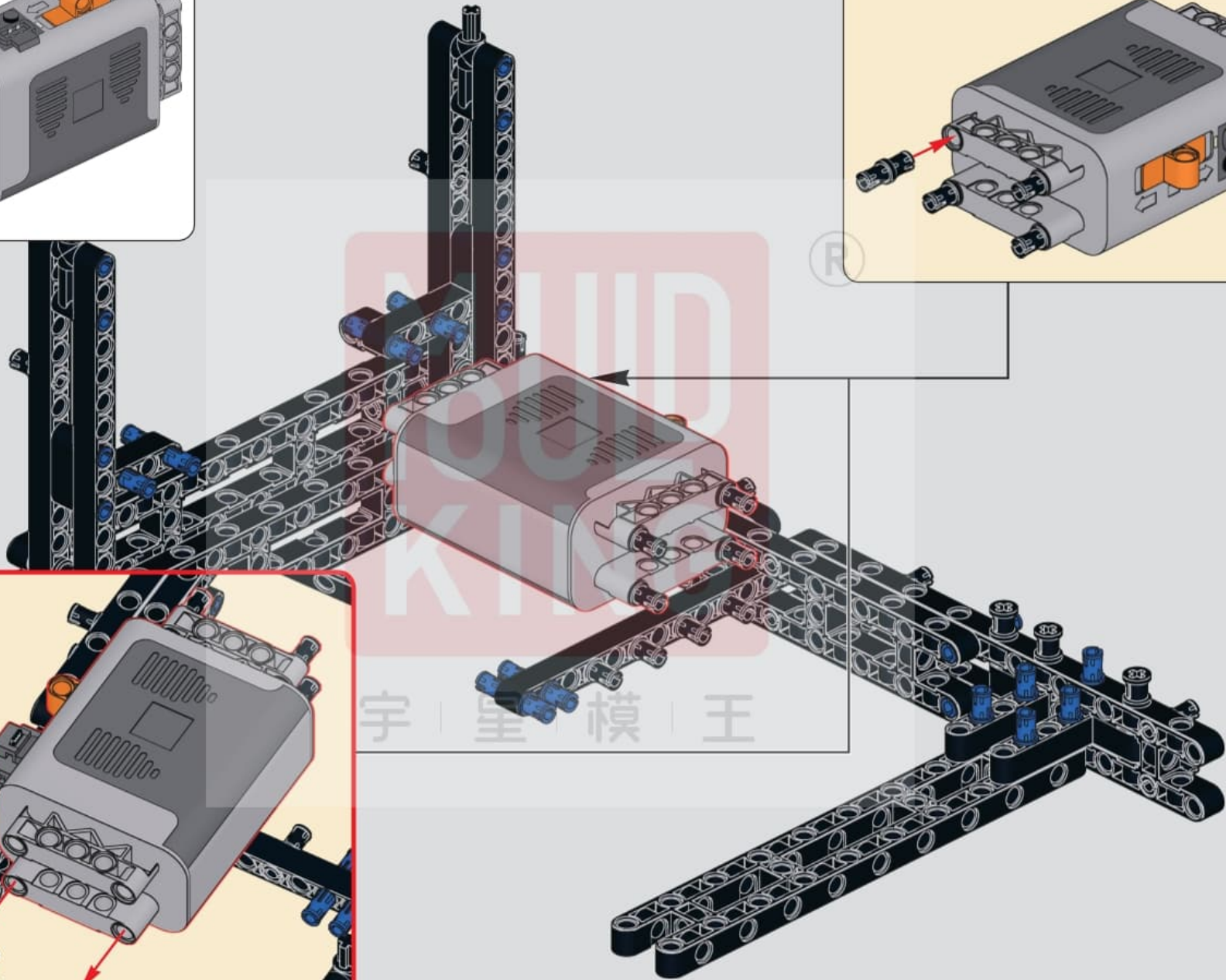
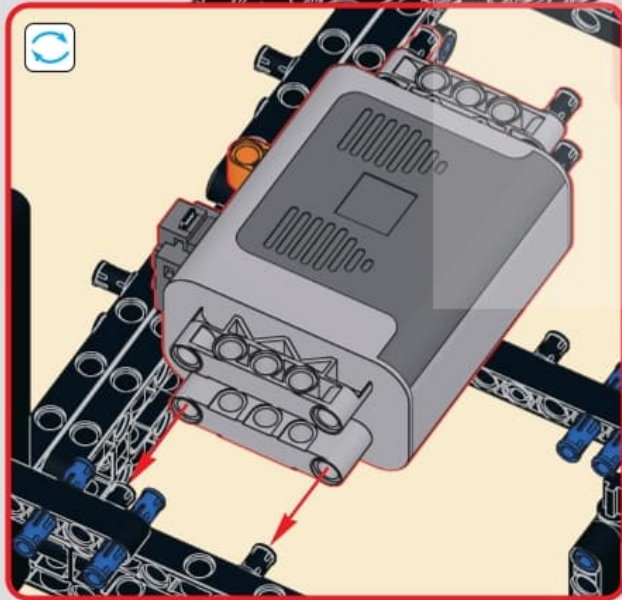
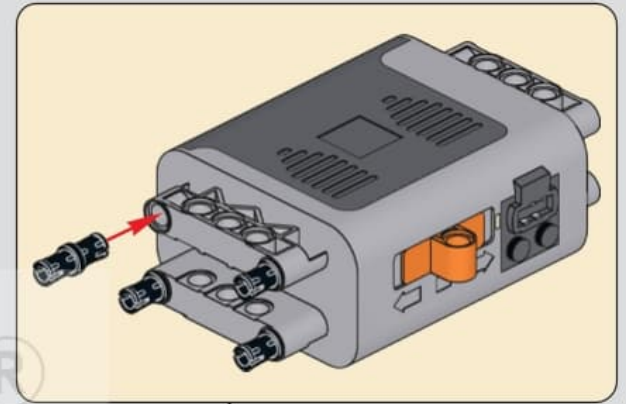



325

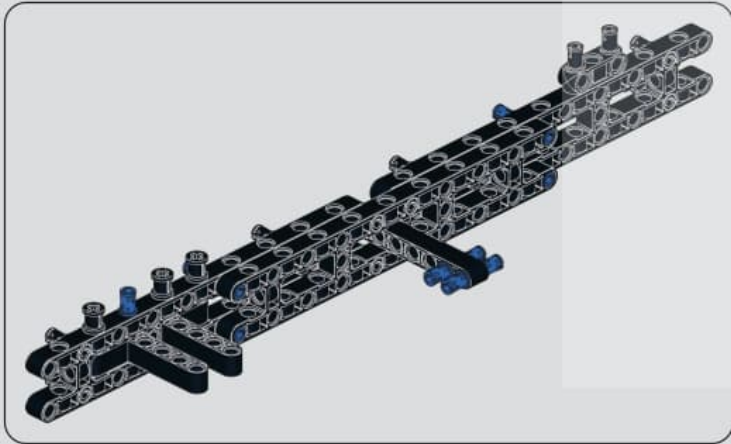
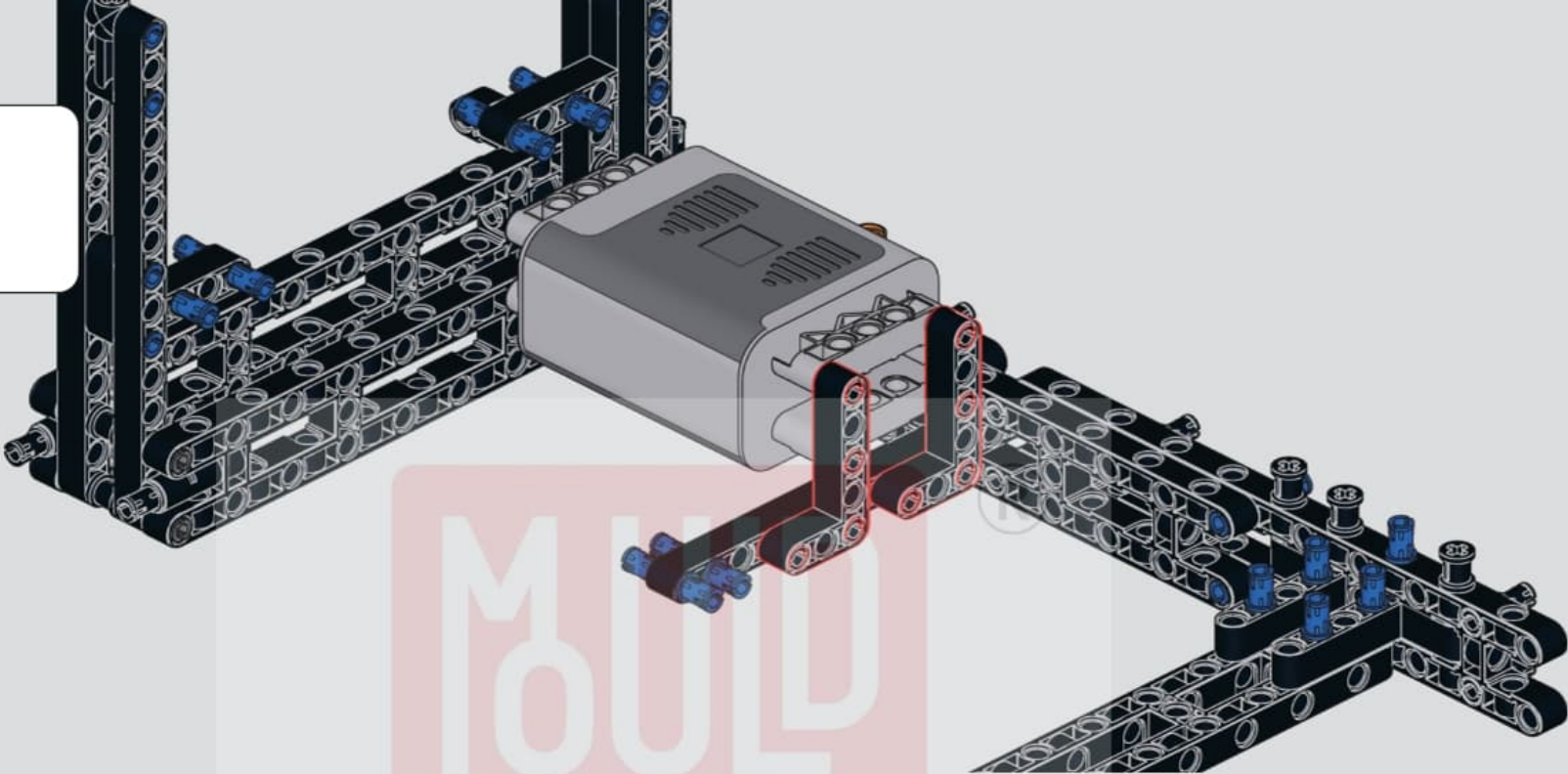

326

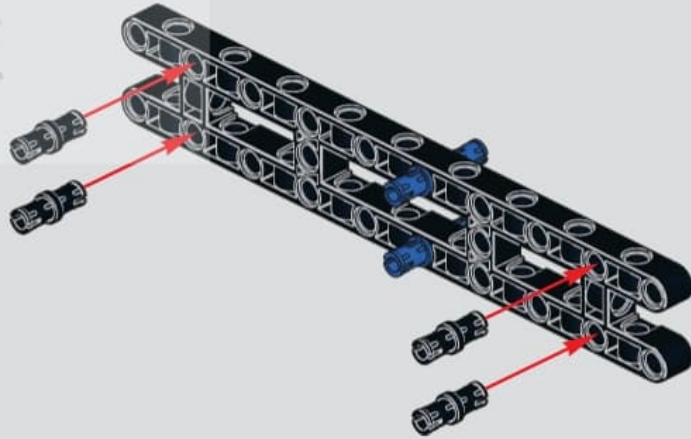





327

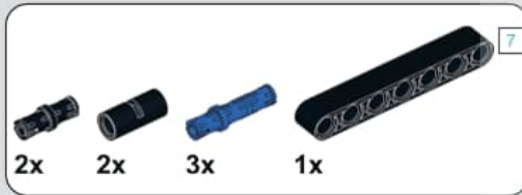
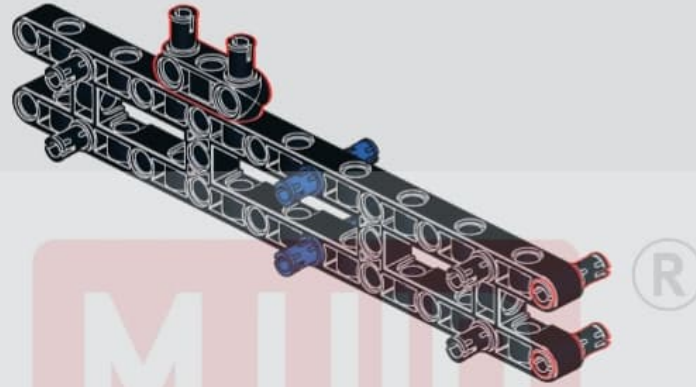

328

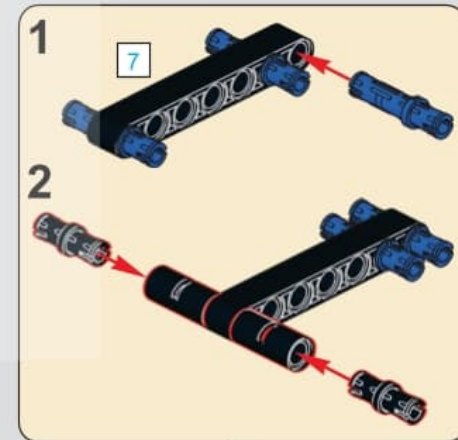
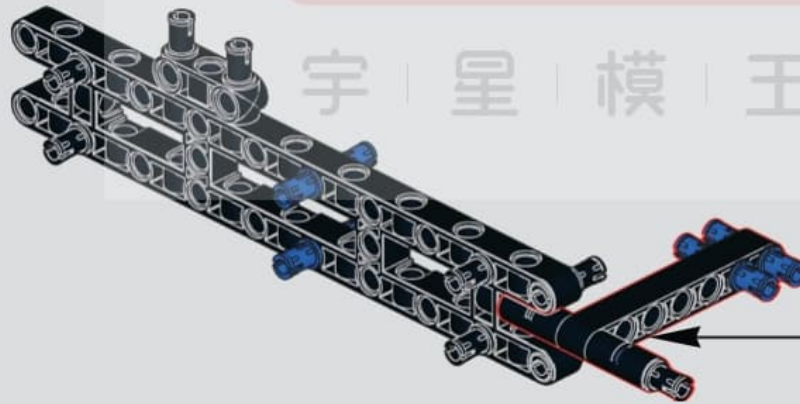

MULD  
KING  
宇 | 星 | 模 | 王

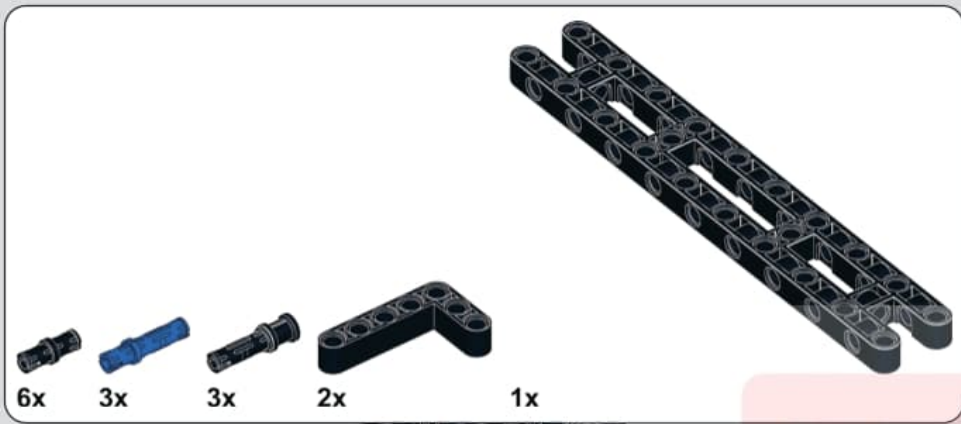

329

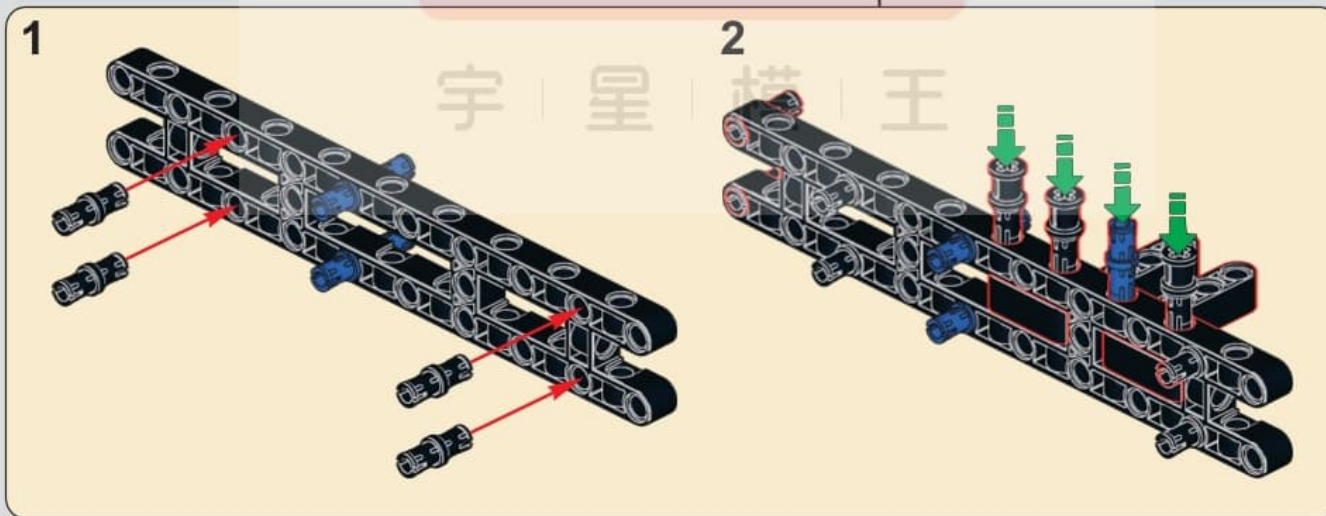
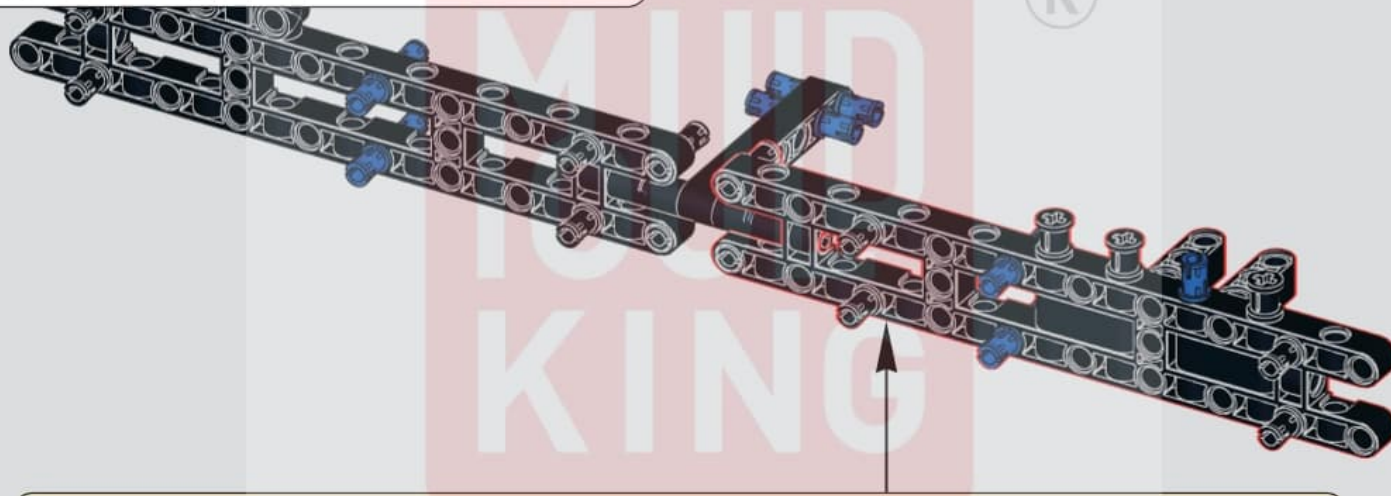



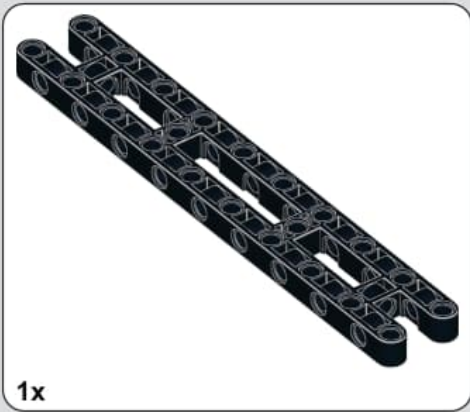

330

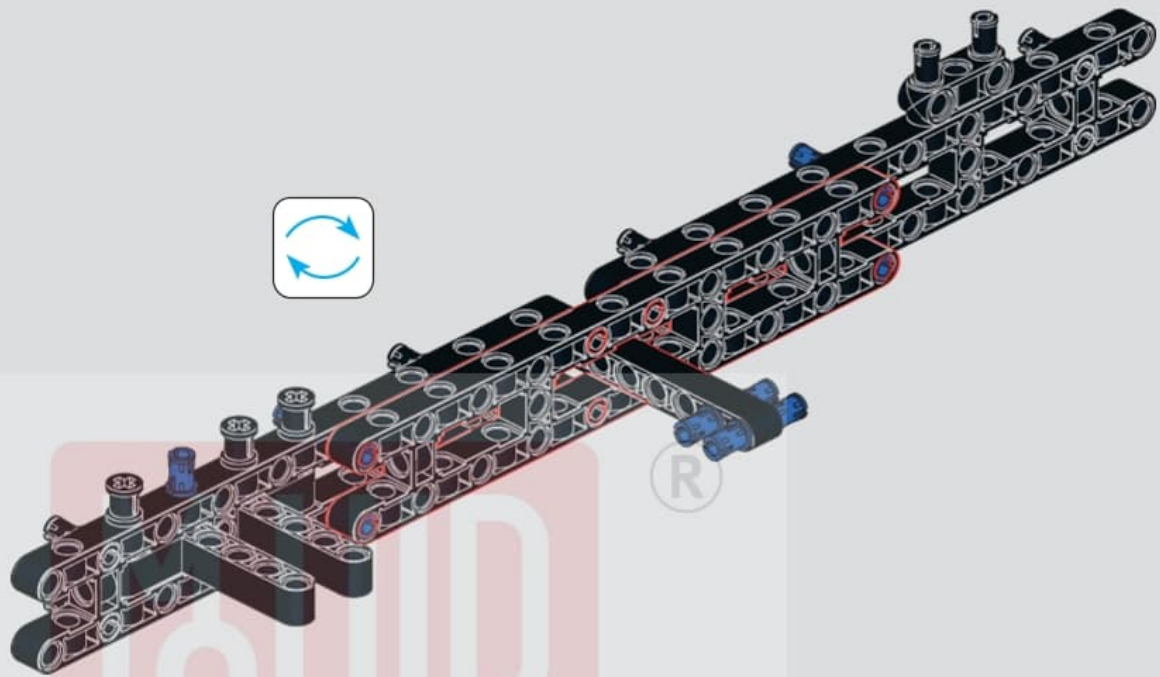

331

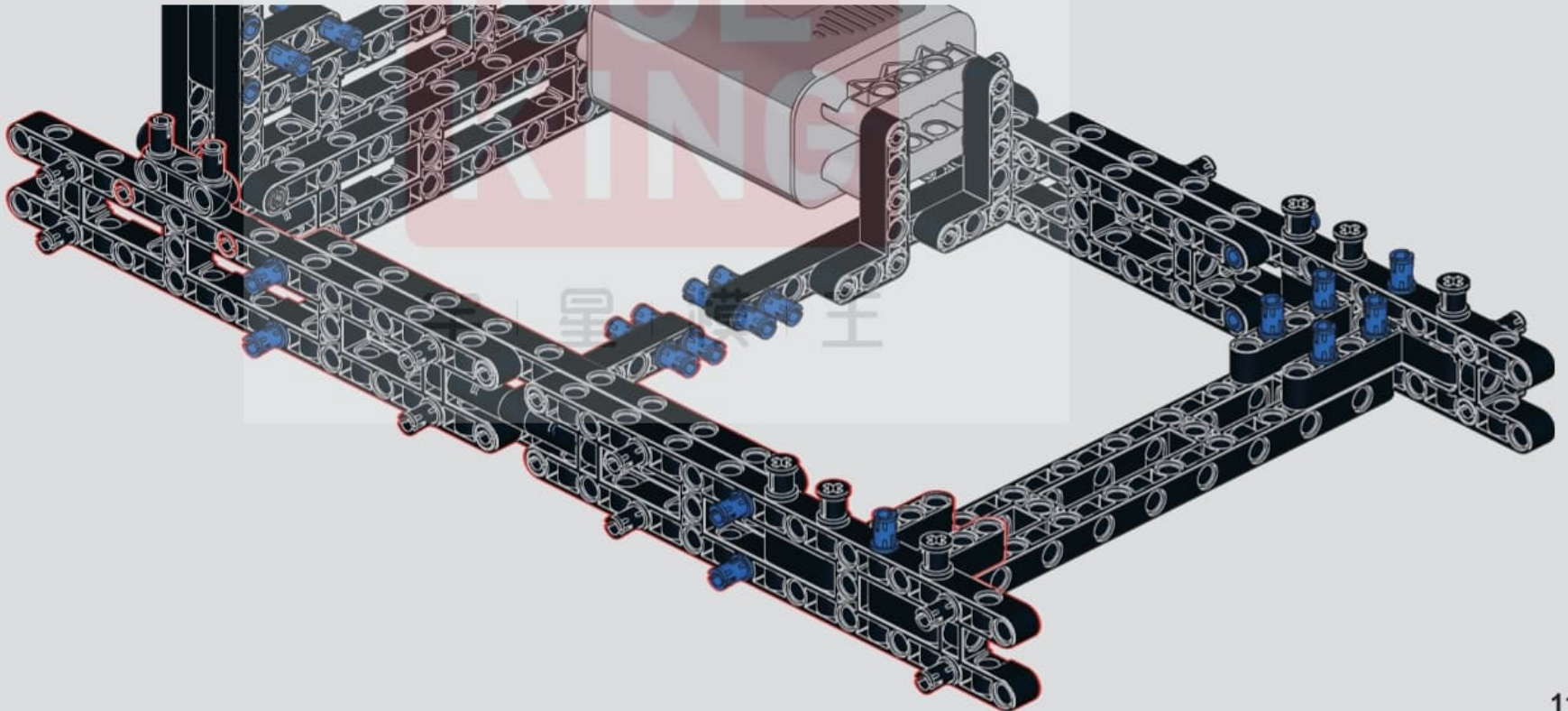





332

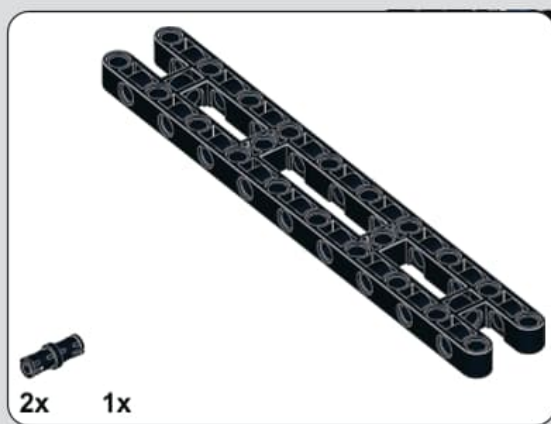
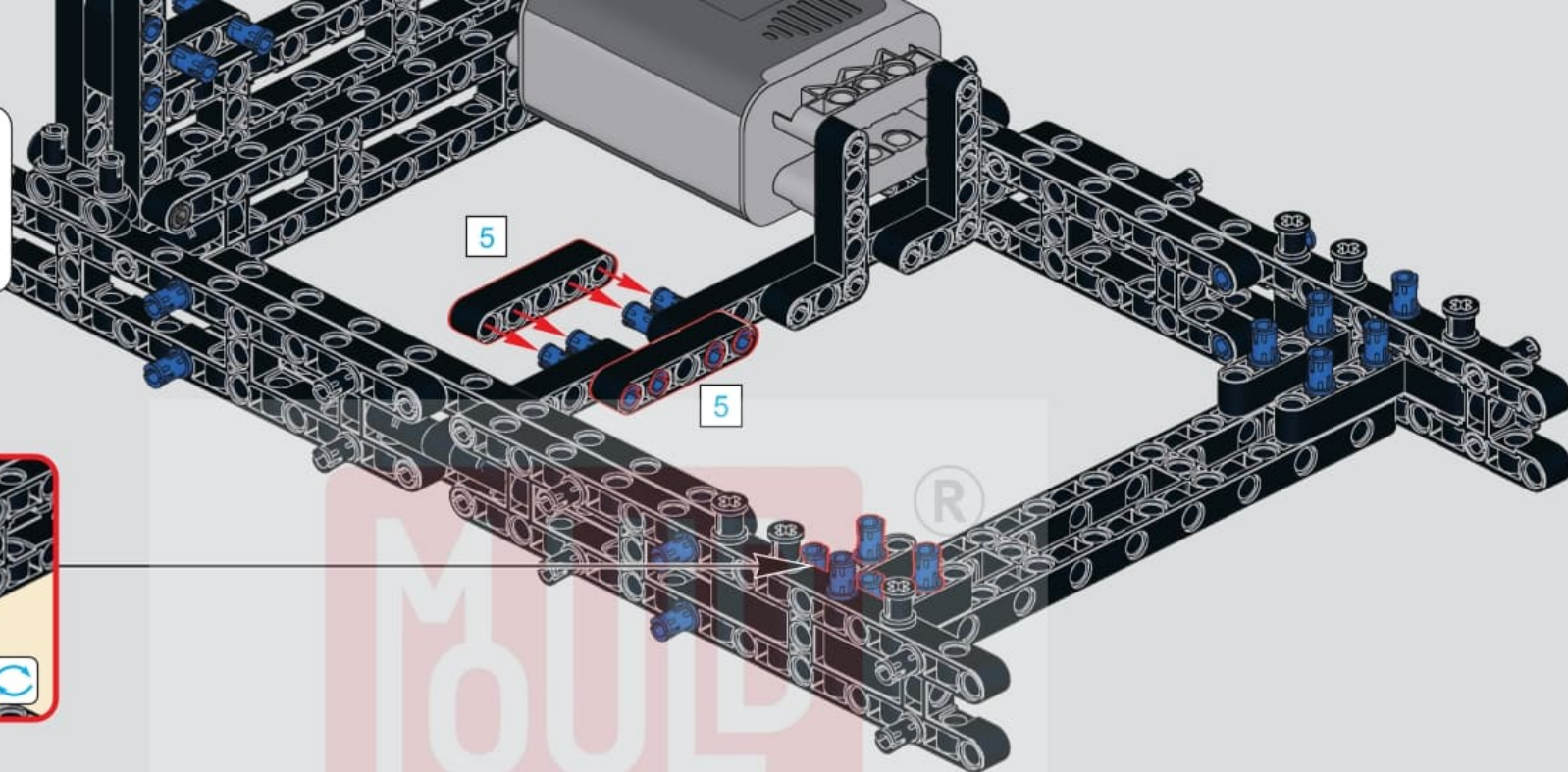
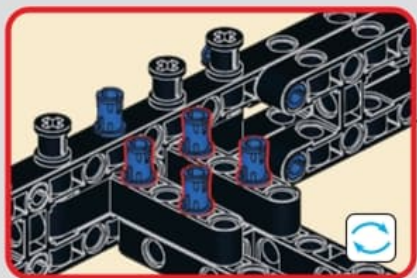

333

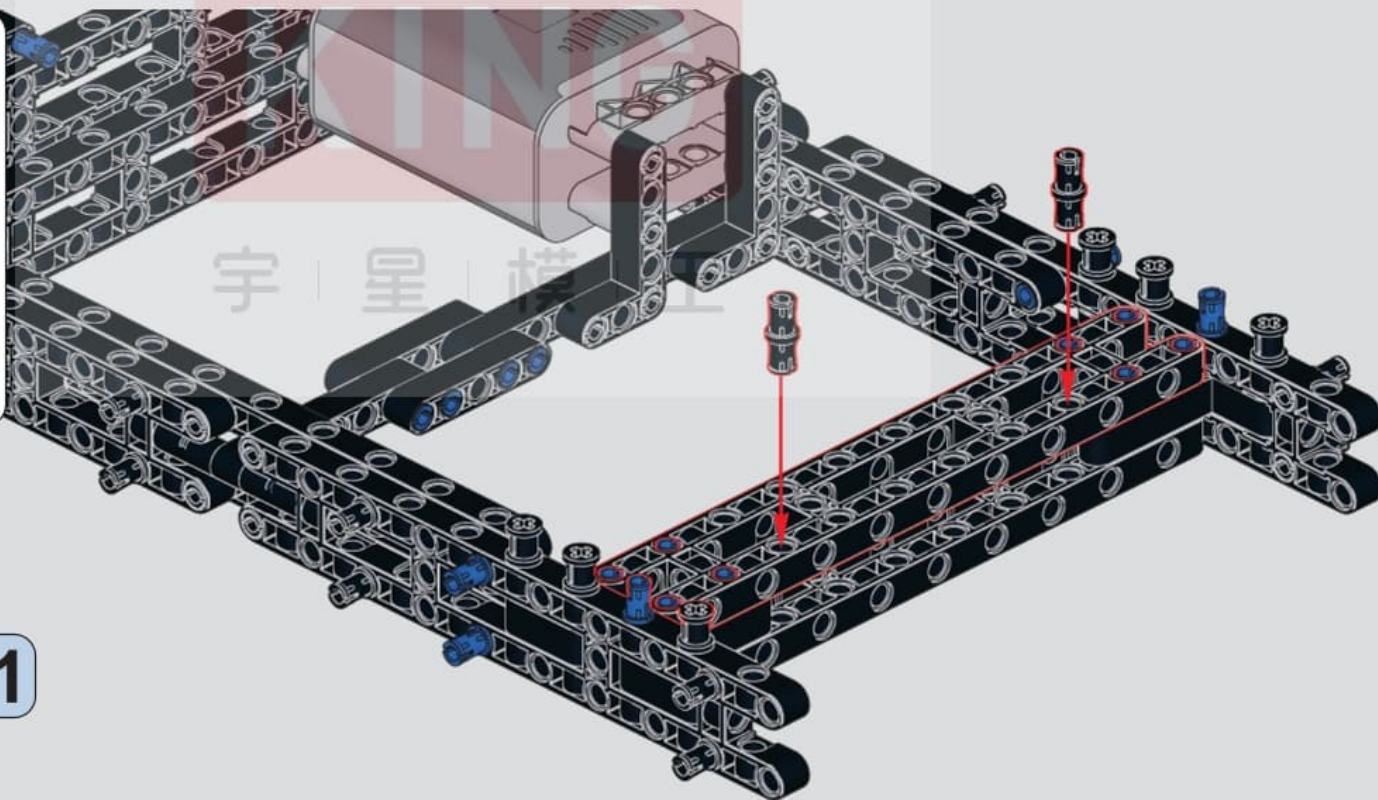





334

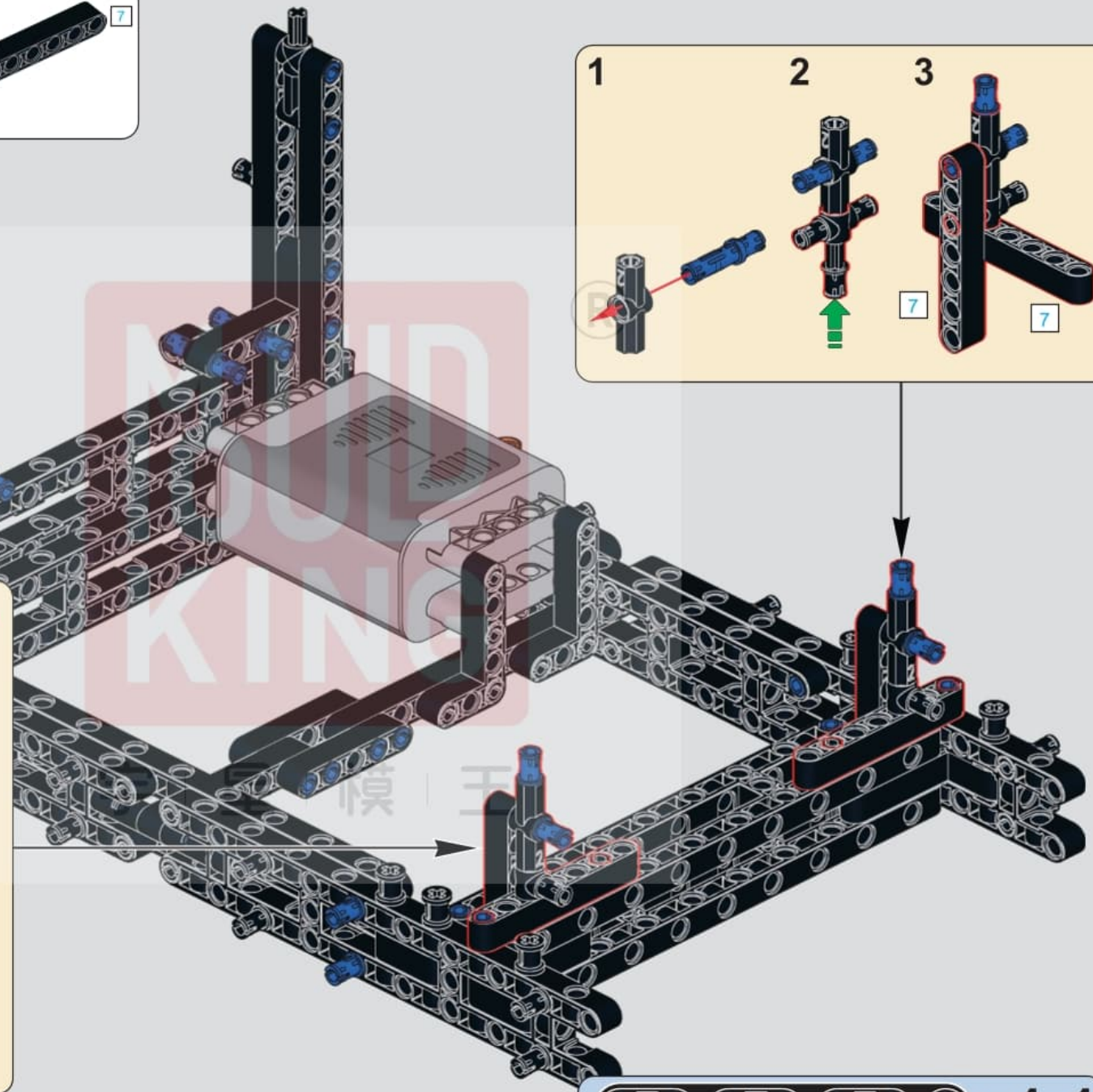
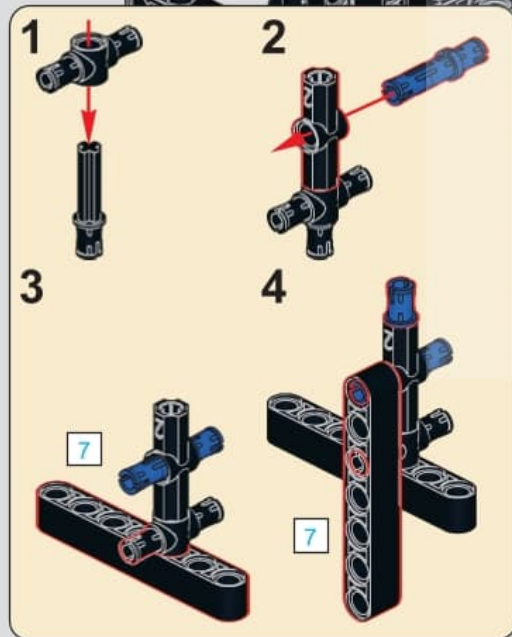
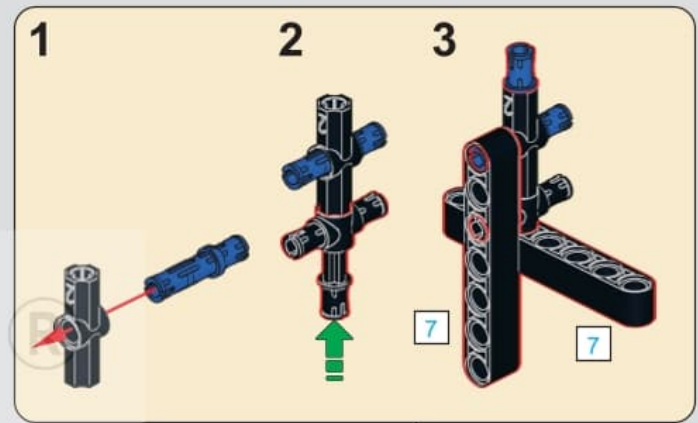

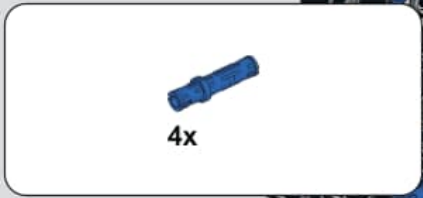

335

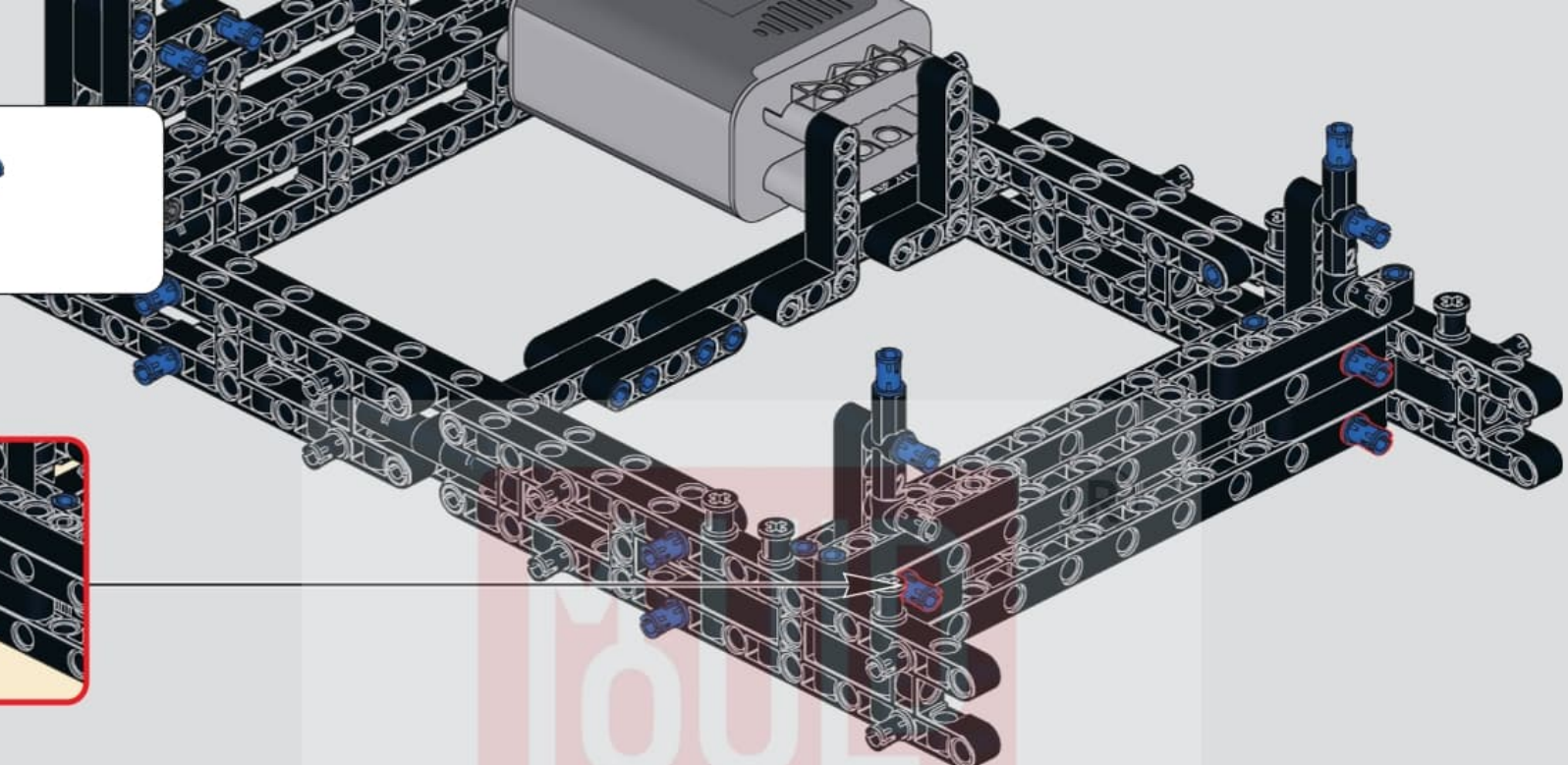

336

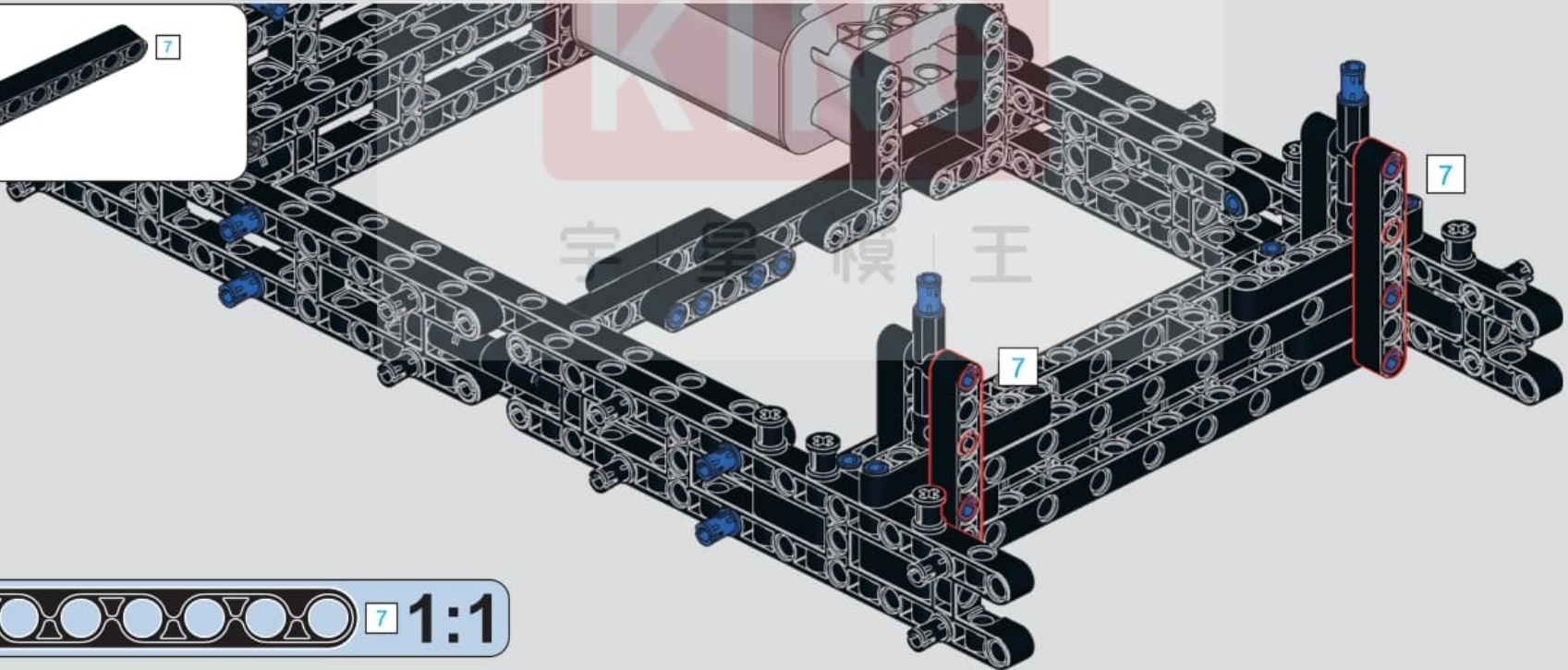



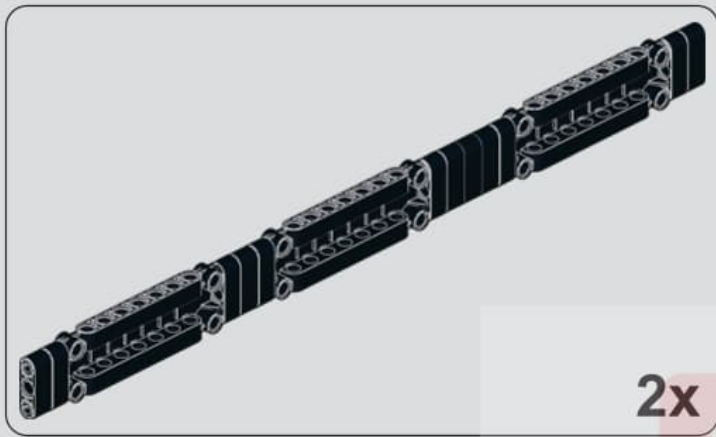

337

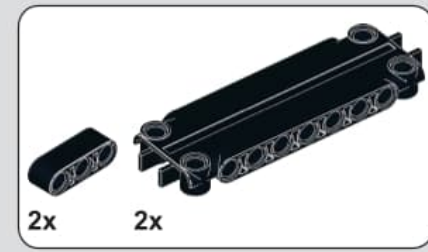

338

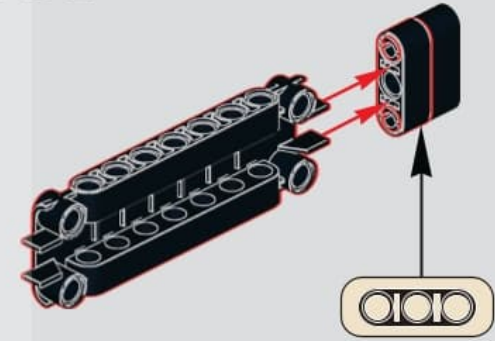
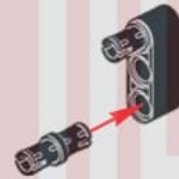

339

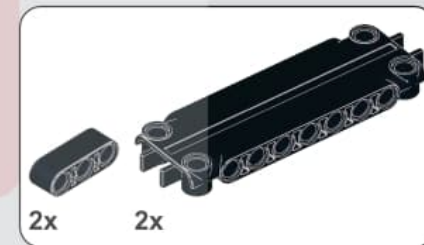
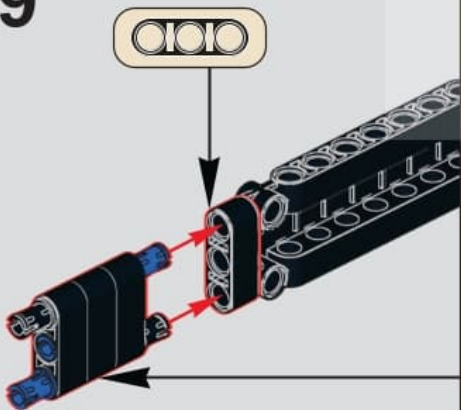

340

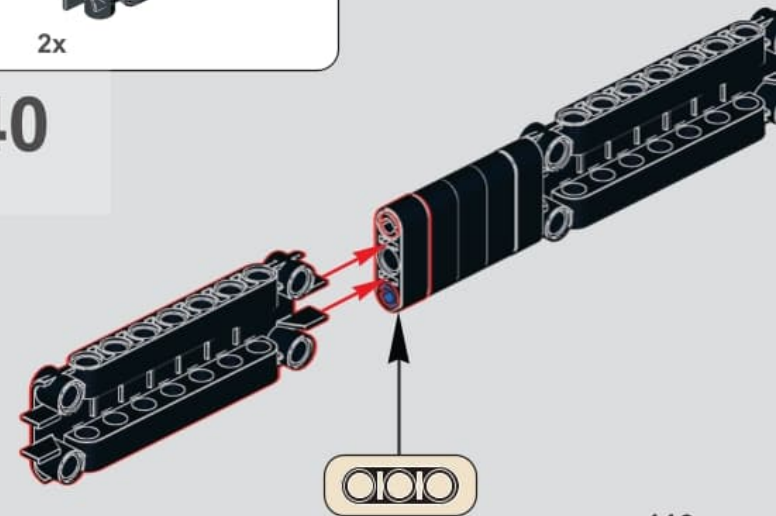

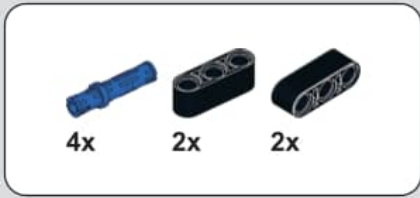

341

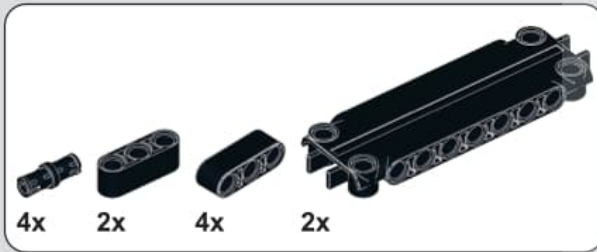

342

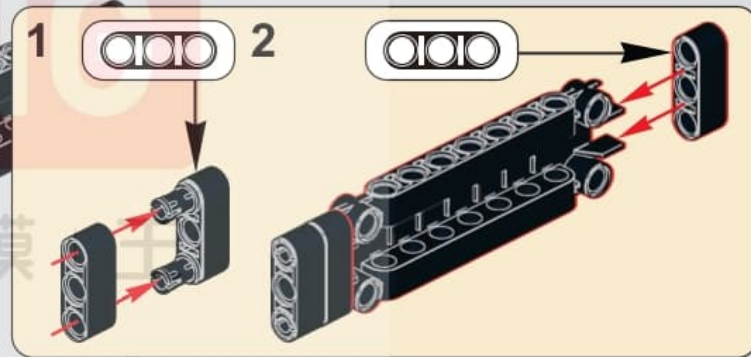
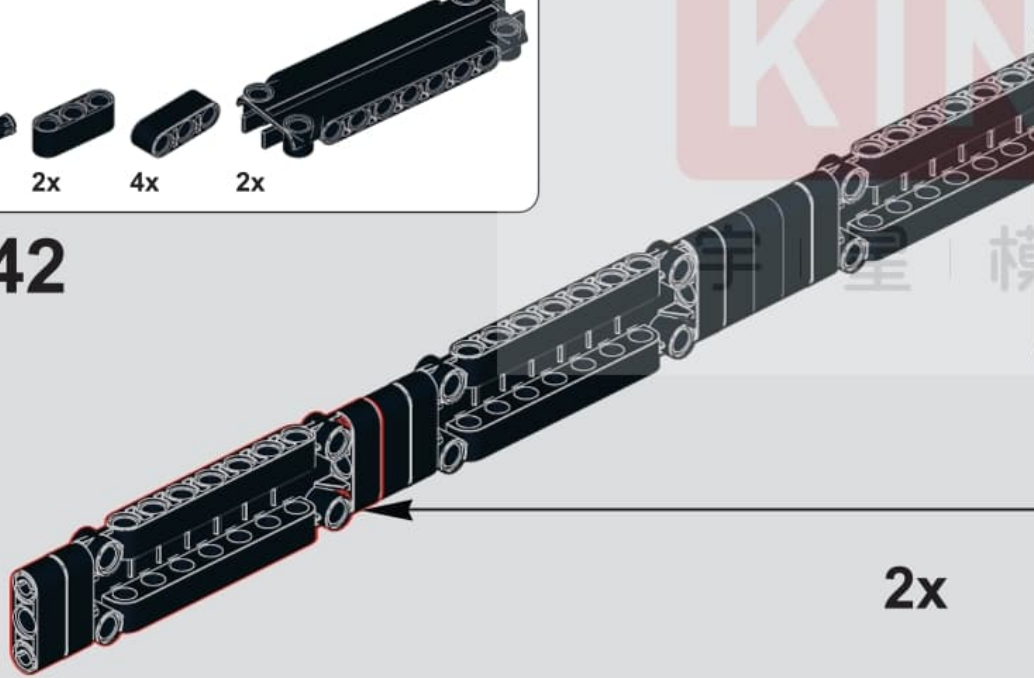

2x



343

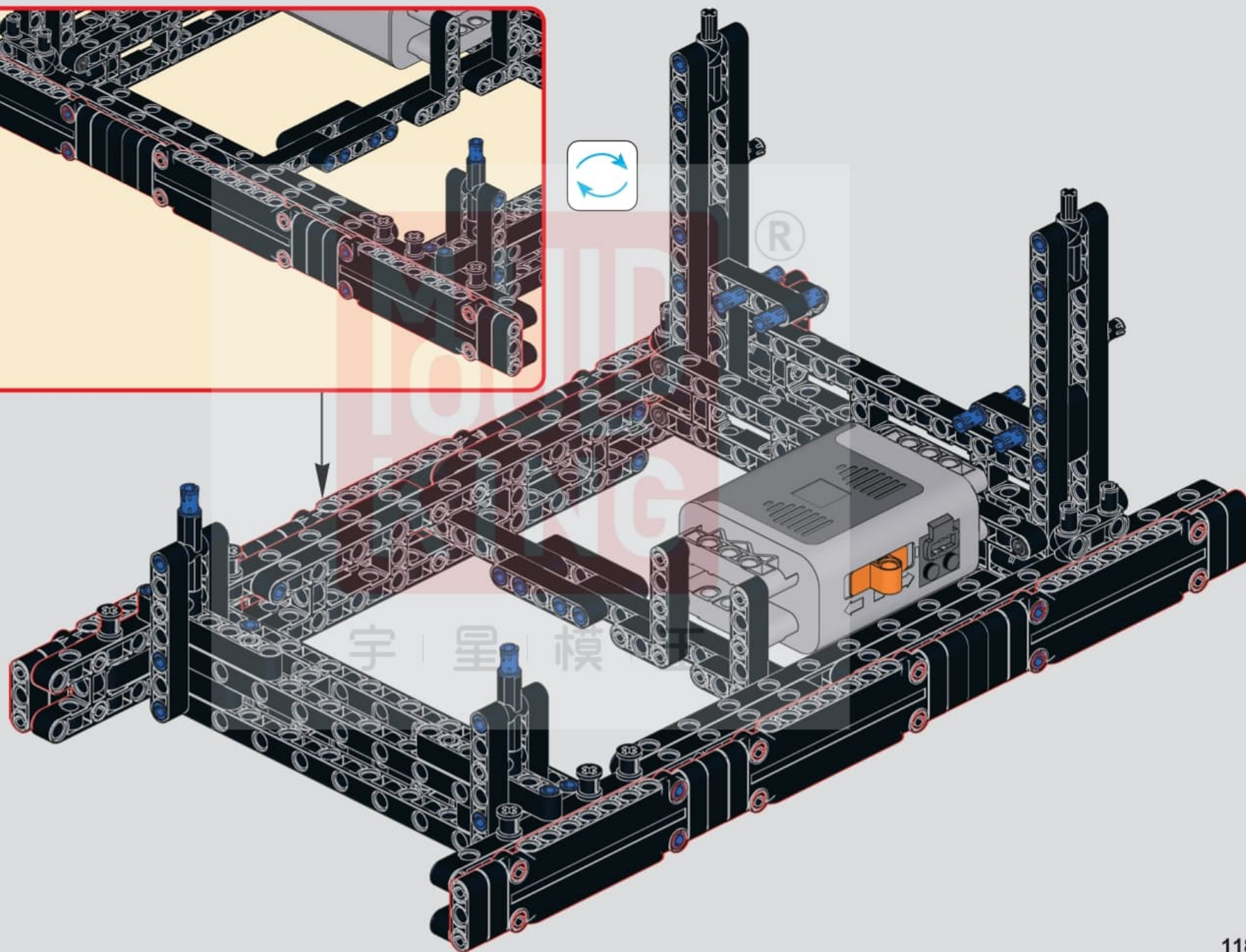
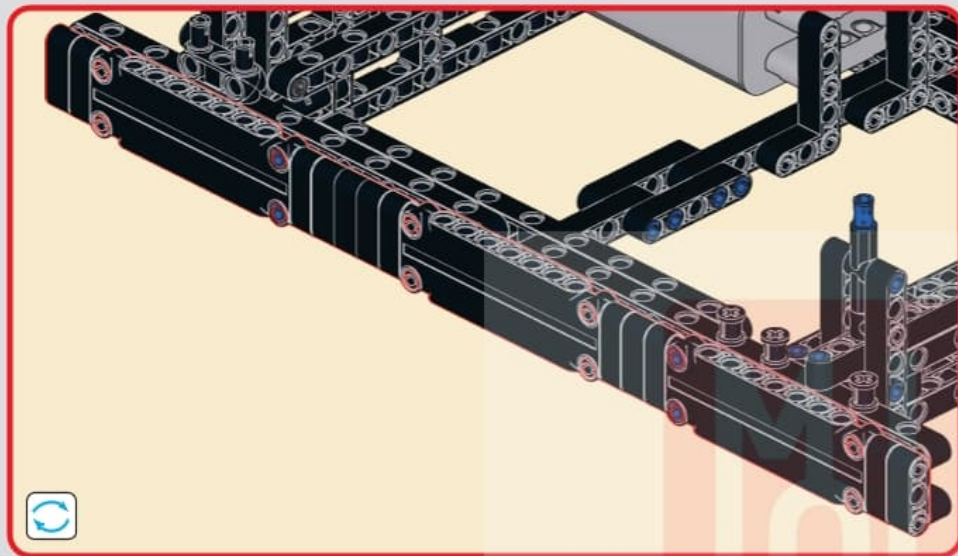



344

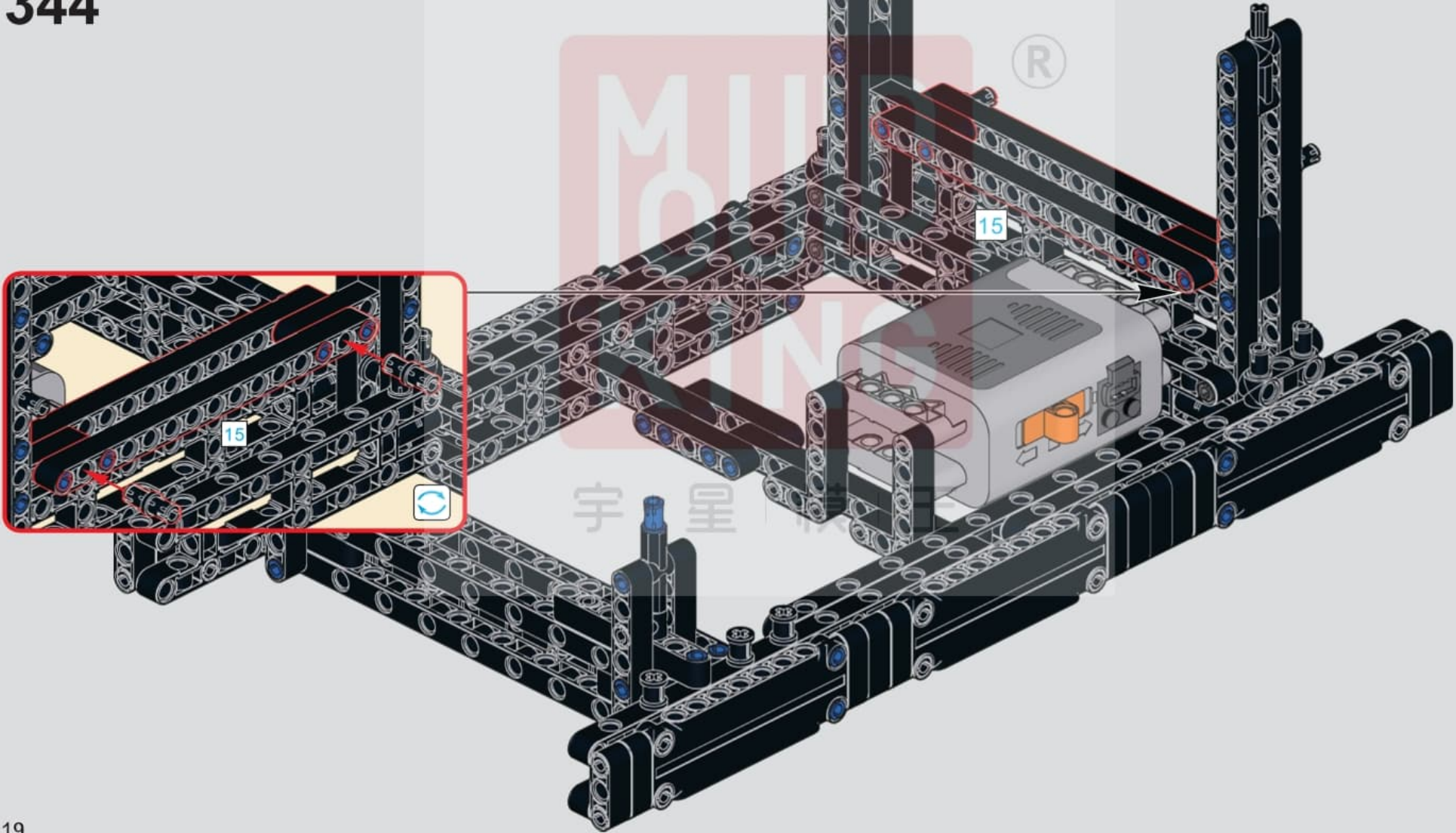



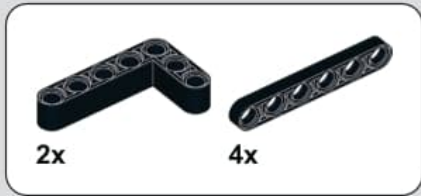

345

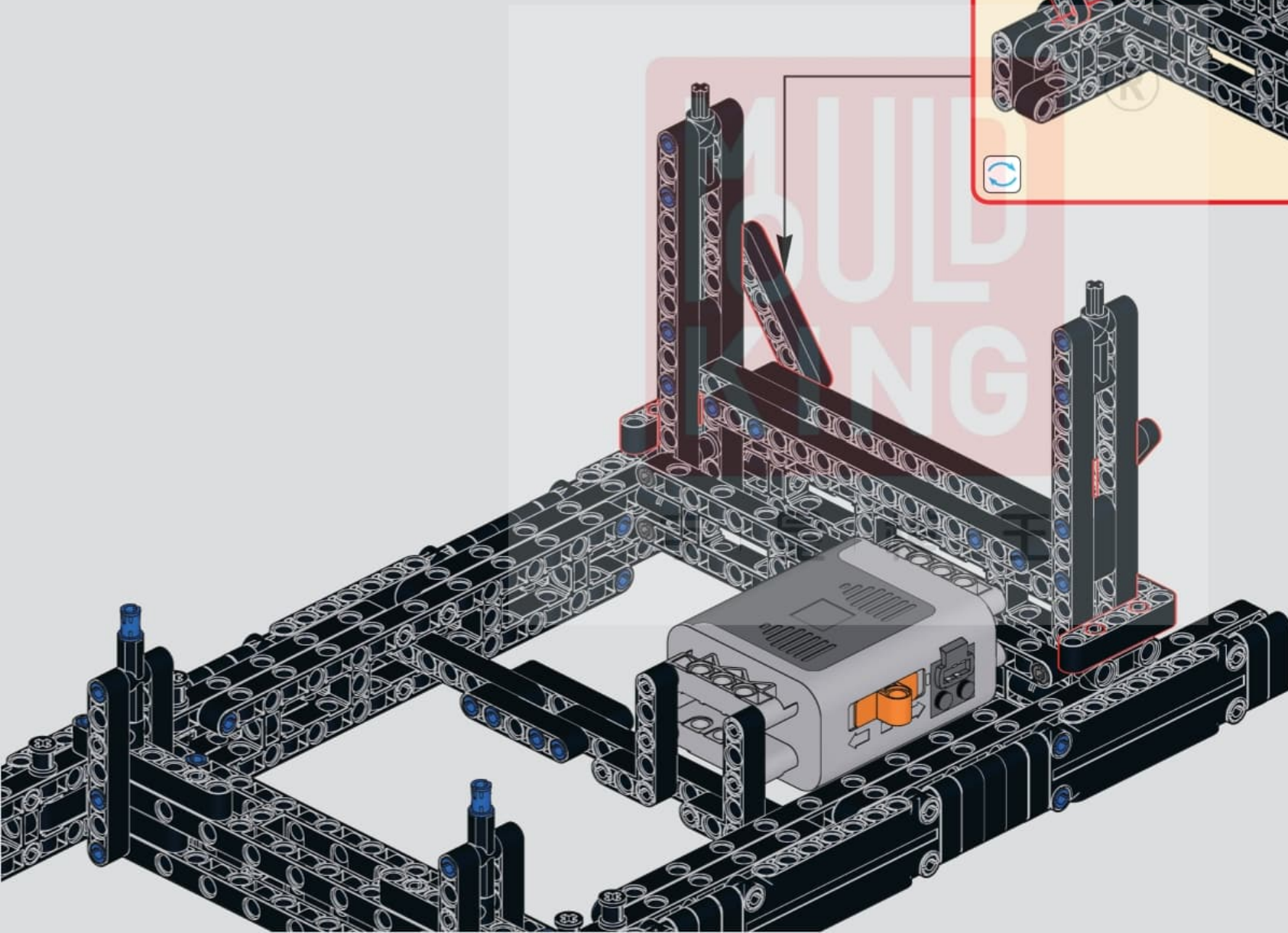
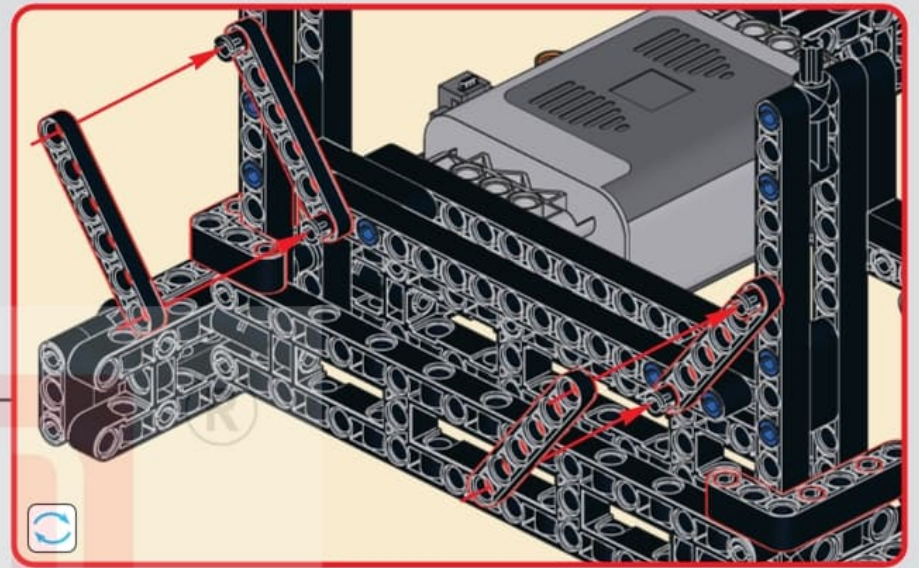



346

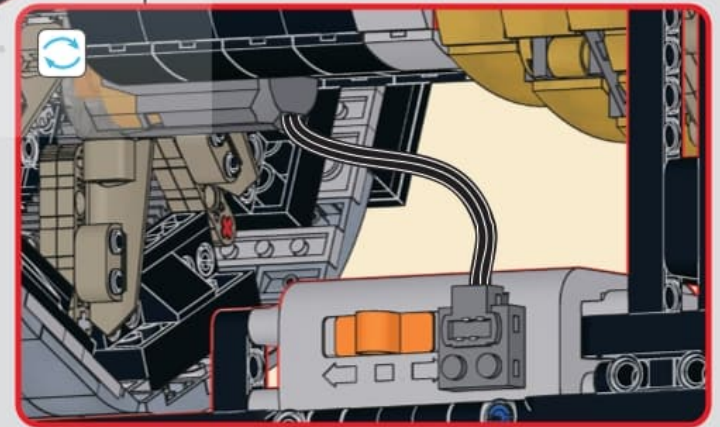
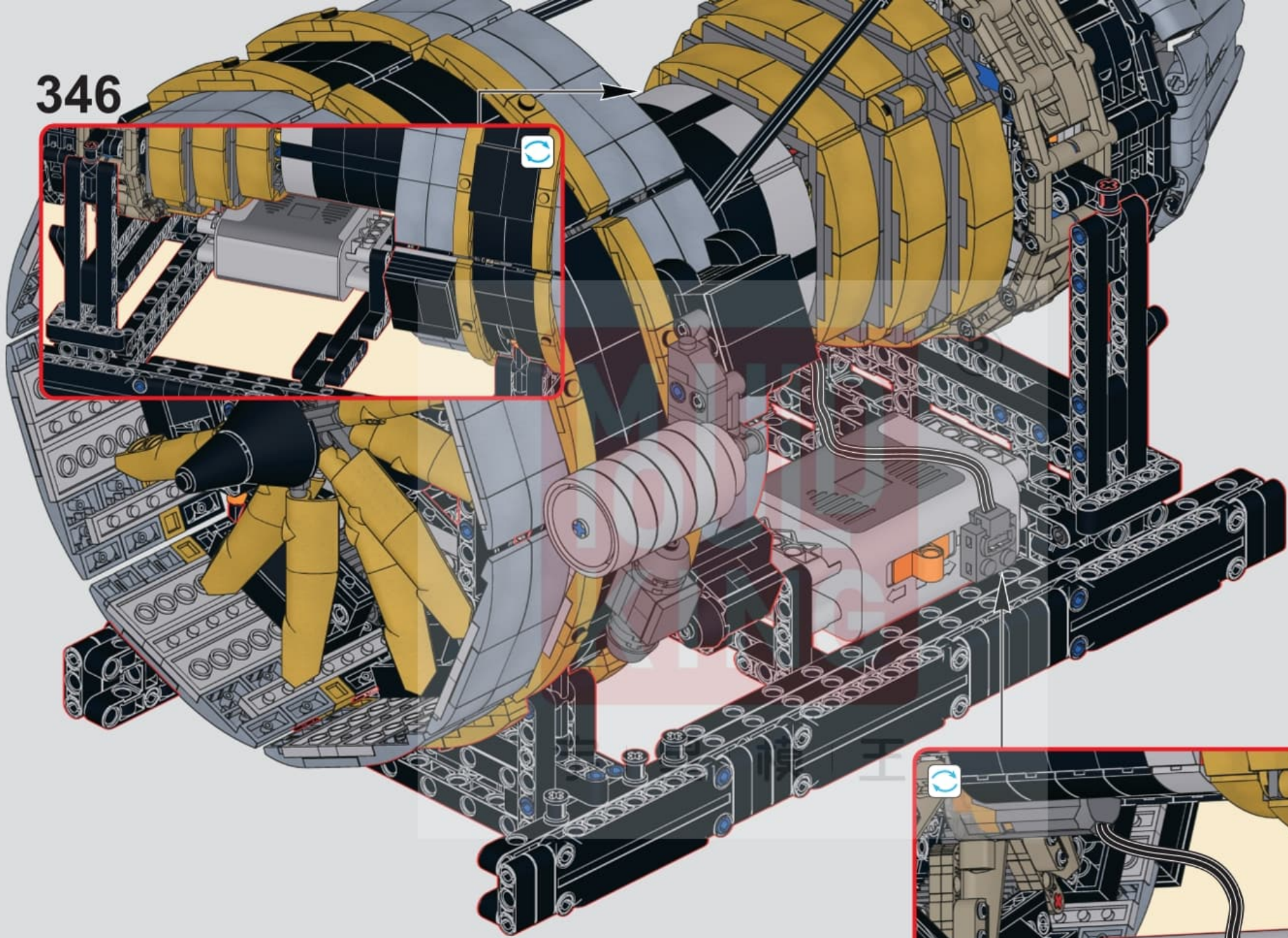



347

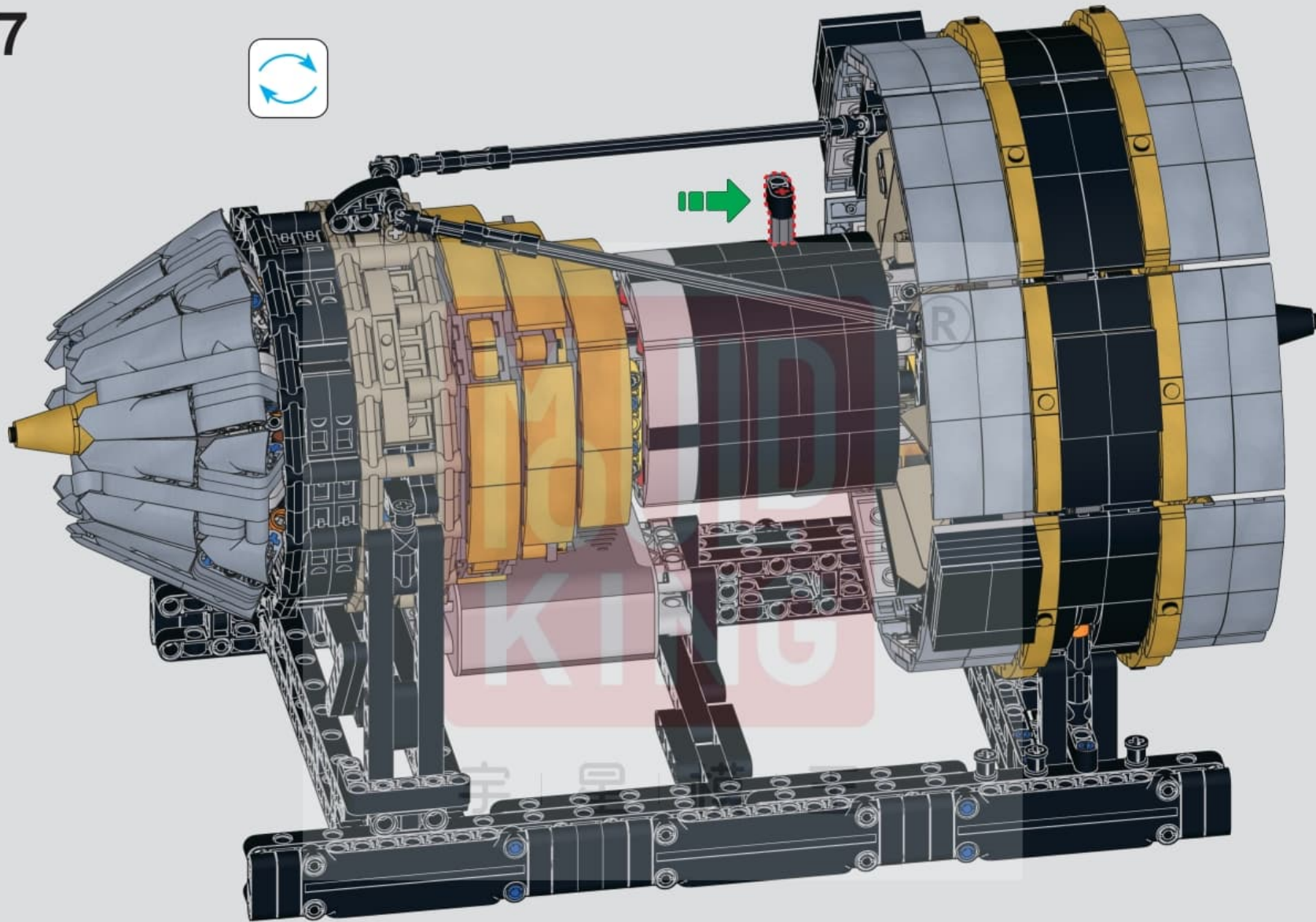

旋转轴柱,可控制扇翼旋转的速度,当前状态为空挡。

Rotate the axle bolt to control the speed of the propeller rotation; the current setting is neutral.

Drehen Sie den Achsbolzen, um die Geschwindigkeit der Propellerrotation zu steuern; die aktuelle Einstellung ist neutral.

Tournez le boulon de l'axe pour contrôler la vitesse de rotation de l'hélice ; le réglage actuel est en point mort.

Ruota il bullone dell'asse per controllare la velocità di rotazione dell'elica; l'impostazione corrente è in folle.

Gire el perno del eje para controlar la velocidad de rotación de la hélice; la configuración actual está en punto muerto.

軸ボルトを回してプロペラの回転速度を制御します。現在の設定はニュートラルです。



348

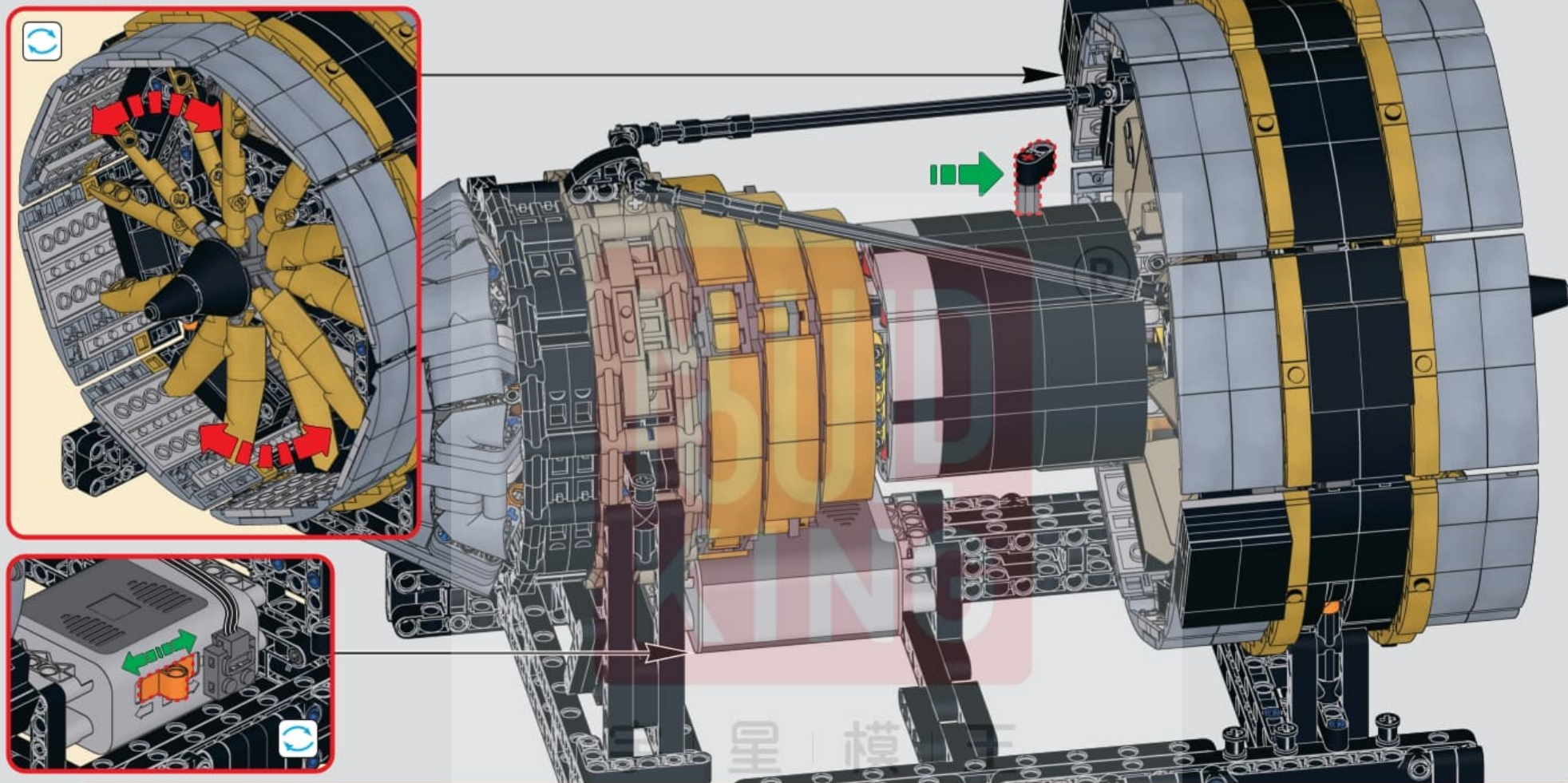

橙色按钮向左推动, 如图所示旋转轴栓, 调整扇翼旋转速度为1挡, 扇翼逆时针旋转; 橙色按钮向右推动, 扇翼顺时针旋转。

Push the orange button to the left to rotate the axle bolt as shown, setting the fan blade rotation speed to level 1, causing it to rotate counterclockwise; pushing the orange button to the right makes the fan blades rotate clockwise.

Drücken Sie den orangefarbenen Knopf nach links, um die Achsschraube wie gezeigt zu drehen und die Drehgeschwindigkeit der Flügel auf Stufe 1 einzustellen, was sie gegen den Uhrzeigersinn dreht; das Drücken des orangefarbenen Knopfes nach rechts bewirkt, dass sich die Flügel im Uhrzeigersinn drehen.

Poussez le bouton orange vers la gauche pour faire tourner le boulon de l'axe comme indiqué, réglant la vitesse de rotation des pales du ventilateur sur le niveau 1, les faisant tourner dans le sens antihoraire; pousser le bouton orange vers la droite fait tourner les pales dans le sens horaire.

Spingere il pulsante arancione verso sinistra per ruotare il bullone dell'asse come mostrato, impostando la velocità di rotazione delle pale del ventilatore al livello 1, facendole girare in senso antiorario; spingendo il pulsante arancione verso destra le pale girano in senso orario.

Empuje el botón naranja hacia la izquierda para girar el perno del eje como se muestra, ajustando la velocidad de rotación de las aspas del ventilador al nivel 1, lo que las hace girar en sentido antihorario; empujar el botón naranja hacia la derecha hace que las aspas giren en sentido horario.

オレンジ色のボタンを左に押し、図のように軸ボルトを回転させ、ファンブレードの回転速度をレベル1に設定し、反時計回りに回転させます。オレンジ色のボタンを右に押し、ファンブレードが時計回りに回転します。



349

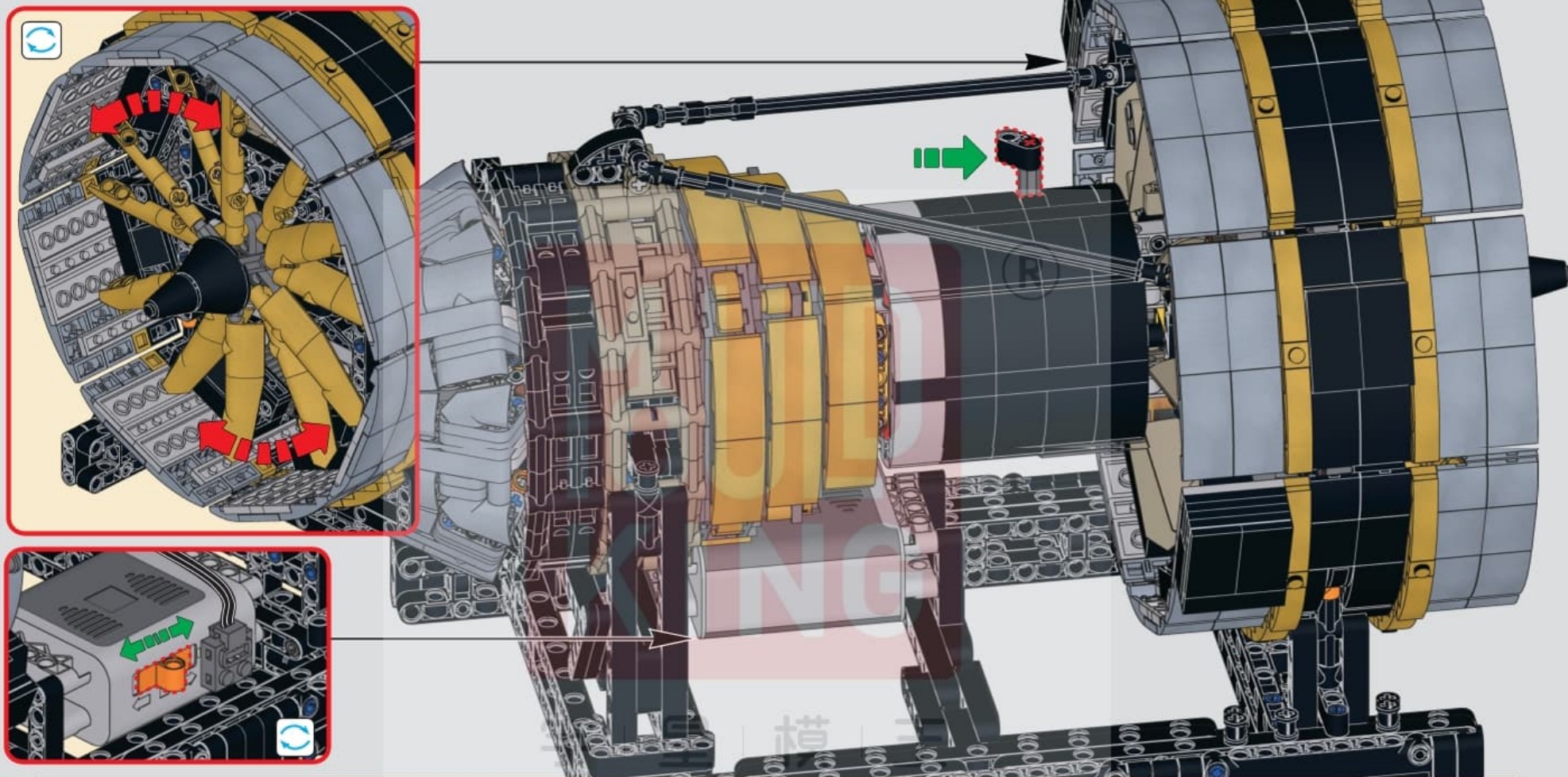

橙色按钮向左推动, 如图所示旋转轴栓, 调整扇翼旋转速度为2挡, 扇翼逆时针旋转; 橙色按钮向右推动, 扇翼顺时针旋转。

Push the orange button to the left to rotate the axle bolt as shown in the diagram, setting the fan blade rotation speed to level 2, causing it to rotate counterclockwise; pushing the orange button to the right makes the fan blades rotate clockwise.

Drücken Sie den orangefarbenen Knopf nach links, um die Achsschraube wie im Diagramm gezeigt zu drehen und die Drehgeschwindigkeit der Flügel auf Stufe 2 einzustellen, was sie gegen den Uhrzeigersinn dreht; das Drücken des orangefarbenen Knopfes nach rechts bewirkt, dass sich die Flügel im Uhrzeigersinn drehen.

Poussez le bouton orange vers la gauche pour faire tourner le boulon de l'axe comme indiqué sur le diagramme, réglant la vitesse de rotation des pales du ventilateur sur le niveau 2, les faisant tourner dans le sens antihoraire; pousser le bouton orange vers la droite fait tourner les pales dans le sens horaire.

Spingere il pulsante arancione verso sinistra per ruotare il bullone dell'asse come mostrato nel diagramma, impostando la velocità di rotazione delle pale del ventilatore al livello 2, facendole girare in senso antiorario; spingendo il pulsante arancione verso destra le pale girano in senso orario.

Empuje el botón naranja hacia la izquierda para girar el perno del eje como se muestra en el diagrama, ajustando la velocidad de rotación de las aspas del ventilador al nivel 2, lo que las hace girar en sentido antihorario; empujar el botón naranja hacia la derecha hace que las aspas giren en sentido horario.

オレンジ色のボタンを左に押し、図のように軸ボルトを回転させ、ファンブレードの回転速度をレベル2に設定し、反時計回りに回転させます。オレンジ色のボタンを右に押し、ファンブレードが時計回りに回転します。



350

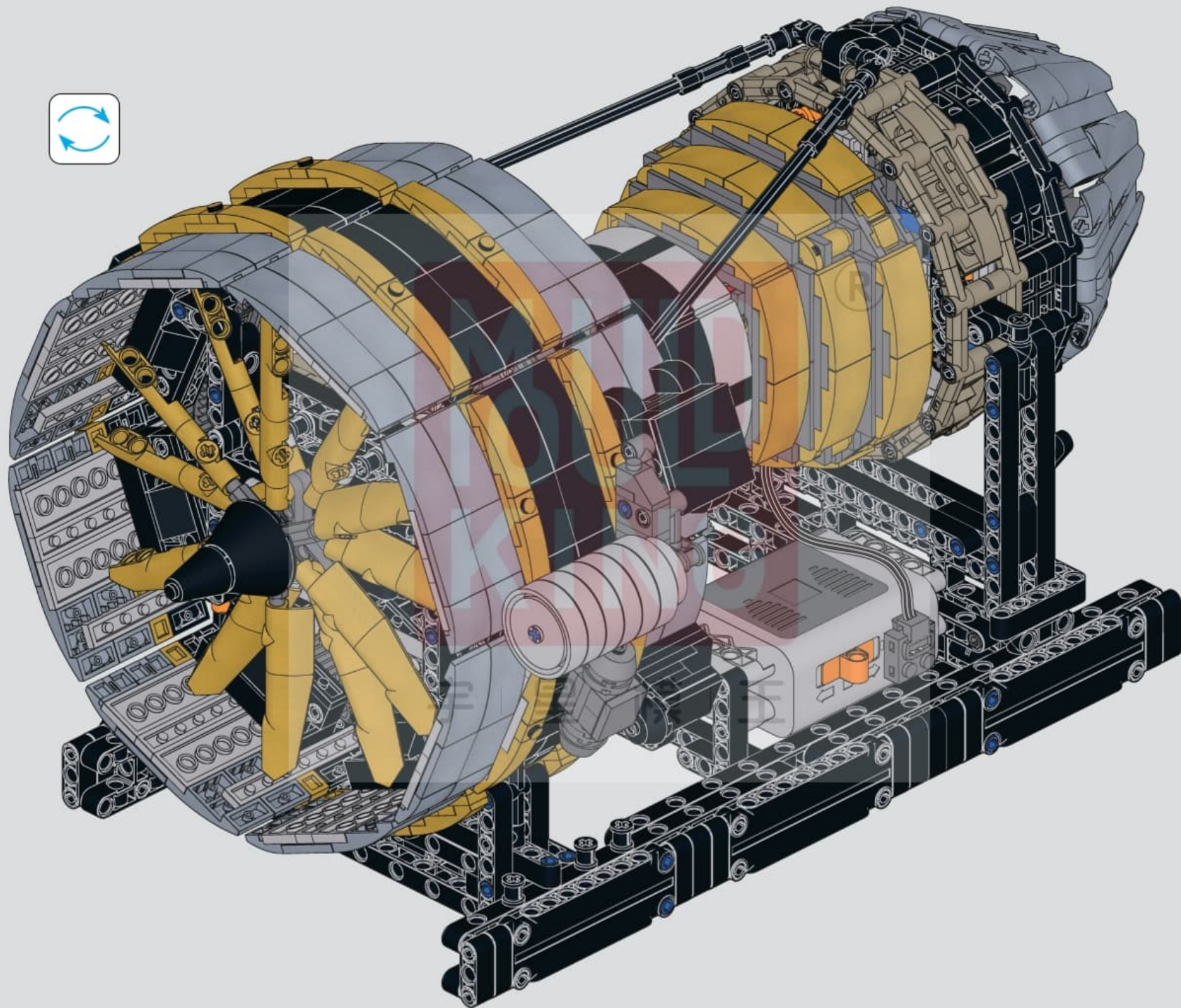



351

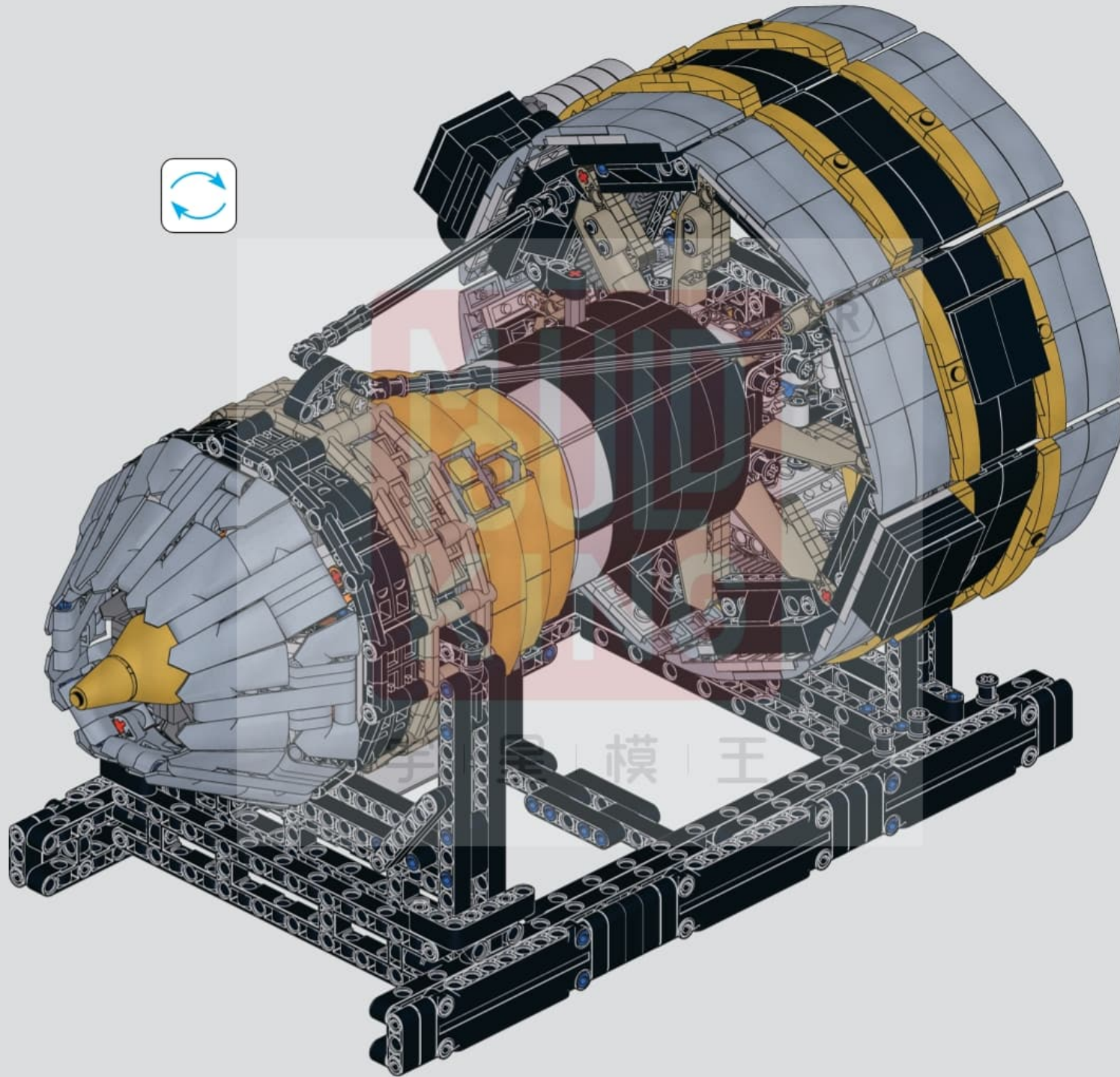

**MOULD  
KING**®

宇 | 星 | 模 | 王

